

April, 2024

Volume 1, Issue 1



№ 001

Management and Future Technologies

SCIENTIFIC JOURNAL

journal.umft.uz

Jurnal sohalari: menejment, dasturiy injiniring, sun'iy intellekt texnologiyalari, kompyuter injiniringi, infokommunikatsiya injiniringi, axborot xavfsizligi, raqamli iqtisodiyot, pedagogika va psixologiya, matematika va fizika

Tahririyat kengashi raisi

t.f.d., prof. O'tkir Xamdamov
"University of Management and Future Technologies" universiteti rektori

Bosh muharrir

t.f.f.d. dot. Muhriddin Muxiddinov
"University of Management and Future Technologies" universiteti Ilmiy va uslubiy ishlar bo'yicha prorektori

Tahririyat kengashi a'zolari

t.f.d., prof. Xakim Zaynidinov
t.f.d., prof. Muxammadjon Musayev
t.f.d., prof. Shavkat Fozilov
f-m.f.d. prof. Aripov Mersaid
f-m.f.d. prof. Alov Raxmatillo
t.f.d., prof. Marat Raxmatullayev
t.f.d., prof. Dilnoz Muxamediyeva
i.f.d., prof. Toxir Hasanov
i.f.d., prof. To'lqin Boboqulov
t.f.d., prof. Jamshid Sultonov
f-m.f.d. prof. Dildora Muhamediyeva
i.f.d., prof. Sherzod Rajabov
p.f.d., prof. Qurboniyoz Panjiyev
p.f.d., prof. Muhabbat Hakimova
t.f.d., prof. Nargiza Usmanova
p.f.d., prof. Nishonboy Kiyamov
p.f.d., prof. Qutlug'bek Qodirov
t.f.d., dot. Halimjon Xujamatov
t.f.d., dot. Ibragim Atadjanov

Muharrirlar

Farhod Ahmedov (J. Koreya)
Sherzod Mustafaqulov (O'zbekiston)
Akmalbek Abdusalomov (J. Koreya)
Bahtiyor Akmuradov (O'zbekiston)
Sherzod Abdullayev (O'zbekiston)
Shabir Ahmad (J. Koreya)
Dilshod Rahmatov (Germaniya)
O.A. Hidayov (Germaniya)
Akmaljon Abdullayev (O'zbekiston)
Jinsoo Cho (J. Koreya)
Jamshid Elov (O'zbekiston)
Young Im Cho (J. Koreya)
Fazliddin Maxmudov (J. Koreya)
Alpamis Kutlimuratov (O'zbekiston)
Faheem Khan (J. Koreya)
Lilia Tightiz (J. Koreya)
Shahnoza Sultanova (O'zbekiston)
Safiullah Khan (Buyuk Britaniya)
Seytkamal Medetov (Fransiya)
Avaz Qaxxorov (O'zbekiston)
Doston Xasanov (O'zbekiston)
Sabina Umirzakova (J. Koreya)
Elmurod Urinov (O'zbekiston)
Muhriddin Umarov (O'zbekiston)
Urmanov Odil (J. Koreya)
Sobir Radjabov (O'zbekiston)

Dizayner

Eshmetov Daler

MUNDARIJA

TEXNIKA FANLARI

6 OLIY TA'LIMNI BOSHQARISH VA MONITORINGINI YURITISH JARAYONLARINI RAQAMLASHTIRISH MASALASI VA ISTIQBOLLARI

Utkir Xamdamov, Alisher Abdullaev, Xurshid Sultonov, Shaxrizoda Raxmatillaeva

12 THE ROLE AND PROSPECTS OF DIGITAL AND INNOVATIVE TECHNOLOGIES IN EDUCATION FOR THE VIZUALLY IMPAIRED PEOPLE

Mukhriddin Mukhiddinov, Oybek Djuraev, Jasurbek Djuraev, Shakhrizoda Rakhmatillaeva

17 VIDEOMONITORING HOSSALARIGA ASOSLANGAN MASOFAVIY TA'LIM JARAYONLARINI TAKOMILLASHTIRISHNING AXBOROT MODELI

Sirojiddin Xalilov, Farangiza Omonullaeva, Maftuna Mannapova

23 ELEKTRON SO'ZLARNI VEKTORLI IFODALASH TEXNOLOGIYASI

Baxtiyor Akmuradov

28 A COMPARATIVE ANALYSIS OF TRADITIONAL AND DEEP LEARNING-BASED APPROACHES FOR FACE DETECTION: PERFORMANCE, ADVANCEMENTS, AND CHALLENGES

Elmurod Urinov, Nurbek Kholmurodov

32 O'ZBEKCHA MATNDAN NUTQ SIZTEZLASH DASTURIY TIZIMI UCHUN DIFONLAR BAZASINING QURILISHI

Farrux Axmedov, Muhridin Umarov

37 NUTQNI TANIB OLISHNI AMALGA OSHIRISH BOSQICHLARI

O'rinboy Naziraliyev

43 INFOKOMMUNIKATSIYA TARMOQLARDA BUYURTMALARNI TUSHISH VA
ULARGA XIZMAT KO'RSATISH JARAYONLARINI MODELLASHTIRISH

A.F.Izbasarov, Z.Z. Nigmatov, A.A.Yaxyoyev

IJTIMOIIY FANLAR

50 BLOKCHEYN TEXNOLOGIYASINING QO`LLANILISHI VA NAZARIY JIHATLARI

Sherzod Abduraimov

59 JAHON IQTISODIYOTINING RAQAMLI TRANSFORMATSIYASI:
TENDENSIYALAR VA ISTIQBOLLARI

Djangirova Umida Abdugaliyevna

65 THE APPLICATION OF DIGITAL MARKETING STRATEGIES

Abdulakhatov Muzaffarjon

74 THE EFFECTS OF DIGITAL MARKETING ON A COMPANY'S OVERALL
COMMERCIAL GROWTH IN UZBEKISTAN

Dadabayeva Ra'no

82 THE ROLE AND IMPORTANCE OF THE DIGITAL ECONOMY IN THE LABOR
MARKET

Ulugbek Narmanov, Guzal Abdishukurov

88 RAQAMLI IQTISODIYOTNI RIVOJLANTIRISHNING XORIJIY TAJRIBALARI

Lutfiy Farangiz Sharidin qizi, Ismoilova Mohigul Yusubjon qizi.

95 OLIY HARBIY TA'LIM MUASSASALARIDA RAQAMLI PEDAGOGIKANING
O'RNI VA AHAMIYATI

Izbasarov A.F., Abdurayimov S.S., Nigmatov Z.Z.

**101 BO'LAJAK MUHANDIS-PEDAGOGLARNI LOYIHALASH
KOMPETENSIYALARINI KOMPYUTER GRAFIKASI VOSITASIDA
RIVOJLANTIRISH MODELI**

Kayumova Kamola, Dilshod Mansurov

**107 MASOFAVIY TA'LIM OLUVCHILAR FAOLIYATINI INTEGRALLASHGAN
MONITORINGINI OLIB BORISH KO'RSATKICHLARI**

Odil Asqaraliyev, Dilshod Mansurov, Kayumova Kamola

MATEMATIKA VA FIZIKA FANLARI

**114 FIZIKANI O'QITISHDA "PhET – INTERACTIVE SIMULATIONS" DASTURIDAN
FOYDALANISH**

Asror Ulashov, Umida Naziraliyeva, Rahmatillayeva Shahrizoda

121 TERMoeLEKTRIK HODISALAR AFZALLIK VA KAMCHILIKLARINI O'RGANISH

Umida Naziraliyeva, Asror Ulashov

**128 FIZIKA DARSLARIDA ZAMONAVIY TEXNOLOGIYALARDAN FOYDALANIB
TALABALAR BILIMLARINI BAHOLASH**

Ya.A. Axmedov, X.N. Karimov

**136 HISOB (MATEMATIKA) FANINI O'RGANISHDA ONLINE TIZIMLARNING
IMKONIYATLARI**

Quvonchbek Asadov, Xonxo'jayev Lazizxon



Mualliflar

Utkir Xamdamov

Kommunikatsiya va raqamli texnologiyalar kafedrası, "University of management and future technologies" universiteti, Toshkent, 100208, O'zbekiston;
utkir.hamdamov@mail.ru

Alisher Abdullaev

Oliy ta'lim, fan va innovatsiyalar vazirligi, Toshkent, O'zbekiston;
ali1914@gmail.com

Xurshid Sulonov

Oliy ta'lim, fan va innovatsiyalar vazirligi, Toshkent, O'zbekiston;

Shaxrizoda Raxmatillaeva

Kommunikatsiya va raqamli texnologiyalar kafedrası, "University of management and future technologies" universiteti, Toshkent, 100208, O'zbekiston;

Mas'ul: utkir.hamdamov@mail.ru

OLIIY TA'LIMNI BOSHQARISH VA MONITORINGINI YURITISH JARAYONLARINI RAQAMLASHTIRISH MASALASI VA ISTIQBOLLARI

Annotatsiya: Maqola oliy ta'lim muassasalari faoliyatini raqamlashtirish orqali oliy ta'lim jarayonlarini modellashtirish, boshqarish va axborot tizimini ishlab chiqish hamda joriy etish masalalariga bag'ishlangan. Maqolada oliy ta'lim muassasalarining ma'muriy, akademik, ilmiy-uslubiy, moliyaviy-xo'jalik faoliyatlarini avtomatlashtirish, oliy ta'lim muassasalari bilan vazirlik o'rtasida axborot almashinuvini yo'lga qo'yish hamda oliy ta'lim faoliyati qatnashchilari uchun elektron ta'lim xizmatlarini ko'rsatish masalalari ko'rilgan.

Kalit so'zlar: oliy ta'lim muassasasi, axborot tizimi, modellashtirish, akademik faoliyat, ilmiy-uslubiy faoliyat, avtomatlashtirish, raqamlashtirish, elektron ta'lim xizmatlari.



Copyright: © 2024 by the authors.

Ushbu maqola Creative Commons Attribution (CC BY) litsenziyasi shartlari asosida tarqatiladigan ochiq foydalanish maqolasi hisoblanadi (<https://creativecommons.org/licenses/by/4.0/>).



THE PROBLEM AND PROSPECTS OF DIGITALIZING PROCESSES OF MANAGEMENT AND MONITORING OF HIGHER EDUCATION

Abstract: The article is committed to issues of modeling, management, information system development, and implementation of higher education processes through the digitalization of higher education institutions. The article deals with the issues of automating the administrative, academic, scientific-methodical, and financial-economic activities of higher education institutions, establishing information exchange between higher education institutions and the ministry, and providing electronic education services for participants of higher education activities.

Keywords: higher education institution, information system, modeling, academic activity, scientific-methodical activity, automation, digitization, electronic education services.



Authors

Utkir Khamdamov

Department of Communication and Digital Technologies, "University of Management and Future Technologies",

Tashkent, 100208, Uzbekistan;
utkir.hamdamov@mail.ru

Alisher Abdullaev

Ministry of Higher Education, Science and Innovation,

Tashkent, Uzbekistan;

Khurshid Sultanov

Ministry of Higher Education, Science and Innovation,

Tashkent, Uzbekistan;

Shahrizoda Rakhmatillaeva

Department of Communication and Digital Technologies, "University of Management and Future Technologies",

Tashkent, 100208, Uzbekistan;

Correspondence: utkir.hamdamov@mail.ru



Copyright: © 2024 by the authors.

This article is an open access article distributed under the terms and conditions of the Creative Commons Attribution (CC BY) license (<https://creativecommons.org/licenses/by/4.0/>).

Kirish

Oliy ta'lim jarayonlarini boshqarish axborot tizimini ishlab chiqish hamda uni oliy ta'lim muassasalariga samarali tadbiq etish masalasi bilan bog'liq asosiy vazifalar O'zbekiston Respublikasi Prezidentining 2017 yil 22 martdagi PQ-2848-son qarori, 2020 yil 5 oktabrdagi "Raqamli O'zbekiston - 2030" strategiyasini tasdiqlash va uni samarali amalga oshirish chora-tadbirlari to'g'risida"gi PF-6079-son Farmoni, O'zbekiston Respublikasi Prezidenti Sh.M.Mirziyoev rahbarligida 2021 yil 16 iyun kuni "Oliy ta'lim sohasidagi islohotlar natijadorligi hamda yangi o'quv yiliga tayyorgarlik jarayonlari to'g'risida" o'tkazilgan videoselektor yig'ilishining 34-sonli bayoni, O'zbekiston Respublikasi Oliy va o'rta maxsus ta'lim vazirining 2020 yil 13 oktabrdagi Oliy ta'lim muassasalarida oliy ta'lim jarayonlarini boshqarish axborot tizimini joriy etish to'g'risidagi 535-son buyrug'i hamda 2021 yil 26 avgustdagi Oliy ta'lim muassasalarida "Oliy ta'lim jarayonlarini boshqarish - HEMIS" axborot tizimini joriy etish to'g'risidagi 372-son buyrug'i bilan belgilab berilgan.

Oliy ta'lim jarayonlarini raqamlashtirish va boshqarish axborot tizimini ishlab chiqishdan asosiy ko'zlangan maqsad vazirlik va oliy ta'lim muassasalari o'rtasida administrativ, akademik, ilmiy, va moliyaviy-xo'jalik axborotlarini almashish uchun yagona axborot muhitini yaratish; oliy ta'lim muassasalarining administrativ, akademik, ilmiy va moliyaviy - xo'jalik axborotlarini yig'ish, ishlov berish va taqdim qilish jarayonlarini avtomatlashtirish; oliy ta'lim ishtirokchilari va davlat boshqaruv organlariga axborot xizmatlari ko'rsatish va analitik ma'lumotlarni taqdim etish; oliy ta'lim sohasida boshqarish bo'yicha qarorlar qabul qilinishini qo'llab-quvvatlash va monitoring qilish; oliy ta'lim muassasalarining alohida faoliyat yo'nalishlari bo'yicha turli ko'rinishdagi hisobotlarni shakllantirish va taqdim etishni tashkil etishdan iborat hisoblanadi [1-2].

Bugungi kunda oliy ta'lim jarayonlarini boshqarish axborot tizimi muvaffaqiyatli ishlab chiqilib jami 221 ta oliy ta'lim muassasalariga (OTM) joriy etilgan jumladan, 120 ta (5 tasi harbiy OTM) Davlat OTMlariga, 25 ta xorijiy OTM filiallariga hamda 76 ta nodavlat OTMlarga joriy etilgan.

Hozirda axborot tizimining veb texnologiyalariga asoslangan platformasidan tashqari axborot tizimining mobil ilovasi ishlab chiqilib "GooglePlay" (550 mingdan ortiq yuklab olishlar) hamda "AppStore" (64 mingdan ortiq yuklab olishlar) mobil ilovalar do'konlariga joylashtirilgan hamda 600 mingdan ortiq foydalanuvchi foydalanib kelmoqda. Shuningdek, talabalarga qulaylik yaratish maqsadida Hemisedu_bot telegram boti ishlab chiqilib 150 mingdan ortiq foydalanuvchini qamrab olgan.

Bundan tashqari statistik ma'lumotlarni shakllantirish va tahlil etish hamda tegishli axborot is'temolchilariga taqdim etish maqsadida statistika dashboardi ham joriy etilgan.

1. HEMIS Axborot tizimini ishlab chiqish bosqichlari

Oliy ta'lim jarayonlarini boshqarish axborot tizimi 4 ta quyi tizimni o'z ichiga olib har biri quyidagi ketma-ketlikda bosqichma-bosqich ishlab chiqilgan va oliy ta'lim muassasalariga joriy etilgan [3-4]:

- axborot tizimining "o'quv jarayonini boshqarish" qismida oliy ta'lim muassasalarining akademik faoliyati, xususan, o'quv me'yoriy hujjatlari, talabalar kontingenti, talabaning davomat hisoboti, o'zlashtirish qaydnomasi va reyting daftarchasi, shartnoma va diplom hujjatlari shuningdek, guruh jurnali, dars va imtihon jadvallarini raqamlashtirish amalga oshirilgan;
- axborot tizimining «Ilmiy jarayonni boshqarish» qismida professor-o'qituvchilarning ilmiy loyihalari, maqolalari, ilmiy-uslubiy nashrlari, ilmiy izlanuvchilar to'g'risidagi ma'lumotlar bazasi shakllantirish hamda professor-o'qituvchilar va kafedralarning ilmiy salohiyatini baholash masalalari avtomatlashtirilgan;



- axborot tizimining «Ma'muriy jarayonni boshqarish» qismida oliy ta'lim muassasasining tuzilmasi, boshqaruv kadrlari, professor-o'qituvchilar tarkibi va talabalar to'g'risidagi ma'lumotlarni yuritish hamda tegishli hisobotlarni tayyorlashni raqamlashtirish amalga oshirilgan;
- axborot tizimining «Moliya-xo'jalik faoliyatini boshqarish» qismida oliy ta'lim muassasasi auditoriya fondi va AKT jihozlarining bazasi shakllantiriladi, talabalarning to'lov-shartnomalari va hisob-fakturalari elektron ko'rinishda taqdim etiladi, stipendiya to'lovlari to'g'risidagi ma'lumotlar tizim orqali amalga oshirish belgilangan.

2. HEMIS axborot tizimining boshqa tizimlar bilan integratsiyasi.

HEMIS axborot tizimi orqali boshqa davlat idoralari va tashkilotlarining axborot tizimlariga elektron hukumatning idoralararo integratsion platformasi orqali oliy ta'lim muassasalari talabalari va professor-o'qituvchilari hamda OTMning o'quv faoliyatiga tegishli hujjatlar to'g'risidagi ma'lumotlar uzatiladi.

Jumladan, Axborot tizimi asosida shakllantirilgan ma'lumotlar bazalari Iqtisodiyot va moliya vazirligining "Yagona ijtimoiy himoya reestri", "UzASBO", "Ta'lim krediti", "Pensiya jamg'armasi", Markaziy bankning "MUNIS kliring tizimi", Toshkent shahar hokimligining "Geoaxborot tizimi", Hisob palatasining "Masofaviy nazorat" axborot tizimi, Aloqabank AT bankining "Zoomrad mobil ilovasi", "Universal talaba kartasi", Transport vazirligining "O'zbekiston temir yo'llari", "O'zbekiston havo yo'llari", Soliq qo'mitasining "Ijara" tizimi, Markaziy saylov komissiyasining axborot tizimi, Bilim va malakalarni baholash agentligining "Virtual markaz interaktiv xizmatlar portali", Yoshlar ishlari agentligining "Yoshlar daftari", Kambag'allikni qisqartirish va bandlik vazirligining "Yagona milliy mehnat tizimi", Maktabgacha va maktab ta'limi vazirligining "attestat.uzedu.uz" axborot tizimiga integratsiya qilingan.

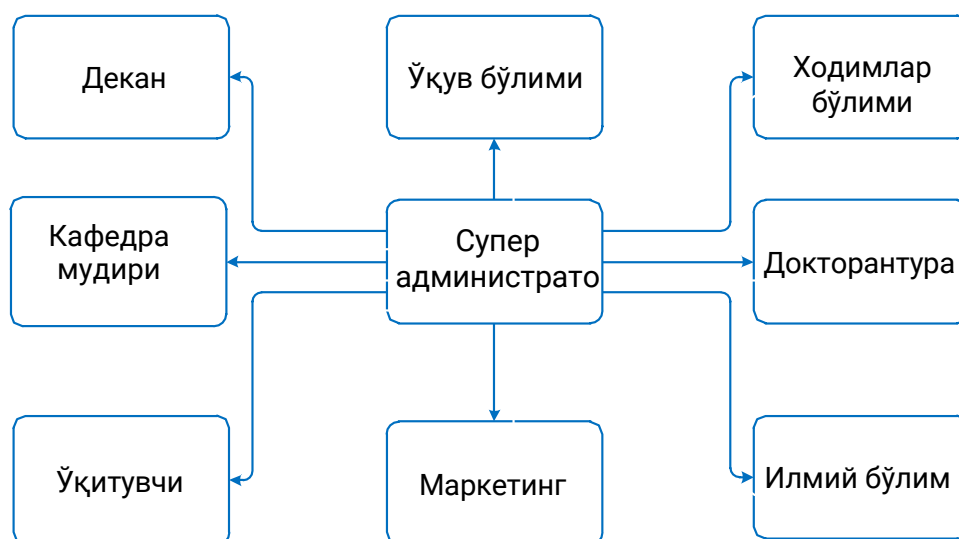

1-rasm. Axborot tizimining rollari strukturasi.

Aholi va tadbirkorlik subektlariga elektron ko'rinishdagi xizmatlarni ko'rsatish ko'lamini kengaytirish hamda yagona yondashuvni ta'minlash maqsadida HEMIS axborot tizimi va Yagona interaktiv davlat xizmatlari portali (my.gov.uz) o'rtasida doimiy ma'lumot almashish jarayonlari amalga oshirilmogda.

Bundan tashqari HEMIS axborot tizimi Vazirlikning ichki axborot tizimlari bilan integratsiya qilinishi natijasida ikkinchi mutaxassislikka ariza topshirish, shartnoma olish, magistraturaga kirish uchun hamda o'qishni ko'chirish yoki tiklash uchun ariza yuborish imkoniyatlari yaratildi.

3. HEMIS axborot tizimi foydalanuvchilarini rolli boshqaruv mexanizmi.

HEMIS axborot tizimida jarayonlarni tashkil etish va boshqarishda foydalanuvchilar toifalari va rollarga murojaat qilingan. Rollar o'z navbatida axborot tizimini shakllantirish va undan foydalanishda yuqori samaradorlikni taqdim etadi.

HEMIS axborot tizimida quyidagiga 17 turdagi rollar mavjud: Super administrator, Dekan, Kafedra mudiri, o'qituvchi, o'quv bo'limi, Marketing bo'limi, Kadrlar bo'limi, Doktorantura bo'limi, Ilmiy bo'lim, Buxgalteriya, Kichik admin, Kutubxona, Moliya-nazorati, Raxbariyat, Registrator ofis, Tyutor, Yotoqxon mas'uli

4. HEMIS axborot tizimining samaradorlik ko'rsatkichlari.

Axborot tizimini joriy etish natijasida quyidagi samaradorlik va imkoniyatlarga erishildi:

- Ma'lumotlarni shakllantirish va ularni qayta ishlash imkoniyati yaratildi va 35 dan ortiq turli hisobotlar va statistik ma'lumotlar elektron ko'rinishga o'tkazildi;
- Talaba o'qish joyidan ma'lumotnoma, transkript, reyting daftarcha, diplom ma'lumotlar, shartnoma ma'lumotlari raqamlashtirildi;
- Vazirlik va idoralarning jami 22 ta axborot tizimi bilan o'zaro ma'lumot almashinishi tashkil etilib yagona interaktiv davlat xizmatlari portalida (my.gov.uz) 9 ta davlat xizmati ishga tushirildi;
- Talabalar kontingentining hisobi va monitoringini yuritish (fakultetlar, ta'lim yo'nalishlari, mutaxassislik va akademik guruhlar kesimida);
- Professor-o'qituvchilar kontingentining hisobi va monitoringini yuritish (fakultetlar, kafedralar va fanlar kesimida);
- o'quv jarayonini tashkil etish (o'quv yili, o'quv semestrlari, bakalavriat va magistratura o'quv dasturlari, talabalar akademik guruhlari uchun dars jadvali);
- Talabalar davomati monitoringini yuritish (fanlar, mashg'ulot turlari, o'qituvchilar, dars jadvali va elektron jurnal);
- Talabalar fanlar bo'yicha o'zlashtirish monitoringi (o'quv reja va fanlar, oraliq va yakuniy imtihonlar jadvali, reyting qaydnomasi, elektron reyting daftarchasi);
- To'lov-shartnoma bo'yicha amalga oshirilgan to'lovlar hisobi (shartnomalar va hisob varaqalarni ro'yxatga olish, pul tushumlarini hisobga olish, ma'lumotnomalar taqdim etish);
- Interaktiv onlayn xizmatlarni taqdim etish (OTM rahbariyati, talabalar, o'qituvchilar, ota-onalar



va davlat idoralari xodimlari uchun) imkoniyatlari yaratildi.

Xulosa

Xulosa qilib aytganda ushbu axborot tizimi davlat oliy ta'lim muassasalarining ma'muriy boshqaruv, o'quv, ilmiy va moliyaviy faoliyatini raqamlashtirishga qaratilgan bo'lib 35 dan ortiq turli hisobotlar va statistik ma'lumotlar faqat elektron tarzda shakllantirilmoqda. Talabalarning guruh jurnallari, o'zlashtirish qaydnomalari to'liq raqamlashtirilib respublika bo'yicha qog'oz sotib olish uchun xar yili sarflanadigan 2 milliard so'mdan ortiq mablag'ni tejashga erishilmoqda.

Axborot tizimini joriy etish natijasida ma'lumotlarni onlayn shakllantirish, ortiqcha vaqt va resurslar tejash, faoliyatni ochiqligini ta'minlash bilan bir qatorda quyidagi yo'nalishlarda sezilarli darajada iqtisodiy samaradorlik kuzatildi.

Adabiyotlar

1. Исаева Е. С. Современные LMS платформы дистанционного обучения: анализ и сравнение. // Педагогика. Вопросы теории и практики. 2021. Том 6. Выпуск 6. С. 1045-1050
2. Jamshid Elov, Utkir Khamdamov, Inomjon Narzullayev, Djamshid Sultanov, Alisher Abdullaev. Development of a database of higher education process management information system based on the relational model. // International conference on information science and communications technologies Applications, Trends and Opportunities (ICISCT 2021). Tashkent -2021. 3-5 November. 4p.
3. Abdullaev A. Oliy va o'rta maxsus ta'lim vazirligi uchun oliy ta'lim jarayonlarini boshqarish axborot tizimining funksional imkoniyatlari. // Muxammad al-xorazmiy avlodlari ilmiy-amaliy va axborot tahliliy jurnal. 4(22)/2022. –B.30-35
4. Хамдамов У. Перспективы внедрения информационной системы управление высшим образованием. // “Iqtisodiyot tarmoqlarining innovatsion rivojlanishida axborot-kommunikatsiya texnologiyalarining ahamiyati” Respublika ilmiy-texnik anjumani ma'ruzalar to'plami. 2022 йил 10-11 mart, Toshkent - 2022. – В. 6-9



Authors

Mukhiddinov Mukhriddin

Department of Communication and Digital Technologies, University of Management and Future Technologies,

Tashkent 100208, Uzbekistan;
mukhiddinov@umft.uz

Djuraev Oybek

Department of Communication and Digital Technologies, University of Management and Future Technologies,

Tashkent 100208, Uzbekistan;
djurayev@umft.uz

Djuraev Jasurbek

Department of Software Engineering, Tashkent University of Information Technologies named after Mukhammad al-Khwarizmi, Tashkent 100200, Uzbekistan;

Rakhmatillaeva Shakhriyoda

Department of Communication and Digital Technologies, University of Management and Future Technologies,

Tashkent 100208, Uzbekistan;

Correspondence: mukhiddinov@umft.uz



Copyright: © 2024 by the authors.

This article is an open access article distributed under the terms and conditions of the Creative Commons Attribution (CC BY) license (<https://creativecommons.org/licenses/by/4.0/>).

THE ROLE AND PROSPECTS OF DIGITAL AND INNOVATIVE TECHNOLOGIES IN EDUCATION FOR THE VIZUALLY IMPAIRED PEOPLE

Abstract: In the realm of aiding the visually impaired and blind population, challenges arise in enabling independent mobility and mitigating daily obstacles. To address these concerns, the integration of artificial intelligence and computer vision methodologies offers promising solutions for individuals with visual impairments, reducing their reliance on external assistance. Smart glasses emerge as a prospective assistive technology, serving to enhance autonomous navigation and fostering a sense of social security and convenience. Nevertheless, practical limitations persist for the visually impaired, notably in navigating dark environments and during nighttime hours. This research endeavors to propose a smart glass system tailored for individuals with visual impairments, leveraging sophisticated computer vision techniques, deep learning models, auditory cues, and tactile graphics. The primary aim is to empower autonomous movement within nighttime settings, fostering self-sufficiency and safety for the visually impaired demographic. The architecture comprises four distinct models: a low-light image enhancement model, an object recognition system integrated with audio feedback, a salient object detection model, and a text-to-speech mechanism coupled with tactile graphics generation.

Keywords: smart glasses; artificial intelligence; blind and visually impaired; deep learning; assistive technologies; object detection; refreshable tactile display.

Introduction

In the contemporary landscape of information and communication technology, the lifestyle and autonomous mobility of individuals with visual impairments constitute a paramount societal concern. Governments and specialized organizations have instituted numerous laws and standards, establishing essential infrastructure to support those with visual disabilities. According to the World Health Organization, as of 2020, a staggering 2.2 billion individuals globally grapple with vision impairment or blindness, with at least 1 billion facing preventable or unaddressed vision impairments [1]. The causes encompass diverse factors, including cataracts (94 million), unattended refractive errors (88.4 million), glaucoma (7.7 million), corneal opacities (4.2 million), diabetic retinopathy (3.9 million), trachoma (2 million), among others [1].

The primary challenges confronting individuals who are blind or visually impaired (BVI) in their daily lives revolve around issues of action and environmental awareness. Numerous solutions have been proposed, leveraging navigation and object recognition methodologies. However, widely adopted navigation aids, such as canes, trained guide dogs, and smartphone applications, exhibit inherent limitations. For instance, canes prove ineffective over extended distances and in crowded environments, lacking the ability to relay information about hazards or vehicular traffic when navigating streets. Similarly, the training and upkeep of guide dogs are laborious and costly, demanding special attention. Moreover, while smartphone applications like voice assistance and navigation maps tailored for BVI individuals are advancing, their comprehensive and proficient utilization remains relatively low.

Smart glasses stand out as a preferred wearable assistive technology for individuals with visual impairments, offering both comfort and functionality akin to a computer. Since Google introduced “Google Glass” in 2013 targeting the visually impaired, numerous companies like Epson, Sony, Microsoft, Envision, eSight, NuEyes, OxSight, and OrCam have entered the market, each offering smart glasses with varying levels of usability. These devices commonly feature an embedded operating system, supporting wireless connectivity via Wi-Fi or Bluetooth..

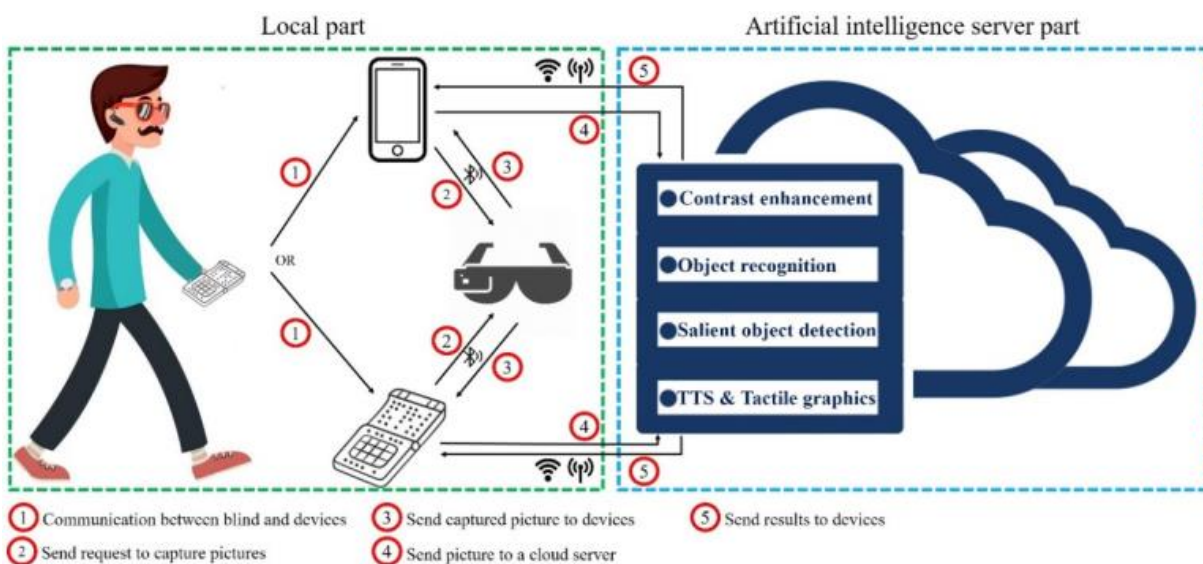

Figure 1. The overall design of the proposed system.



Proposed System

Our aim is to enhance the autonomy of individuals with visual impairments by enabling independent travel, both during the day and at night. To accomplish this objective, we've devised a wearable smart glass system integrated with a multifunctional setup. This system employs a miniature camera to capture images, leveraging object recognition technology to provide users with auditory feedback. Additionally, for tactile interaction, we've incorporated a refreshable display that allows users to explore detected salient objects by touch, catering to the specific needs of the visually impaired. To ensure precise object detection, our system relies on deep Convolutional Neural Networks (CNNs), necessitating a robust processor for real-time processing. Thus, we've devised a client-server architecture that comprises the smart glass and a smartphone (referred to as a tactile pad for simplicity). This local setup communicates data via a Bluetooth connection. Simultaneously, an artificial intelligence server receives the captured images from the local setup, executes image processing tasks, and relays the results in audio format. The overall design of our proposed system is depicted in Figure 1. The local component encompasses the smart glass and smartphone, facilitating data transfer via Bluetooth. Meanwhile, the artificial intelligence server processes received images and transmits the outcomes in audio format. It's important to note that the smart glass hardware includes a built-in speaker for direct output and an earphone port for users to access the audio results relayed from the smartphone.

To enable object recognition, we implemented a transformer-based encoder-decoder design [2], renowned for its efficacy in sequence prediction tasks. Transformers' self-attention mechanisms, adept at modeling intricate interactions within sequences, make them well-suited for addressing prediction constraints, notably in eliminating redundant predictions. Specifically, the Detection Transformer (DETR) adopts a unique approach by simultaneously predicting all objects and training end-to-end using a unified loss function to establish bipartite matching between predicted and actual objects [2]. Notably, DETR distinguishes itself from conventional detection methods by obviating the need for custom layers, offering flexibility within structures combining standard CNN and transformer attributes. Experimental findings demonstrated DETR's commendable accuracy in detecting larger objects. However, its performance diminished when detecting smaller objects. The DETR network comprises four key components: (1) a CNN backbone to extract concise feature representations, (2) a transformer encoder, (3) a transformer decoder, and (4) a straightforward feedforward network (FFN) responsible for generating the final detection predictions.

Individuals with visual impairments can benefit from voice feedback not only regarding the presence of surrounding objects but also concerning textual information within natural scenes. This is particularly crucial in daily life as text data provides precise and unambiguous descriptions of the environment, aiding blind and visually impaired individuals in accessing vital visual information. Text is prevalent on diverse objects in natural settings, including billboards, road signs, and product packaging. However, recognizing scene text poses challenges due to factors such as illumination variations, blurring, color differences, complex backgrounds, suboptimal lighting conditions, noise, and discontinuities. To address these challenges, we employed our previously developed real-time end-to-end scene text recognition system, alongside the Tesseract OCR engine [72]. This combination enabled us to achieve robust and accurate results when working with datasets such as ExDark, LOL, and our captured natural scene images.

One distinguishing feature of our smart glass system, setting it apart from existing solutions, is its capacity to generate tactile graphics. This functionality empowers the blind by offering visual information through the depiction of salient objects' contours. Additionally, we employed specialized software for the tactile display system [3] to aid the blind and visually impaired in perceiving and identifying elements within natural scene images.



Models	Backbone Network	AP	AP ₅₀	AP ₇₅	AP _S	AP _M	AP _L
OHEM [4]	VGGNet16	21.3	40.3	21	4.3	21.5	36.8
Faster RCNN w FPN [5]	ResNet101-FPN	35.4	57.9	38.3	16.4	37.4	47.3
RetinaNet [6]	ResNeXt101-FPN	38.6	59.3	43.2	22.8	43.4	50.5
RefineDet512+ [7]	ResNet101	40.1	61.3	43.8	24.4	43.8	52.9
RFBNet512-E [8]	VGGNet16	33.1	53.2	34.7	15.9	36.1	46.3
CornerNet511 [9]	Hourglass104	40.8	55.7	43.4	19.6	43.2	55.7
DETR [10]	ResNet101	45.3	63.5	50.3	26.4	48.9	60.7

Experimental Results

The performance assessment of our object detection models on low-light images involved the evaluation of the DETR model in comparison to 10 other state-of-the-art models. These models include OHEM [4], Faster RCNNwFPN [5], RetinaNet [6], RefineDet512+ [7], RFBNet512-E [8], and CornerNet511 [9]. Performance comparisons were conducted utilizing the results presented in the respective papers and the source code provided by the authors. Quantitative analysis was performed employing established metrics, including Precision, Recall, and AP. Precision and recall rates were computed by comparing pixel-level ground truth images with the outcomes generated by the proposed method. The comparative findings between the DETR model and other cutting-edge models, all of which have been published in prestigious conferences and journals like CVPR, ICCV, ECCV, and AAAI in recent years, are outlined in Table 1.

Table 1. The performance comparison of DETR with other state-of-the-art methods on LOL and ExDark datasets. The best results are marked with bold. S: small objects, M: medium objects, L: large objects.

Conclusion

This paper outlines a smart glass system integrating computer vision and deep learning models for individuals with visual impairments. The system encompasses object detection, salient object extraction, and text recognition modules, operating seamlessly on an artificial intelligence server. Designed to be fully autonomous, the system effectively identifies and recognizes objects within low-light and dark-scene images, thereby facilitating navigation for individuals with visual impairments in nocturnal environments. Significantly advancing beyond conventional smart glass systems, this approach incorporates deep learning models, introducing salient object extraction for tactile graphics and text recognition for the conversion of text to speech.

References

1. Steinmetz, J.D.; Bourne, R.R.; Briant, P.S.; Flaxman, S.R.; Taylor, H.R.; Jonas, J.B.; Abdoli, A.A.; Abrha, W.A.; Abualhasan, A.; Abu-Gharbieh, E.G.; et al. Causes of blindness and vision impairment in 2020 and trends over 30 years, and prevalence of avoidable blindness in relation to VISION 2020: The Right to Sight: An analysis for the Global Burden of Disease Study. *Lancet Glob. Health* 2021, 9, e144–e160.
2. Carion, N.; Massa, F.; Synnaeve, G.; Usunier, N.; Kirillov, A.; Zagoruyko, S. End-to-end object detection with transformers. In *European Conference on Computer Vision*; Springer: Cham, Switzerland, 2020; pp. 213–229.
3. Kim, S.; Ryu, Y.; Cho, J.; Ryu, E. Towards Tangible Vision for the Visually Impaired through 2D Multiarray Braille Display. *Sensors* 2019, 19, 5319.
4. Shrivastava, A.; Gupta, A.; Girshick, R. Training region-based object detectors with online hard example mining. In *Proceedings of the IEEE Conference on Computer Vision and Pattern Recognition (CVPR)*, Las Vegas, NV, USA, 26 June–1 July 2016.
5. Lin, T.Y.; Dollar, P.; Girshick, R.; He, K.M.; Hariharan, B.; Belongie, S. Feature pyramid networks for object detection. In *Proceedings of the IEEE Conference on Computer Vision and Pattern Recognition (CVPR)*, Honolulu, HI, USA, 21–26 July 2017.
6. Lin, T.; Goyal, P.; Girshick, R.; He, K.; Dollr, P. Focal loss for dense object detection. In *Proceedings of the IEEE International Conference on Computer Vision (ICCV)*, Venice, Italy, 22–29 October 2017.
7. Zhang, S.; Wen, L.; Bian, X.; Lei, Z.; Li, S.Z. Single-shot refinement neural network for object detection. In *Proceedings of the IEEE Conference on Computer Vision and Pattern Recognition (CVPR)*, Salt Lake, UT, USA, 18–22 June 2018.
8. Liu, S.; Huang, D.; Wang, Y. Receptive field block net for accurate and fast object detection. In *Proceedings of the IEEE Conference on Computer Vision and Pattern Recognition (CVPR)*, Salt Lake, UT, USA, 18–22 June 2018.
9. Law, H.; Deng, J. Cornernet: Detecting objects as paired keypoints. In *Proceedings of the European Conference on Computer Vision (ECCV)*, Munich, Germany, 8–14 September 2018.
10. Carion, N.; Massa, F.; Synnaeve, G.; Usunier, N.; Kirillov, A.; Zagoruyko, S. End-to-end object detection with transformers. In *European Conference on Computer Vision*; Springer: Cham, Switzerland, 2020; pp. 213–229.



VIDEOMONITORING HOSSALARIGA ASOSLANGAN MASOFAVIY TA'LIM JARAYONLARINI TAKOMILLASH- TIRISHNING AXBOROT MODELI

Annotatsiya: So'nggi bir ikki yil ichida ta'lim sohasida ulkan o'zgarishlar sodir bo'ldi deb aytish mumkin. Ta'lim tizimi COVID-2019 pandemiyasi tufayli o'quvchi va talabalarni ko'proq resurslar bilan ta'minlash uchun ta'limning masofaviy shaklidan foydalana boshlashdi. Buning ortidan proktoring tizimlarga bo'lgan talabalar ham o'z navbatida o'sa boshladi. Sun'iy intellektga asoslangan avtoproktoring tizimlar esa masofaviy ta'limga shiddan bilan kirib keldi. Onlayn proktoring tizimlari masofaviy ta'lim va imtihon jarayonlarini o'tkazishda shafoflikni ta'minlash uchun foydalanildi. Ushbu maqolada sun'iy intellektga asoslangan proktoring tizimlarni ishlab chiqishning axborot modeli taklif etilgan.

Kalit so'zlar: Sun'iy intellekt, proktoring, tizimlar, tasvir, masofaviy talim.



Mualliflar

Sirojiddin Xalilov

Kommunikatsiya va raqamli texnologiyalar kafedrası, "University of management and future technologies" universiteti,

Toshkent, 100208, O'zbekiston;
kh.surajiddin@gmail.com

Farangiza Omonullaeva

Raqamli texnologilar kafedrası, Alfraganus universiteti,

Toshkent, 100208, O'zbekiston;

Maftuna Mannapova

Raqamli texnologilar kafedrası, Alfraganus universiteti,

Toshkent, 100208, O'zbekiston;

Mas'ul: kh.surajiddin@gmail.com



Copyright: © 2024 by the authors.

Ushbu maqola Creative Commons Attribution (CC BY) litsenziyasi shartlari asosida tarqatiladigan ochiq foydalanish maqolasi hisoblanadi (<https://creativecommons.org/licenses/by/4.0/>).



Mualliflar

Sirojiddin Khalilov

Department of Communication and Digital Technologies, "University of Management and Future Technologies",

Tashkent, 100208, Uzbekistan;
kh.surajiddin@gmail.com

Farangra Omonullaeva

Department of Digital Technologists, Alfraganus University,

Tashkent, 100208, Uzbekistan;

Maftuna Mannapova

Department of Digital Technologists, Alfraganus University,

Tashkent, 100208, Uzbekistan;

Correspondence: kh.surajiddin@gmail.com



Copyright: © 2024 by the authors.

This article is an open access article distributed under the terms and conditions of the Creative Commons Attribution (CC BY) license (<https://creativecommons.org/licenses/by/4.0/>).

INFORMATION MODEL OF IMPROVING DISTANCE EDUCATION PROCESSES BASED ON VIDEO MONITORING PROPERTIES

Abstract: In the last one or two years, it can be said that tremendous changes have taken place in the field of education. Due to the COVID-2019 pandemic, the education system has started using distance learning to provide more resources to students. After that, the number of students in proctoring systems also began to increase. And artificial intelligence-based autoproctoring systems have made inroads into distance learning. Online proctoring systems have been used to ensure transparency in conducting distance learning and examination processes. This paper proposes an information model for the development of proctoring systems based on artificial intelligence.

Keywords: Artificial intelligence, proctoring, systems, image, distance learning.



Butun jaxon bo'yicha talim tizimi evolyusion rivojlanmoqda. So'ngi yil mobaynida masofaviy talim tizimi ham sezilarli suratda rivojlandi. Bundan tashqari, COVID-19 pandemiyasi masofaviy talimni joriy etishga katta ta'sir ko'rsatdi. Pandemiya butun dunyoni yopiq hududlarga majburlaganiligi sababli, talim sektorlari masofaviy talim jarayoniga o'tish bilan bir qancha muammolar paydo bo'lishiga olib keldi.

Birinchi qiyinchilik talim oluvchilarning talim olish jarayonida har hil qoidabuzarliklarni sodir etishlari (dars mashg'ulotlariga kirmasligi, o'rniga org'oti ishtiroki, yoki umuman tizimdan foydalanmaslik). Ushbu muammolarni hal qilish bo'yicha talim muassalari ilmiy izlanishdar olib bormoqda. Bunda olimlar asosiy etiborni imtixon jarayonlari tashkil etish va boshqarishga samarali echimlarni taklif etishgan. Masofadan turib imtixonlarni tashkil etish va uni boshqarish tizimlarda videomonitoring (proktoring) qilish jarayonlar jaxon bo'yicha ilmiy tadqiqotchilar samarali natijalarga erishgan. Ammo masofaviy talim jarayoni tashkil etish, boshqarish va talim oluvchilar nazorat qiluvchi tizimlar ishlab chiqish bo'yicha yetarli muammolar mavjud. Masofadan turib imtixonlari tashkil qiluvchi tizimlarning barcha nazorat foydalunchilar nazorat qilishda barcha hususiyatlar mavjud lekin ular asosan yakuniy test sinovlarini nazorat kilishga mo'ljallangan.

Masofaviy nazorat - bu onlayn imtixon jarayonini kengaytiriladigan tarzda autentifikatsiya qilish, ruxsat berish va nazorat qilish jarayonidir. Bu to'liq xavfsizlik standartlarini ta'minlab, tashkilotlarga istalgan joyda va istalgan vaqtda baholash imkonini beradigan jarayon. Boshqacha qilib aytganda, foydalanuvchilar malum bir joyga kelishlari shart emas, chunki ular o'z uylaridan dars mashg'ulotlari o'zlashtirishlar va imtixon topshirishlari mumkin.

An'anaviy imtixon jarayonini oladigan bo'lsak, imtihonga kelgan nomzodlarni tekshirish uchun imtixon markazida nazoratchi bo'lishi kerak. 30-40 nomzodni tekshirish uchun sizga bitta nazoratchi kerak, ammo 1000 dan ortiq nomzoddan imtixon topshirish uchun sizga imtixon jarayonini nazorat qiluvchi 25 dan ortiq nazoratchi kerak bo'ladi. Bu bevosita ish kuchi va mablag'ga bog'liq.

Onlayn proktoring tizimlarida esa nomzodning veb-kamerasi va internet tarmog'idan foydalanib amalga oshirilishi mumkin. U har bir imtixon seansini boshidan oxirigacha faqat video orqali emas, balki ish stoli ekranlaridagi suhbat jurnallari va nazorat qilib boradi.

Xozirgi kunda zamonaviy sunniy intellekt texnologiyalari yordamida masofadan talim foydalanuvchilarni samarali nazorat qilish mumkin. Bundan talim istalgan vaqtda, istalgan joydan turib o'quv materiallari va test imtixonlarini markazlashgan platformadan topshirish imkoniyati yaratib beradi.

Sunniy intellekt texnologiyalariga qo'llab-quvvatlaydigan avtoproktoring tizimlaridan foydalanish doimiy ravishda moslashishni o'rganishi va aqlliroq bo'lishi mumkin. Sunniy intellektni proktoringga joriy etishdan maqsad odamlarni almashtirish emas, balki odamlarga past ovozli shivirlash, soyalarni aks ettirish kabi hususiyatlarni aniqlashda yordam berish orqali proktoringning aniqligini oshirishdir. Sunniy intellektni qo'llab-quvvatlaydigan masofadan turib tekshirish quyidagi uchta sohaga qaratilgan, identifikatsiya firibgarligini aniqlash, aldash xatti-harakatlarini tahlil qiling, kontentni o'g'irlashni tahlil qilish.

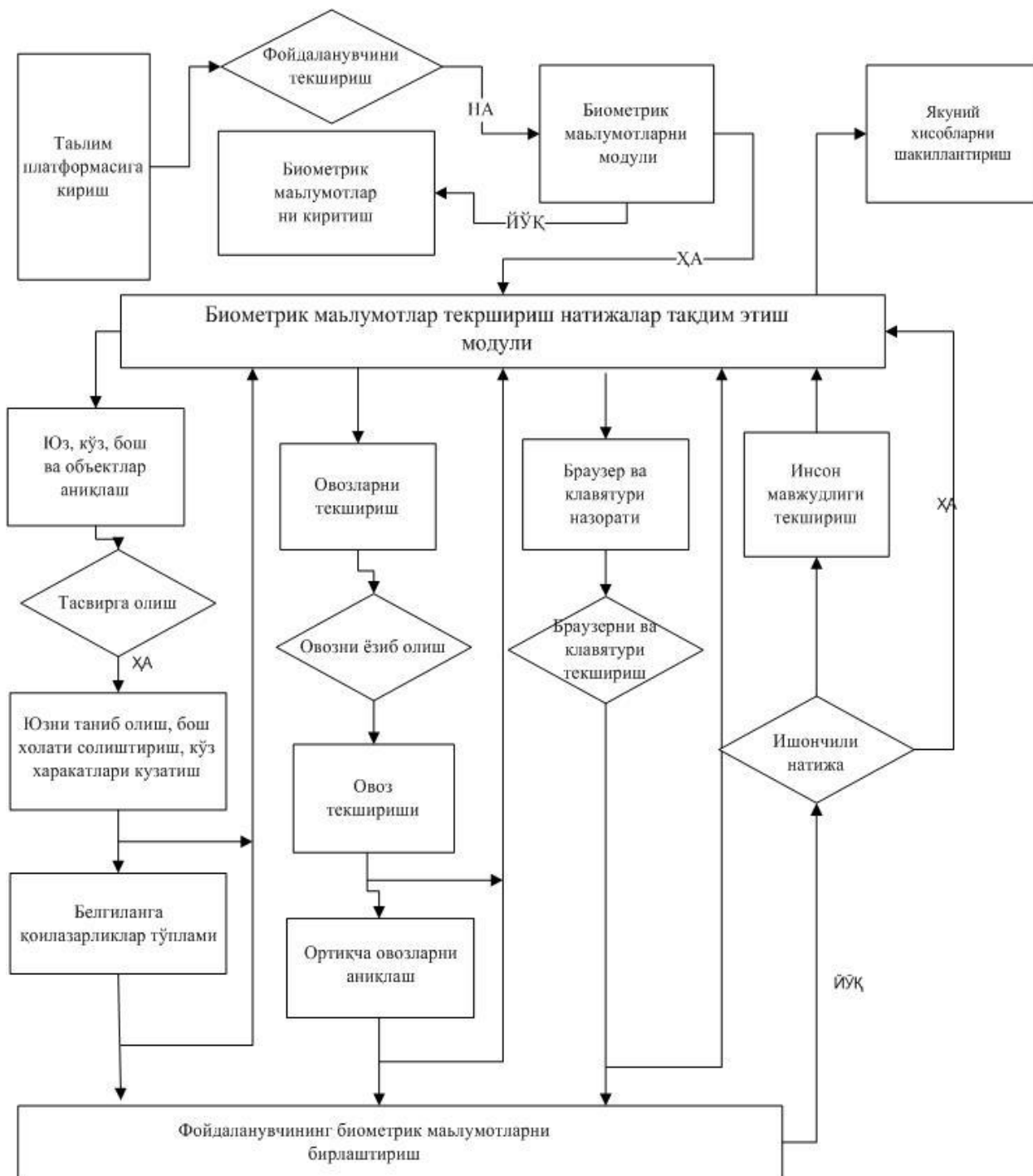

1-rasm. Videomonitoring hossalriga asoslangan masofaviy ta'lim jarayonlarining axborot modeli



Asosiy qism

Taklif etilayotgan ishda yuzni tanib olish, boshning, ko'zning holatining muvofiqligi tekshirish hamda kerakli karorlarni qabul qilishdan tashqari ushbu tizimdan foydalanish jarayonida yangi imtihon vaqtdan bir necha yuzlar, ko'shimcha tovushlar va aksessuarlar aniqlab xulosalar taqdim etiladi.

Masofaviy ta'lim jarayonida videomonitoring tizimini ishlab chiqishda quyidagi bosqichlarni o'zi mujassamlagan bo'lishi kerak.

Foydalanuvchi bosqichi;

Hizmat ko'rsatuvchi texnik bosqich;

Yakuniy xulosalarni taqdim etish bosqichi;

Yuqorida taklif etilgan ko'p bosqichli videomonitoring tizimning ichki modullari mavjud.

Ma'lumotlarni to'plash va saqlash moduli – Ushbu modulda talaba kompyuterining veb kamerasi, mikrofoni va klavyaturasidan malumotlar olinadi. Ushbu malumotlar foydalanuvchi identifikatsiya kodi bilan serverga shifrlangan SSL kanali orqali yuboriladi.

Autentifikatsiya moduli - Barcha ma'lumotlar serverlarda saqlanganidan so'ng, talaba ro'yxatdan o'tish vaqtida yaratilgan va oxirgi ijobiy ma'lumotlar bilan yangilangan identifikatsiya kodi bilan bog'langan biometrik model bilan taqqoslanadi. Natija tizimning ma'lumotlar bazasida saqlanadi.

Proktoring (nazorat) va kompyuter bloklash moduli - Videomonitoring tizimi onlayn mashg'ulotlar davomida yozib oling tasvir va audio yozuvlar yozib boriladi va mashg'ulotlar davomida talabalar nomaqbul xatti-harakatlarini aniqlash uchun kayta ishlov beriladi. Shundan so'ng tizim talaba mashg'ulot va nazoratlarni topshirish vaqtida ko'shimcha yordam olayotganligini (telfon orqali, yonidagi boshqa talaba) yoki taqiqlangan hujjatlardan (elektron kitoblar, maruza mantlar va internetga ulangan boshqa qurilmalar....) foydalanmasligi nazorat qila oladi. Bundan tashqari, agar biror talaba tizimni aldashga harakat qilsa, masalan, kamera oldiga fotosurat o'rnatish yoki ID karta tasvirini boshqa birovning kartasiga almashtirish kabi aldashlarga urinsa tizim tomonidan aniqlanadi va nazoratchi xabar qilinadi.

Insonni tekshirish moduli:

Bunda registrasiya qilingan malumotlar bilan sessiya davomida olingan ovozli yozuvlar, videotasvirlar va tugmachalarni bosish namunalari tasodifiy malumotlari bilan (turli odamlar tomonidan tahlil qilingan bir xil videotasvirlar, ovozli yozuvlar va tugmachalarni bosish namunalari) o'zaro tekshiruviga asoslanadi.

Bundan tashqari, fotosuratlar yoki ovoz sifati yaxshi bo'lmagan taqdirda, maxsus o'qitilgan xodimlar talabani 100% ishonch tekshiruvini ta'minlaydigan shaxs ishtokidagi yuzma yuz tekshiruvi o'tkaziladi.

Natijalarni ko'rish moduli:

Yakuniy nazorat natijalari malumotlarni ushbu moduli tomonidan taqdim etiladi. U dinamik veb-sahifa sifatida 24 soat/365 kun talab bo'yicha grafik diagrammalar va jadvallarni yaratadi. Yakuniy hisobotlarni turli formatlarda yuklab olish yoki chop etish mumkin. Bundan tashqari, malumotlarni taqdim etish moduli oldindan belgilangan taqiqlangan xatti-harakatlar sodir bo'lganda avtomatlashtirilgan signallarni ishlab chiqaradi.

Tizim autentifikatsiya jarayonlari fakat foydalanuvchilar tizimga kirganlarida emas, balki butun sessiya davomida baholashdan tashqari fan bo'yicha shakillantirilgan maruza va amaliyot materiallarini o'zlashtirish jarayonlarini ham nazorat qilishi lozim.

Adabiyotlar

1. Arora, P. (2021). Is Remote Proctoring The Future Of Academia? - eLearning Industry.
2. Atoum, Y., Chen, L., Liu, A. X., Hsu, S. D. H., & Liu, X. (2017). Automated Online Exam Proctoring. *IEEE Transactions on Multimedia*, 19(7), 1609–1624. <https://doi.org/10.1109/TMM.2017.2656064> Beust, P., Duchatelle, I., & Cauchard, V.
3. S.Xalilov, M.Mardiyev “Masofaviy ta’lim jarayonida avtoproktoring tizimlarining istiqbollari” *juornal Innovations in technology and science education SJIF 2023: 5.503 volume 2 ISSUE 8.*
4. Draaijer, S., Jefferies, A., & Somers, G. (2018). Online proctoring for remote examination: A state of play in higher education in the EU. *Communications in Computer and Information Science*, 829, 96–108. https://doi.org/10.1007/978-3-319-97807-9_8.
5. Caveon, D. F., Security, T., & Layman, H. (2013). Online Proctoring Systems Compared.
6. Chua, S. S., Bondad, J. B., Lumapas, Z. R., & Garcia, J. D. (2019). Online Examination System with Cheating Prevention Using Question Bank Randomization and Tab Locking.
7. Coghlan, S., Miller, T., & Paterson, J. (2020). Good proctor or “Big Brother”? AI Ethics and Online Exam Supervision Technologies. *ArXiv Preprint*.
8. Dendir, S., & Maxwell, R. S. (2020). Cheating in online courses: Evidence from online proctoring. *Com- puters in Human Behavior Reports*, 2, 100033. <https://doi.org/10.1016/j.chbr.2020.100033>

ELEKTRON SO‘ZLARNI VEKTORLI IFODALASH TEXNOLOGIYASI

Annotatsiya: Tabiiy tilni qayta ishlash texnologiyalarini ishlab chiqish va samarali foydalanishni tashkil etish bugungi kunning dolzarb maslalaridan biridir. Ushbu ishda elektron matndagi so‘zlarni qidirish va ma’no jihatidan tahlil qilishni tashkil etishda qo‘llaniladigan samarali texnologiyalardan biri bo‘lgan so‘zni vektorli ifodalash texnologiyalari haqida so‘z yuritilgan. Xususan, Word2vec texnologiyasi bo‘yicha so‘zni vektor qiymatlarini aniqlash jarayoni tushuntirilgan.

Kalit so‘zlar: matn, so‘z, texnologiya, vektor, Word2vec, Ochiai koeffitsiyenti, GloVe.



Muallif

Baxtiyor Akmuradov

Kommunikatsiya va raqamli texnologiyalar kafedrasini, "University of Management and Future Technologies" universiteti,

Toshkent, 100208, O‘zbekiston;
b.u.akmuradov@gmail.com

Mas’ul: b.u.akmuradov@gmail.com



Copyright: © 2024 by the authors.

Ushbu maqola Creative Commons Attribution (CC BY) litsenziyasi shartlari asosida tarqatiladigan ochiq foydalanish maqolasi hisoblanadi (<https://creativecommons.org/licenses/by/4.0/>).



Authors

Bakhtiyar Akmuradov

Department of Communication and Digital Technologies, University of Management and Future

Technologies, Tashkent, 100208, Uzbekistan; b.u.akmuradov@gmail.com

TECHNOLOGY OF VECTOR REPRESENTATION OF ELECTRONIC WORDS

Abstract: The development and effective use of medical language processing technologies is one of today's urgent issues. This paper talks about word vector representation technologies, which are one of the effective technologies used in the organization of searching and semantic analysis of words in electronic text. In particular, the process of determining word vector values according to Word2vec technology is explained.

Keywords: text, word, technology, vector, Word2vec, Ochiai coefficient, GloVe.



Copyright: © 2024 by the authors.

This article is an open access article distributed under the terms and conditions of the Creative Commons Attribution (CC BY) license (<https://creativecommons.org/licenses/by/4.0/>).



Kirish

Hisoblash mashinalari yordamida matnni elektron tarzda saqlash, o'zgartirish va uzatishni amalga oshiruvchi ko'plab vositalar mavjud. Zamonaviy sun'iy intellekt texnologiyalarining, NLP (Natural Language Processing) texnologiyalarining rivojlanishi bilan tabiiy tilga ishlov berish vositalari soni va sifati ham keskin o'sdi[1]. Bunda matn tahlili, so'zlarni tanib olish, guruhlash va ma'no jihatidan tahlil qilish hamda ranjirlashni amalga oshirish uchun so'zni kompyuter tushunadigan tilga o'girish talab etiladi[3]. So'zning barcha xususiyatlarini inobatga olgan holda raqamli ko'rinishning samarali usullaridan biri bu vektorli ifodalashdir. So'zlarni vektorli ifodalashni hozirda keng qo'llanilayotgan texnologiyalardan biri misolida tushuntirishga harakat qilamiz.

Word2vec – so'zlarni vektorli ifodalashning samarali texnologiyalaridan biri bo'lib, u 2013-yilda ishlab chiqilgan. So'zlar bilan ishlashdan tashqari, uning ba'zi kontsepsiyalari tavsiya berish mexanizmlarini ishlab chiqishda va ma'lumotlar ma'nosini ifodalashda, hatto tijoriy, lingvistik bo'lmagan vazifalarda ham samarali qo'llanilib kelinmoqda[6]. Xususan, Airbnb, Alibaba, Spotify va Anghami kabi kompaniyalar ushbu texnologiyadan o'zlarining tavsiya tizimlarida foydalanganlar[2].

Asosiy qism

Ob'ektlarni vektor ko'rinishida tasvirlashni sodda tilde tushuntirish uchun quyidagi misolni ko'rib chiqamiz. Masalan: bir insonni tasvirlash uchun uning bir nechta xususiyatlarini aytish mumkin. Xususiyatlar sonining ortib borishi bilan tasvirlanayotgan shaxs haqida aniqroq tasovvur uyg'ona boshlaydi.

Misol uchun biz tanlagan shaxsni tasvirlash uchun 0 dan 100 gacha bo'lgan shkalada 5 ta xususiyatlarini baholash kerak bo'lsin:

Nº	Xususiyat	Baho (0 da 100 gacha oraliqda)
1.	Hissiyotga beriluvchanlik	38
2.	Kuchli/kuchsiz	76
3.	Sog'lom/xasta	82
4.	Yosh/qari	42
5.	Baland/past	80

1-jadval. Xususiyatlar jadvali

Jadvaldan ko'rinib turibiki tasvirlanayotgan shaxsning hissiyotga beriluvchanlik darajasi 38 ga teng va hk. Hisoblash mashinasida amalga oshiriladigan hisob kitoblarni soddalashtirish uchun qiymatlarni -1 da +1 oralig'idagi shkalaga o'tkazsak quyidagi qiymatlarga ega bo'lamiz:

Shaxs -0,4 0,8 0,8 -0,4 0,8

Tanlangan shaxsga o'xshash bo'lgan shaxsni topish uchun yana 2 ta shaxsning 2 turdagi xususiyatlari berilgan bo'lsin.

Shaxs-1	-0,3	0,2	0,3	-0,4	0,9
Shaxs-2	-0,5	-0,4	-0,2	0,7	-0,1

Berilgan xususiyatlarga ega ikkita shaxsning qaysi biri tanlangan shaxsga ko'proq o'xshashligini aniqlash uchun ularni vektor ko'rinishida ifodalash va taqqoslash mumkin. Quyidagi 1-rasmda ularning vektor ifodasi keltirilgan.

1-rasm. Shaxslar xususiyatlarining vektorli ifodasi

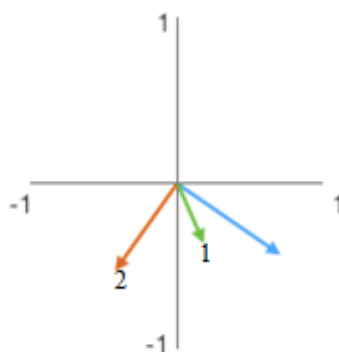

Keltirilgan vektorli ifodadan qaysi bir shaxs tanlangan shaxsga ko'proq o'xshashligi haqida fikr yuritish mumkin. Biroq, hisoblash mashinalarida vektorlar orasidagi o'xshashlik odatda Ochiai koeffitsienti (geometrik koeffitsient) bilan aniqlanadi. Berilgan ikki shaxsning tanlangan shaxsga o'xshashlik darajasini Ochiai koeffitsienti bo'yicha hisoblasak quyidagi natijaga ega bo'lamiz.

$$\text{O'xshashlik} \left(\begin{matrix} -0,4 & 0,8 \end{matrix} \begin{matrix} -0,3 & 0,2 \end{matrix} \right) = 0,87$$

$$\text{O'xshashlik} \left(\begin{matrix} -0,4 & 0,8 \end{matrix} \begin{matrix} -0,5 & -0,4 \end{matrix} \right) = -0,20$$

Natijadan ko'rish mumkinki birinchi shaxs tanlangan shaxsga ko'proq o'xshashlikka ega. Biroq, ko'rilgan misolda faqat 2 ta xususiyat bo'yicha vektor qiymatlarining o'xshashligi hisoblandi. Shaxsning taqqoslash mumkin bo'lgan parametrlari soni ortib borishi bilan vektor qiymatlarining o'xshashligi yanada aniqroq ifodalash mumkin bo'ladi.

Ochiai koeffitsiyenti yapon biologiy Akira Ochiai tomonidan 1957 yilda taklif qilingan ikkilik o'xshashlik o'lchovi bo'lib, keyinchalik biologiyadan tashqarida umumlashtirilgan va turli ilovalarda qo'llanila boshlandi.

Standart ta'rifda ikkita ixtiyoriy A va B to'plamlari uchun koeffitsiyent quyidagicha hisoblanadi:

$$K = \frac{|A \cap B|}{\sqrt{|A| \cdot |B|}} \quad (1)$$



bu yerda, $|A|$ - A to'plamning (mo'ljoni) kardinalligi. Ko'p hollarda Ochiai o'lchovi quyidagi shaklda qo'llaniladi:

$$K = \frac{|A \cap B|^2}{|A| \cdot |B|} \quad (2)$$

Ta'riflovchi to'plamlar uchun Ochiai koeffitsienti quyidagicha hisoblanadi:

$$K = \frac{\sum_{i=1}^r \min(A_i, B_i)}{\sqrt{\sum_{i=1}^r (A_i) \cdot \sum_{i=1}^r (B_i)}} \quad (3)$$

Bunday o'lchov ekologiyada ko'plik namunalari uchun keng qo'llaniladi. Agar ob'ektlar turlarining paydo bo'lishi bilan solishtirilsa, ya'ni $P(A)$ ehtimolliklari - turlar uchraydigan namunalarning nisbiy soni hisobga olinsa, u holda koeffitsient hodisalarning muvofiqligi bo'yicha hisoblanadi:

$$K_{0,0} = \frac{P(A \cap B)}{\sqrt{P(A) \cdot P(B)}} \quad (4)$$

Bundan quyidagi xulosalarni chiqarishimiz mumkin:

Nafaqat odamlar balki boshqa ob'ektlarni raqamli vektorlar sifatida ifodalash mumkin. Vektorlar o'rtasida o'xshashlikni osongina hisoblash mumkin.

Ko'rib chiqilgan xususiyatlarni so'zlarga qo'llash orqali ma'no jihatidan bir biriga yaqin so'zlarni qidirish va ajratib olish mumkin. Buning uchun so'zlarni ma'no jihatida to'liq ifodalangan holda vektor ko'rinishiga o'tkazish talab etiladi. Hozirgi kunda so'zlarni vektor ko'rinishida ifodalovchi bir qator texnologiyalar va dasturlash kutubxonalarini mavjud. Ularga quyidagilarni misol qilish mumkin:

- Word2vec;
- GloVe;
- CBOW;
- SkipGram;
- FastText.

Bunday texnologiyalar hisoblash mashinalarida so'zlarni ma'no jihatidan barcha xususiyatlarini ifodalovchi qiymatlarni umumlashtiruvchi vektor ko'rinishida ifodalash uchun qo'llaniladi.

Xulosa

Xulosa sifatida shuni aytish mumkinki, so'zning vektor shaklini hosil qilish uchun uning shakli va ma'no jihatidan kuzatilishi mumkin bo'lgan barcha xususiyatlari inobatga olishi zarur. Shunda, vektor qiymatlari o'zaro yaqin bo'lgan so'zlar ma'no jihatidan ham bir biriga yaqin so'zlar bo'ladi. Hozirda ko'plab tizimlarda qidirish, guruhlash va bashorat qilish algoritmlarini ishlab chiqishda ushbu yondashuv keng qo'llanilmoqda. o'zbek tilidagi so'zlarning ham shunday vektor korpusini ishlab chiqish kompyuter lingvistikasi va Tabiiy tilni qayta ishlash sohasidagi ko'plab muammolarga yechim topish imkoniyatini yaratadi.



Authors

Elmurod Urinov

Department of Communication and Digital Technologies, "University of Management and Future Technologies" universiteti,

Tashkent, 100208, Uzbekiston;

Nurbek Kholmurodov

Department of Communication and Digital Technologies, "University of Management and Future Technologies" universiteti,

Tashkent, 100208, Uzbekiston;

Correspondence: u.elmurod1988@gmail.com;

A COMPARATIVE ANALYSIS OF TRADITIONAL AND DEEP LEARNING-BASED APPROACHES FOR FACE DETECTION: PERFORMANCE, ADVANCEMENTS, AND CHALLENGES

Abstract: This thesis presents a comprehensive survey and analysis of various neural network architectures utilized in the domain of face detection, focusing specifically on their effectiveness in handling occlusion. The research investigates the challenges posed by occlusion in face detection and examines state-of-the-art neural network models designed to address this issue. The study explores the strengths, limitations, and advancements made in these architectures concerning occlusion handling.

Keyword: Face detection, traditional approaches, deep learning, Viola-Jones, CNN,



Copyright: © 2024 by the authors.

This article is an open access article distributed under the terms and conditions of the Creative Commons Attribution (CC BY) license (<https://creativecommons.org/licenses/by/4.0/>).



Introduction

Face detection, a pivotal component of computer vision technology, plays a fundamental role in identifying and localizing human faces within images or video frames. Its ubiquitous relevance spans across diverse domains such as security surveillance, entertainment applications, healthcare diagnostics, personalized marketing, and human-computer interaction. While the significance of accurate face detection cannot be overstated in these realms, the efficacy of this technology encounters numerous hurdles, especially in scenarios where faces are partially obscured or occluded.

The evolution of face detection algorithms has significantly enhanced the precision and efficiency of identifying faces in varying environmental conditions and contexts. Despite these advancements, the detection of faces under occlusion remains a persistent challenge, impeding the technology's reliability in real-world applications. Occlusion, stemming from varied factors like objects, hands, facial accessories, or even natural facial expressions, poses a substantial obstacle to accurate face detection. Addressing occlusion in face detection is imperative for the technology's robustness and practical utility across domains. Overcoming occlusion demands the development and deployment of sophisticated algorithms and neural network architectures capable of discerning and reconstructing obscured or partially visible facial features.

This survey paper endeavors to comprehensively explore the landscape of face detection under occlusion. It aims to analyze and evaluate a spectrum of neural network architectures and methodologies specifically designed to mitigate the challenges posed by occlusion. By synthesizing existing research and advancements, this paper aims to provide insights into the strengths, limitations, and future directions in the quest for more effective face detection under occlusion.

Exploring Face Detection Techniques

2.1 Traditional approaches

The Viola-Jones algorithm, pioneered by Paul Viola and Michael Jones, stands out for its adeptness in object detection [1]. It functions through the utilization of Haar-like features, which are rectangular filters designed to detect pixel intensity variations across various sections of an image. These features collectively form a potent classifier capable of efficiently distinguishing between facial and non-facial elements. Employing a cascade of classifiers, the algorithm strategically narrows down regions likely to contain faces, thus notably decreasing computation time.

The HOG (histogram oriented gradient) algorithm, developed by Navneet Dalal and Bill Triggs, relies on the distribution of gradient orientations in localized regions of an image. It computes histograms of gradient orientations, which are representations of the local edge directions, and then creates a descriptor capturing the distribution of these gradients. HOG is robust to changes in illumination and background clutter, making it effective for face detection [2].

Each of these traditional algorithms has its strengths. Viola-Jones is known for its speed, HOG for its robustness against variations in lighting and background, and Haar-like features for their simplicity and effectiveness in identifying distinctive patterns in an image. However, they also have limitations. Viola-Jones can sometimes struggle with pose variations and complex backgrounds. HOG, while robust, might not perform as well with extreme variations in facial expressions or occlusions. Haar-like features might oversimplify certain facial characteristics, limiting their accuracy in complex scenarios.

These traditional techniques laid the groundwork for more advanced and robust face detection methods by providing insights into feature extraction and classification. Modern approaches often integrate deep learning models, leveraging convolutional neural networks (CNNs) and other sophisticated architectures to achieve higher accuracy and adaptability in various conditions.

2.2 Neural networks based approaches

Multi-Scale Fully Convolutional Network (MS-CNN). This is a specialized neural network architecture tailored for precise face detection across multiple scales within an image canvas. This architecture's core strength lies in its ability to handle faces appearing at various sizes and resolutions. By employing a fully convolutional structure, the MS-CNN operates on different scales of the input image, allowing it to detect faces at varying sizes simultaneously. This network architecture is designed to extract hierarchical features from different layers, capturing facial characteristics at multiple levels of abstraction. This comprehensive feature extraction process enables the network to discern faces amidst diverse scales and complexities. Notably, the MS-CNN integrates contextual information from these varied scales, improving its accuracy even in scenarios involving cluttered backgrounds or occlusions that might obscure parts of the face [3].

Typically leveraging an anchor-based approach, the MS-CNN predicts bounding boxes at different scales and aspect ratios across the image, aiding in precisely localizing potential face regions. During training, the network learns to optimize its parameters by minimizing the disparity between predicted bounding boxes and annotated face locations within labeled datasets. MS-CNN has demonstrated promising performance in face detection tasks, exhibiting high accuracy across various benchmarks. Its multi-scale approach addresses the challenge of identifying faces regardless of their sizes or orientations, making it suitable for real-world applications where faces exhibit diverse perspectives and appearances. This architecture represents a significant stride in advancing the accuracy, efficiency, and adaptability of face detection models under varied conditions.

Face Detection Algorithm Based on Double-Channel CNN. In literature [4] proposed a model architecture based on VGGNet and residual network. The main reason for choosing VGGNet in this paper is its excellent performance in image feature extraction, and it is easy to modify and train. Residual network is used because it is easy to optimize and can extract face features well with a simple modification. The overall framework of the model is shown in Figure 1. The occlusion perceptron network is used to extract facial features in fewer occlusion regions. The main function of the Region Decision Unit (RD-Unit) is to determine whether the occlusion ratio of the subregion exceeds the set value. When the occlusion of a certain area exceeds the set proportion, the feature vector of the area is discarded. Several regional occlusion judgment units are integrated into the VGG16 network to screen out the subregions with less occlusion. Therefore, the occlusion perceptron network can extract the face related features in fewer occlusion areas. Residual neural network (RNN) is applied to extract full-face features. The output of the two networks is fused with feature vectors by the single-factor weighting method, and the fused feature vectors will be used for face detection.

Multi-task Cascaded Convolutional Networks (MTCNN) is a popular deep learning-based algorithm used for face detection. It's a multi-stage framework designed to detect faces in images while handling variations in pose, scale, and lighting conditions. MTCNN consists of three stages, each focusing on a specific aspect of face detection [5]:

Stage 1: Proposal Network (P-Net). In this stage generates candidate facial regions likely to contain faces. It employs a fully convolutional network to scan the image at multiple scales, detecting faces of different sizes. Utilizes a sliding window technique to propose candidate bounding boxes with associated probabilities for face regions. Works efficiently in identifying potential face locations but might produce false positives;

Stage 2: Refinement Network (R-Net). In this stage refines the candidate face regions obtained from the first stage. Filters out false positives by performing more precise bounding box regression. Evaluates the proposed regions, discarding inaccurate regions and further narrowing down potential face regions. Improves the accuracy of face localization by refining the bounding boxes;



Stage 3: Output Network (O-Net). The final stage performs further refinement and detailed facial feature extraction. Detects facial landmarks (such as eyes, nose, and mouth) within the bounding boxes identified by the previous stages. Outputs the final bounding boxes for faces along with the precise facial landmarks.

MTCNN is widely used in applications requiring accurate and robust face detection, such as facial recognition systems, surveillance, and biometric authentication. However, the choice of a face detection algorithm depends on factors like accuracy, speed, and resource constraints specific to the intended application.

Conclusion

In the domain of face detection, traditional methods like Viola-Jones and Histogram of Oriented Gradients (HOG) offer simplicity and speed but struggle with handling diverse conditions. Contrastingly, neural network-based algorithms such as Multi-Stage Cascaded Convolutional Networks (MTCNN), Double-Channel CNN, and Multi-Scale Convolutional Neural Network (MS-CNN) provide robustness and accuracy, leveraging deep learning techniques to address variations in scale, pose, and lighting. However, their effectiveness often comes at the cost of computational intensity and the need for substantial labeled datasets for training. Each approach presents a trade-off between speed, accuracy, and resource requirements, catering to specific application needs within face detection tasks.

References

1. Viola, P.; Jones, M. (2001). "Rapid object detection using a boosted cascade of simple features". Proceedings of the 2001 IEEE Computer Society Conference on Computer Vision and Pattern Recognition. CVPR 2001. Vol. 1. IEEE Comput. Soc.
2. William T. Freeman, Michal Roth, "Orientation Histograms for Hand Gesture Recognition", Tech. Rep. TR94-03, Mitsubishi Electric Research Laboratories, Cambridge, MA, December 1994.
3. S. R. Dubey, "Local directional relation pattern for unconstrained and robust face retrieval," *Multimedia Tools and Applications*, vol. 78, no. 19, pp. 28063–28088, 2019.
4. H. Li, Z. Lin, X. Shen, J. Brandt and G. Hua, "A convolutional neural network cascade for face detection," 2015 IEEE Conference on Computer Vision and Pattern Recognition (CVPR), Boston, MA, USA, 2015, pp. 5325-5334, doi: 10.1109/CVPR.2015.7299170.
5. J. Xiang and G. Zhu, "Joint Face Detection and Facial Expression Recognition with MTCNN," 2017 4th International Conference on Information Science and Control Engineering (ICISCE), Changsha, China, 2017, pp. 424-427, doi: 10.1109/ICISCE.2017.95.



Mualliflar

Farrux Axmedov

Kommunikatsiya va raqamli texnologiyalar kafedrası, "University of Management and Future Technologies" universiteti,

Toshkent, 100208, O'zbekiston;

Muhriddin Umarov

Kommunikatsiya va raqamli texnologiyalar kafedrası, "University of Management and Future Technologies" universiteti,

Toshkent, 100208, O'zbekiston;

Mas'ul: axmedovfarrux@336gmail.com

O'ZBEKCHA MATNDAN NUTQ SIZTEZLASH DASTURIY TIZIMI UCHUN DIFONLAR BAZASININING QURILISHI

Annotatsiya: Mazkur ishda o'zbekcha matndan nutq sintez qilish dasturi uchun kiritilgan matnni tahlil qilish, fonetik qoidalar asosida difonli bo'lakarga ajratish va ushbu bo'laklar uchun ma'lumotlar bazasini shakllantirish tamoyillari ko'rib chiqiladi.

Kalit so'zlar: matn, nutq, sintezlash, difon, baza, unli, undosh.



Copyright: © 2024 by the authors.

Ushbu maqola Creative Commons Attribution (CC BY) litsenziyasi shartlari asosida tarqatiladigan ochiq foydalanish maqolasi hisoblanadi (<https://creativecommons.org/licenses/by/4.0/>).



CONSTRUCTION OF A DIPHONE BASE FOR A UZBEKI TEXT-TO-SPEECH SOFTWARE SYSTEM

Abstract: In this work, the principles of analyzing the text entered for the Uzbek text-to-speech synthesis program, dividing it into diphonic fragments based on phonetic rules, and forming a database for these fragments are considered.

Keywords: text, speech, synthesis, diphone, base, vowel, consonant.



Authors

Farrukh Akhmedov

Department of Communication and Digital Technologies, University of Management and Future Technologies, Tashkent, 100208, Uzbekistan;

Muhriddin Umarov

Department of Communication and Digital Technologies, University of Management and Future Technologies, Tashkent, 100208, Uzbekistan;

Correspondence:
akhmedovfarrukh@336gmail.com



Copyright: © 2024 by the authors.

This article is an open access article distributed under the terms and conditions of the Creative Commons Attribution (CC BY) license (<https://creativecommons.org/licenses/by/4.0/>).

Kirish

Matndan nutq sintezlash (MNS) tizimi – bu berilgan matnni nutq tovushlariga o‘tkazish tizimidir. Bunda matn manbaasi turlicha bo‘lishi mumkin. Shu o‘rinda MNS tizimi matnni qayta ishlash va nutq yaratish qismlarini o‘z ichiga qamrab olgan tizimdir. Ideal MNS tizim deganda inson nutqini aniq va to‘liq talaffuz eta oluvchi tizim tushuniladi. Misol uchun u raqamlarni va qo‘lyozma matnlarni o‘qiy olishi lozim, so‘zlarni to‘g‘ri talaffuz eta olishi zarur va hokazo.

Matnni tahlil qilish qismi ideal tizimning eng murakkab qismidir, chunki, unda muayyan matnni tushunishga va aniq natija olishga buyurtma beriladi, matn esa o‘ta aniqlikda grammatik tahlil qilinadi. Matnni tahlil qilish qismining asosiy vazifasi – kiritiluvchi matnni nutq hosil qilish qismiga yuborish uchun “kichik qismlar”ga ajratishdir. Matnni tahlil qilish qismining ikkinchi vazifasi – so‘z va gapdagi talaffuzni aniqlashdir. Bunda ma‘lumot nutq hosil qilish qismiga u tushunadigan formatda yuboriladi. Matn tahlili qismining bunday vazifalari ko‘p jihatdan MNS tizimining sifat darajasini belgilab beradi.

Matnni qayta ishlash. Ushbu tizimning matnni qayta ishlovchi qismi dastlab, berilgan matnni so‘zlarga, so‘ngra so‘zlarni difon deb ataluvchi bo‘laklarga ajratadi. Difon – so‘zning ikki yoki uch harfidan iborat nutqiy bo‘lagi bo‘lib, u tizimning nutqni sintez qilish qismi tomonidan qabul qilinadi va qayta ishlanadi. Tizimning nutqni qayta ishlash qismi to‘g‘ri va aniq ishlashi uchun so‘zlar mumkin qadar jarangli (unli harf qatnashgan) bo‘laklarga bo‘linishi kerak. Agar bunday bo‘laklashni uch hafrdan iborat chegarani saqlagan holda bajarib bo‘lmasa (ya‘ni, ketma-ket undosh harflar kelsa), u holda jarangsiz qismlarda ham bo‘laklash amalga oshiriladi.

Asosiy qism

Nutq hosil qilish qismining vazifasi – tovushni imkon qadar moslashtirib, tovush chiqarish qurilmasiga uzatishdan iborat. Agar harflar soni limitdan oshib ketsa, u holda jarangsiz bo‘lakchalarda ham bo‘laklanish amalga oshiriladi. Jarangli qismlarni birlashtirish uchun PSOLA algoritmidan foydalaniladi. Jarangsiz qismlar esa bevosita, to‘g‘ridan-to‘g‘ri birlashtiriladi. Agar unli harf ikkita undosh harflar o‘rtasida kelsa, u holda bu unli harf har ikkala difonga qo‘shiladi. Masalan, “fan” so‘zi “fa” va “an” kabi bo‘linadi. Bu yerda “a” harfi har ikkala difonga kiritilgan. Lekin bunday bo‘laklashni jarangsiz qismlar uchun ishlatib bo‘lmaydi. Ideal holatda barcha bo‘laklar jarangli bo‘lishi kerak. Biroq, bo‘laklardagi harflar sonining 4-5 tadan oshib ketishi muammo tug‘diradi. Masalan, “shartli” so‘zi quyidagicha bo‘laklarga bo‘linishi kerak: “sha” va “artli”. Ushbu birikmaning 2-bo‘lagidagi harflar soni 5 ta. Bunday vaziyatda ikkinchi bo‘lak harflari ikki bo‘lakka ajratiladi. Jarangsiz qismlar odatda, nutqning turg‘un qismi bo‘lib, ularni birlashtirishda sifati deyarli pasaymaydi. Tizimda so‘zlarning bo‘laklarga bo‘lib olinishini ushbu jadval orqali yaxshiroq tushunib olish mumkin.

1-jadval. Tizimda so‘zlarning bo‘laklarga bo‘lib olinishini.

KIRITISH	CHIQRISH
Dastur	Da-astu-ur
Samara	Sa-ama-ara
Tuzilma	Tu-uzi-il-ma
Saroy	Sa-aro-oy
Soat	So-at
Birlashma	bi-ir-la-ash-ma

Kiritiluvchi matn faqat harflar va sonlardan tashkil topgan bo‘lishi lozim. Sonlar tizimda so‘zlarga aylantiriladi. Tizim tinish belgilarini tushirib qoldiradi hamda tizimda aniq vaqt belgilanmaydi.



Ma'lumotlar bazasining shakllantirilishi. Ma'lumotlar bazasini shakllantirish – MNS tizimining eng zaruriy qismlaridan biri bo'lib, undan nutq sintez qilish qismida mos tovush fayllarini olish uchun foydalaniladi. Birlashyitishlarda qo'llaniluvchi difonli bo'lakchalarning tovush fayllari tizim ishga tushmasidan avval, ma'lumotlar bazasiga joylashtirilgan bo'lishi lozim. Ulardan nutq sintezi qismida nutqni moslashtirish jarayonida foydalaniladi.

Kiritilgan matndan ajratib olingan bo'laklar uchun mos difonlarni ma'lumotlar bazasidan olish mumkin. Matndan yoki to'liq so'zdan difon olish, yaxshi talaffuzli nutq hosil qilishda tayyor difonlardan foydalanishdan ko'ra yaxshiroq sifat ko'rsatkichini beradi. Matn yoki so'z kiritishni hal qilish muhim bosqich. Bir qancha mulohazalardan so'ng shu narsa ma'lum bo'ldiki, yangi yozilgan ibora ma'lumotlar bazasiga ko'pgina difonlarni qo'shadi. Bunda, difonlarning aksariyat qismi oldindan yozib qo'yilgan bo'ladi. Shunga qaramasdan, yozilgan difonlar soni unga mos difonlar sonining 10% ini tashkil etadi. Shuning uchun biz difon olishning yaxshiroq yo'lini topishimiz lozim. Maqsad – bazaga yangi difon kiritmasdan, so'zlar ustida ishlashga ko'p vaqt sarflamaslik uchun mumkin qadar kamroq so'zlarni yozishdir. Kiritilgan so'zlarda mumkin qadar takrorlanuvchi difonlar soniga mos holda yozilgan so'zlar soni qisqartiriladi. Kiritilgan matnda buni bajarish juda qiyin bo'lganligi sababli dasturda shu ishni bajaruvchi qism dastur kritiladi. Dastur matndagi barcha so'zlar ro'yxatini tuzadi va ularga mos bo'lgan difonlar sonini hisoblaydi, so'ngra, bu so'zlardan olingan difonlarni ro'yxatga oladi va ro'yxatda yo'q bo'lgan difonlar sonini barcha so'zlardan tekshirib chiqadi. Eng ko'p difonlarni qabul qilgan so'z olinadi va yana jarayon shu tarzda davom etadi. Jarayon barcha so'zlarda yangi difonlar yo'qolgunga qadar davom etadi. Biroq, so'zlar soni oshib ketganda operatsiyani bajarish uchun juda ko'p vaqt talab etiladi. Ushbu muammoni hal etish uchun boshqacharoq yo'sinda yondoshish kerak. Yaratilgan so'zlar ro'yxatidagi harflar soni 16 tadan ko'p bo'lgan so'zlarning ixchamroq ro'yxati yasaladi. Jarayon bu ro'yxatda qisqa vaqt ichida bajariladi. Agar barcha difonlarni olish imkoni bo'lmasa, limit qisqartiriladi va jarayon yana davom ettiriladi. Ushbu metodlardan foydalanib, kiritilgan matn yoziladi.

Tovush ohangi so'zning turli joyida turlicha eshinishi mumkin. So'z tarkibidan olingan tovush – shunga o'xshash boshqa qismdan olingan tovush bilan birgalikda kelishi nuqtayi nazaridan, ba'zi o'zgarishlar bo'lish ehtimolligi oshadi, chunki, fonemalar bo'yicha harakatlanadi. Shuning uchun, yaxshiroq nutq yasash maqsadida, so'zning turli qismlari uchun turli difonlar faylga yozilgan bo'lishi kerak. Bu qismlarni uchga bo'lish mumkin: boshlang'ich qism, o'rta qism va so'ngi qismlar. Ushbu qismlar uchun turli difonlarni yozib olinadi va ulardan mos ravishda foydalaniladi. Bunda so'z yasashda so'zning birinchi qismi uchun ajratib olingan difon o'rta qismi yoki so'ngi qismida ishlatilmaydi. Masalan, agar "da" difoni "daftar" so'zidan olib yozilgan bo'lsa, u "oldida" sintezida qo'llanilmaydi. Mazkur tamoyil asosida, difonlar va harflarni farqlash tamoyili ishlab chiqildi. Unga ko'ra agar "a" harfi so'z oxirida kelsa, tizim difonlarni o'qishda "a" dan keyin "_" belgisini qo'yib ajratadi. Masalan, "no" difoni "nomli" so'zidan ajratib olingan bo'lsa, u "nomli" so'zining boshlang'ich qismida kelganligi uchun "no_b" (boshlang'ich) kabi yoziladi, agar "no" difoni "asnoda" so'zidan ajratib olingan bo'lsa, "no" so'zning o'rtasida kelganligi uchun "no_o" kabi yoziladi va agar, "no" difoni "istisno" so'zidan ajratib olingan bo'lsa, "no" so'zning so'ngida kelganligi bo'is "no_s" kabi yoziladi. Har bir difon o'zining o'ng va chap taraflarining har ikkalasi uchun tebranish qiymatlariga ega. Agar chap yoki o'ng tomon jarangsiz bo'lsa, u holda, bu qism bo'yicha tebranish qiymati 0 (nol)ga keltiriladi. Masalan, hosil qilingan ma'lumotlar bazasida "ka_b" bo'yicha tebranish qiymati chap tomon uchun 0 ga va o'ng tomon uchun 147 ga teng; "ara_o" uchun tebranish qiymati chap tomon uchun 142 ga va o'ng tomon uchun 145 ga teng. Real vaqtda bu qiymatlardan biri hisoblanishi kerak yoki birgalikda hisoblanib, ishga tushiriladi. Tizim ishlayotgan jarayonda buni avtomatik tarzda bajarish qiyin bo'lganligi sababli, uni ma'lumotlar bazasini shakllantirish vaqtida hisoblagan ma'qul. Yuqoridagi fikr mulohazalardan kelib chiqib, difonli ma'lumotlar bazasini shakllantirishda quyidagicha maydonlarning mavjudligi hisobga olinishi lozim:

2-jadval. Difonli ma'lumotlar bazasining ma'lumot maydonlari

T r	Boshlan- g'ich difon	O'rt a difo n	So'ng i difon	Tebrani sh qiy mati chap tomon	Tebrani sh qiy mati o'ng tomon	Boshlang'ich diapazon	So'nggi diapazon
1.	aa_b	aa_o	aa_s	142/139/14 1	143/139/13 8	1579/2217/10861	1603/2345/11005
2.	ab_b	ab_o	ab_s	147/146/14 3	53/60/35	5643/4621/9870	5712/4788/9948
3.	eki_b	eki_o	eki_s	151/153/14 8	106/108/10 5	15480/19924/648 3	15596/20056/657 8

Ushbu jadval misol sifatida keltirilgan. Undagi “Boshlang'ich diapazon” hamda “So'nggi diapazon” deb nomlangan maydonlarda mazkur difonli bo'lakchani oldindan yozib olingan nutq fayli tarkibidagi boshlang'ich va so'nggi nuqtalardagi diapazon qiymati. Bu ustundagi qiymatlar difonning boshlang'ich, o'rt va so'nggi qismlari uchun slesh (“/”) belgisi bilan ajratib ko'rsatilgan. Ma'lumotlar bazasini shakllantirishda, dasturlash jarayoni hamda dasturning bajarilish jarayonlaridagi ortiqcha hisoblashlarning oldini olish maqsadida, ularni alohida maydonlarda kiritish kerak bo'ladi.

Xulosa

Matndan nutq sintezlashning keng ommalashgan usullaridan biri – konkatenativ sintezlash uslubidir. Bunda difonli bo'laklarning bog'lanishi asosida yangi nutqning sintezlanishi tamoyili qo'llaniladi. Ishda o'zbekcha matndan nutq sintez qilish dasturi uchun kiritilgan matnni tahlil qilish, fonetik qoidalar asosida difonli bo'laklarga ajratish va ushbu bo'laklar uchun ma'lumotlar bazasini shakllantirish masalalari ko'rib chiqildi. Bunda difonlar bazasini shakllantirish va bu bosqichda o'zbekcha matnlar uchun yuzaga keluvchi ba'zi muammolar va ularning yechimlari xususida fikrlar yoritildi.

Adabiyotlar

1. Allen J., Hunnicutt S., Klatt D. From Text to Speech: The MITalk System. Cambridge University Press, Inc.
2. Taylor P. – “Text-To-Speech-Synthesis”, University of Cambridge, 2007.
3. Б. М. Лобанов, Л. И. Цирульник «Компьютерный синтез и клонирование речи». — Минск, «Белорусская Наука», 2008. — 316 стр.
4. B.Bahriddinova, “Hozirgi o'zbek tili fonetika-fonologiyasi” – ma'ruzalar matni, Qarshi Davlat Universiteti, 2007-y.



NUTQNI TANIB OLISHNI AMALGA OSHIRISH BOSQICHLARI

Annotatsiya: Ushbu maqolada nutq signalini tanib olishning sohalarga tadbirlari, buyruqlarni tanib olish bosqichlari, nutq signalini tahlil qilish algoritmlari, ularda qo'llaniladigan uslublar va yondashuvlar yoritib berilgan.

Kalit so'zlar: nutqni tanish, Smart House, IoT (Internet buyumlari), formant chastota, fragment, spektral tahlil, xususiyatlarni ajratib olish, kNN, SVM, Markov zanjiri, akustik ishlov berish, ovoz modeli, filtrlash.



Muallif

O'rinboy Naziraliyev

Kommunikatsiya va raqamli texnologiyalar kafedrasida, "University of Management and Future Technologies" universiteti, Toshkent, 100208, O'zbekiston;

naziraliyevurinboy1996@gmail.com



Copyright: © 2024 by the authors.

Ushbu maqola Creative Commons Attribution (CC BY) litsenziyasi shartlari asosida tarqatiladigan ochiq foydalanish maqolasi hisoblanadi (<https://creativecommons.org/licenses/by/4.0/>).



Author

Urinboy Naziraliyev

Department of Communication
and Digital Technologies,
University of Management
and Future Technologies,
Tashkent, 100208, Uzbekistan;
naziraliyevurinboy1996@gmail.com

THE MAIN PROCESS TO IMPLEMENT SPEECH RECOGNITION

Abstract: In this article, field applications of speech signal recognition, command recognition steps, speech signal analysis algorithms, methods and approaches used in them are highlighted.

Keywords: speech recognition, Smart House, IoT (Internet of Things), formant frequency, fragment, spectral analysis, feature extraction, kNN, SVM, Markov chain, acoustic processing, sound model, filtering.



Copyright: © 2024 by the authors.

This article is an open access article distributed under the terms and conditions of the Creative Commons Attribution (CC BY) license (<https://creativecommons.org/licenses/by/4.0/>).



Kirish

Nutqni tanish – bu nutq signalini tanib olinishi kerak boʻlgan soʻzlar yoki harflarga aylantirishning statistik jarayonidir. Texnologiya yutuqlarining rivojlanishi bilan nutq soʻzlarini tanish quyidagi sohalarida keng qoʻllanilmoqda:

1. Xavfli xudud va yuqori zararga ega boʻlgan joylarda sanoat dastgohlarini nutq buyruqlari orqali masofadan boshqarish.
2. “Smart House” tizimlarida uy jihozlarini boshqarish, foydalanuvchini aniqlash va nazorat qilish.
3. Transport vositalarini boshqarishda – shtat va bort tizimlarini ovozli boshqarish (multimedia tizimlari, navigatsiya qurilmalari, bort kompyuterlari va h.k.).
4. IoT (ing. Internet of things) texnologiyalarini amalga oshirishda – masofadan boshqarish va identifikatsiya qilishda.
5. Imkoniyati cheklangan insonlar uchun interfeys – buyruqlarni bajarish, ovozli boshqarish, ovozli assistent, nutqni matnga oʻgirish.
6. Xizmat koʻrsatish sohalarida – infokioskalarda maʼlumot olish, “Call Center” larda avtomatik javob berish, mijozlar xohishlarini oʻrganish tizimlari.

Kundan kunga real vaqtda nutqni tanib olish va tahlil qilish tizimlarga talab ortib bormoqda. Bunday real vaqt tizimlari orqali katta maʼlumotlar bazasi talablari, nutq signallarining shovqinga taʼsirchanligi va yuqori hisoblash resurslari talablari boʻlganligi uchun oʻrnatilgan apparat-dasturiy platformada boshqarish qiyin. Qayta dasturlanuvchi integral sxemalar (ing. Field Programmable Gate Array) va maxsus mobil protsessorlarga asoslangan apparat-dasturiy platformalar bunday real vaqt tizimlarining samarasani oshiradi va nutq buyruqlarini tanib olish imkoniyati beradi. Bunday platformalar oson dasturlash imkoniyati va yuqori hisoblash samaradorligiga ega ekanligi bilan nutq signallariga ishlov berishda munosib platforma hisoblanishi mumkin.

Nutq signali – bu murakkab dinamik jarayonning modeli boʻlib, uni tahlil qilishda signal va uning fragment qismini tavsiflovchi bir nechta koʻrsatkich (xususiyatlar)lariga tayaniladi. Nutq signallarining ushbu asosiy xususiyalari quyidagilar: formant chastotasi, asosiy ton chastotasi, spektral tashkil etuvchilardir.

Asosiy qism

Tahlil qilish uchun nuqt signalining eng sodda koʻrinishi, bu ajratib olingan soʻzlardir. Odatda soʻzlar va ularning lugʻatlari cheklangan boʻladi. Zamonaviy murakkab nutqni tanish tizimlarida ham asosan oʻzak soʻzlarni ajratib olish orqali amalga oshiriladi. Nutq buyruqlari orqali boshqarish tizimlarida esa juda ham qoʻl keladi.

Roman-german oilasiga mansub va baʼzi bir osiyo tillar uchun nutqni tanib olish algoritmlari va modellari ishlab chiqilgan. Lekin, ushbu tillar uchun ishlab chiqilgan model va algoritmlar “oʻzbek tili” uchun toʻgʻri kelmaydi. Bundan tashqari ularni apparat-dasturiy vositalarida amalga oshirish hozirgi kunda ham aktual hisoblanib, maxsus yondashuvlarni talab etadi.

Nutqni avtomatik tanib olish tizimlari quyidagi bosqichlarda amalga oshiriladi (1-rasm): xususiyatlarni ajratib olish, oʻqitish va tanib olish.

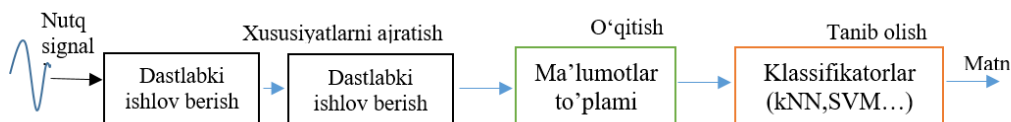

1-rasm. Nutq tanib olishni amalga oshirish bosqichlari

Dastlabki ishlov berish – signalni qabul qilish, analogdan raqamli ko‘rinishga o‘zgartirish, filtrlashdan iborat.

Xususiyatlarni ajratish – jimlik so‘halarini olib tashlash, oynalardan o‘tqazish, spektr qiymatlarini va MFCC(ing. Mel Frequency Cepstral Coefficient - Mel chastotaviy keprstral koefitsienti) parametrlarini hisoblashni tashkil etadi.

o‘qitish va tanib olish – bunda har bir nutq so‘zi olingan parametralari bo‘yicha mashinali o‘qitish va sun‘iy intellekt algoritmlari orqali o‘qitiladi va tanib olinadi.

Nutqni avtomatik tanib olishning eng muvaffaqiyatlilari ajratilgan so‘zlarni tanib olish uchun suxandonga sozlangan tizimlar bo‘lib chiqdi. Bunday tizimlar ikki rejimdan birida ishlaydi. o‘qitish rejimida foydalanuvchi tizimga mikrofondan tanib olish uchun har bir so‘zni aytib, ovozi tanib olishga o‘rgatadi. Tizim har bir so‘zni na‘munasini(etalonini) yaratadi va xotirada saqlaydi.

Tanib olish rejimida har bir aytilgan so‘z yana raqamlashtiriladi va uning na‘muna etaloni xotiradan olingan na‘muna etalonlar bilan taqqoslanadi. Agar mos keladigan bo‘lsa, unda so‘z tanib olinadi va tizim bu haqda foydalanuvchini xabardor qiladi yoki biron bir harakatni amalga oshiradi. Bunday tizimlarning ishlashi suxandonning har bir so‘z oldidan yetarlicha pauza qilishiga, shovqinli fonga va so‘zlarning aniq va to‘g‘ri talaffuz qilinishiga bog‘liq. Tanib olish paytida nutq signallariga raqamli ishlov berishning eng muhim amallari, xususiyatlarni ajratish, og‘zaki nutqlardan alohida namunalar olinib etalonlar yaratish va namunalardan kerakligini tanlab olish, etalonlar xotirada saqlanadigan yozuvlar bilan taqqoslash bajariladi (2-rasm).

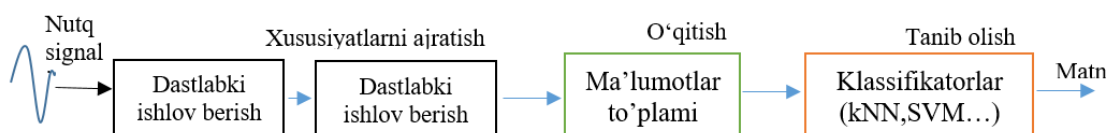

2-rasm. Nuqtni tanib olish tizimining umumiy blok-sxemasi

Nutqni tahlil qilish va xususiyatlarni ajratish bosqichlari quyidagilardan tashkil topishi mumkin:

- akustik;
- fonetik;
- leksik;
- sintaktik;

Nutq signallariga ishlov berishning dastlabki va nisbatan eng sodda darajasi bu akustik va fonetik tahlil bo‘lib, asosan gap bo‘lagini ichidagi alohida ajratilgan so‘zlarni tanib olishga bag‘ishlangan. Nutq buyruq so‘zlarini tanib olishda akustik ishlov berish bosqichini amalga oshirish yetarli hisoblanadi. Keyingi nisbatan murakkab darajasi esa bu leksik, sintaktik va semantik tahlil hisoblanib, qo‘shma murakkab gaplarni tushunishga qaratilgan.

Bajarilgan ilmiy ishlanmalar va eksperimental tadqiqotlarni tahlil qilib qaraydigan bo'lsak, nutqni tahlil qilish va tanib olish usullari va algoritmlari orasida alohida ajartilgan nutqlarga ishlov berishning quyidagi protseduralarini ajratib ko'rsatishimiz mumkin(3-rasm).

Akustik tahlil muhitda tarqalgan akustik axborotni aniqlash, tahlil qilish va tasniflashga qaratilgan usullarni anglatadi. Akustik tahlil qilish avtomatik kuzatuv, aqlli videokonferensiya, inson-kompyuter aloqasi va eshitish apparatlari texnologiyalari kabi bir necha xil ilovalarga ega bo'lgan usullarni o'z ichiga olishi mumkin.

Akustik hodisalarni aniqlash va tasniflash usullari bu tovushlarning vaqt chegaralarini aniqlash va ularni sinf bo'yicha turkumlashga qaratilgan. Akustik tahlilning asosiy muammolaridan biri signallarning nutq faolligi aniqlash, nutqli va nutqsiz sinflarga ajratishdir. Nutq signallarida energiya chegaralari va chastotaning noldan o'tish qiymatlarini aniqlash orqali nutqning aktivligini aniqlash eng soddadir. Bundan tashqari nutq signali aktivligini aniqlashning chuqur o'rganishiga asoslangan usullari keng tarqalgan.

Nutq signallariga dastlabki ishlov berishning bir nechta asosiy algoritmlari mavjud. Ushbu algoritmlarning barchasi, shu jumladan eng murakkablari ham bir xil arifmetik amallarni takrorlaydi. Signallarga dastlabki ishlov berish amallari yuqorida keltirilgan ma'lumotlarni yig'ish(o'qib olish), segmentlash, filtrlash, o'zgartirishlar(almashtirishlar) orqali xususiyatlarini ajratish, tanib olish bosqichlarida amalga oshiriladi. Nutq signallariga ishlov berish barcha asosiy amallari uchun faqat oddiy arifmetik amallar - ko'paytirish, qo'shish, ayirish va o'zgartirish amallarini bajarish talab qilinadi. Svyortka signallarga raqamli ishlov berishda eng ko'p ishlatiladigan amallardan biri bo'lib, raqamli filtrlash asosini tashkil etadi va ko'paytirib jamlash amalidan tashkil topadi.

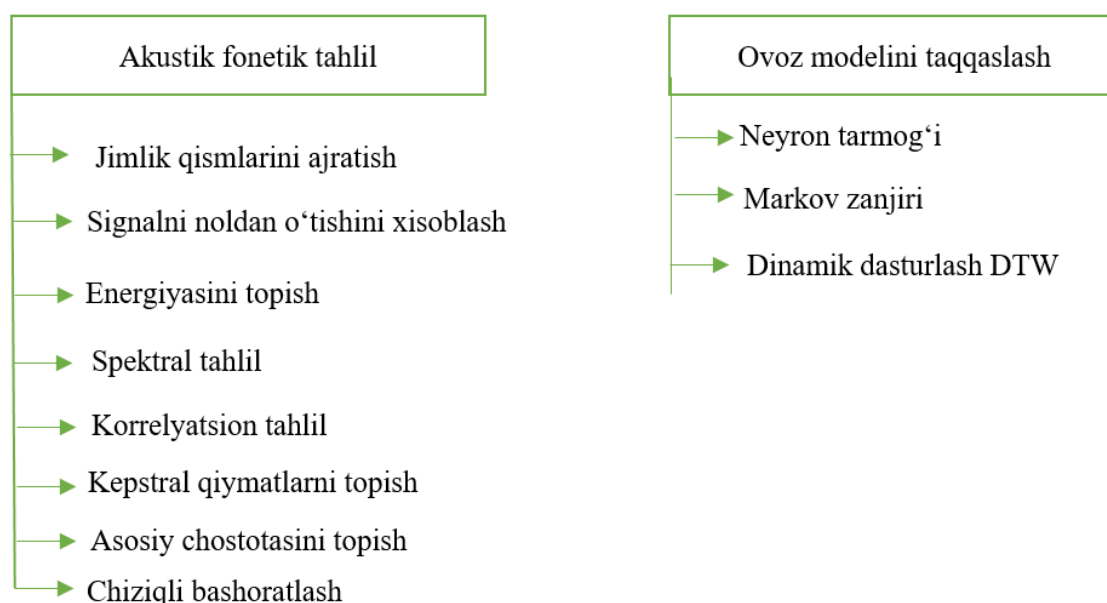

3-rasm. Tahlil qilish usullari.

Filtrlashning maqsadi bu foydali signalda shovqinni yo'qotish yoki kamaytirishdan iborat. Zamonaviy nutq signallariga ishlov berishda va ayniqsa ovoqli boshqaruv tizimlarida real sharoitlarda murakkab filtrlash amallarini talab etadi. Bunday murakkab filtrlash amallarini adaptiv filtrlar, ya'ni ma'lum bir muhitga moslashuvchi filtrlar orqali amalga oshiriladi.

Nutq signallarini tanib olish va uni qurilmaga integratsiya qilish yangi chuqur neyron tahlilga asoslangan yondashuvlarni talab etadi. Bu orqali qisqa lug'atga asoslangan nutq buyruqlarini tanib olishda yuqori natijalarga erishish mumkin.

Adabiyotlar

1. Мусаев М. М., «Современные методы цифровой обработки речевых сигналов.» Вестник ТУИТ, т. 2, № 42, pp. стр. 2-13, 2017.
2. Мусаев М.М., Хужаяров И.Ш., Очилов М.М., «Машинали ўқитиш алгоритмлари асосида ўзбек тили фонемаларини таниб олиш.» Информатика ва энергетика муаммолари., т. 6, 2019.
3. Алимуратов А.К., Чураков П.П., «обзор и классификация методов обработки речевых сигналов в системах распознавания речи.» Измерение. Мониторинг. Управление. Контроль, т. №2, № 12, pp. 27-35, 2015.
4. Musaev M., Khujayorov I. and Ochilov M., «The Use of Neural Networks to Improve the Recognition Accuracy of Explosive and Unvoiced Phonemes in Uzbek Language.» v Information Communication Technologies Conference (ICTC), Nanjing, China, 2020.

INFOKOMMU- NIKATSIYA TARMOQLARDA BUYURTMALARNI TUSHISH VA ULARGA XIZMAT KO'RSATISH JARAYONLARINI MODELLASHTIRISH

Annotatsiya: Maqolada infokommunikatsiya tarmoqlarining tugunlarida axborot oqimining tutilish hamda vaqtini optimallashtirish uchun tasodifiy oqimlarni kutish vaqti, tugunni normal ishlash vaqti va axborotlarning eskirishi noaniq bo'lishini hisobga olgan holda, kutish vaqtini hisoblash modeli yaratilgan. Har qanday texnik tizim tavsiflari va u ishlash samaradorligi loyihalash bosqichidan boshlab aniqlashtiriladi. Ushbu loyihalash usullari va unda ishlatiladigan matematik modellar adekvatligiga kelajakdagi tizimning xossalari va imkoniyatlari bog'liq. Loyihalashdagi hatolar salbiy oqibatlariga va katta iqtisodiy zararga olib kelgan misollarni tahlili keltirilgan.

Kalit so'zlar: Infokommunikatsiya tarmoqlari, trafik, buyurtma taaluqlilik funksiyasi, model, samarali boshqarish, tasodifiy oqimlar.



Mualliflar

A.F.Izbasarov

“Hududiy elektr tarmoqlari” AJ boshqaruv raisining Elektr tarmoqlaridan foydalanish bo'yicha birinchi o'rinbosari, DSc.

Z.Z. Nigmatov

Chirchiq OTQMBY Qo'shinlar kundalik faoliyati va qo'shinlarni boshqarish kafedrasida katta o'qituvchisi, PhD.

A.A.Yaxyoyev

Qurolli Kuchlari Bosh shtabi Aloqa, axborot texnologiyalari va axborotlarni himoyalash bosh boshqarmasi Telekommunikatsiya infratuzilmasini rivojlantirish bo'lim boshlig'i



Copyright: © 2024 by the authors.

Ushbu maqola Creative Commons Attribution (CC BY) litsenziyasi shartlari asosida tarqatiladigan ochiq foydalanish maqolasi hisoblanadi (<https://creativecommons.org/licenses/by/4.0/>).



Authors

A.F. Izbasarov

First Deputy Chairman of the Board of "Territory Electric Networks" JSC for the Use of Electric Networks, DSc.

Z.Z. Nigmatov

Chirchik OTQMBY, senior lecturer of the department of daily activities of troops and management of troops, Ph.D.

A.A. Yakhyoyev

Chief of the Telecommunications Infrastructure Development Department of the General Directorate of Communications, Information Technologies and Information Protection of the General Staff of the Armed Forces

MODELING OF ORDER RECEIVING AND SERVICE PROCESSES IN INFOCOMMUNICATION NETWORKS

Abstract: In the article, a waiting time calculation model was created, taking into account the uncertainty of the waiting time of random flows, the normal working time of the node, and the obsolescence of information, in order to optimize the interception and timing of the information flow in the nodes of information communication networks. Any technical system specifications and its performance are determined from the design stage. The properties and capabilities of the future system depend on the adequacy of these design methods and the mathematical models used in them. An analysis of cases where design errors led to negative consequences and large economic losses is presented.

Keywords: Infocommunication networks, traffic, order relevance function, model, efficient control, random flows.



Copyright: © 2024 by the authors.

This article is an open access article distributed under the terms and conditions of the Creative Commons Attribution (CC BY) license (<https://creativecommons.org/licenses/by/4.0/>).



Kirish

Jahonda harbiy va Davlat telekommunikatsiya tarmoqlarida ko'p pog'onali strukturaga ega bo'lgan tarmoqlar faoliyatini baholash shuningdek ishlash samaradorligini ta'minlash masalasiga katta e'tibor berilmoqda. Ularning ishlash samaradorligini oshirish, mamlakatning ijtimoiy-iqtisodiy rivojlanishini jadallashtirish dasturini hal qilishga yordam beradigan muhim omillardan biri hisoblanadi. Hozirgi vaqtda samarali boshqarishsiz axborot tarmoqlarining normal ishlashi mumkin emas. Birinchi navbatda, bu katta masofalarga tarqalgan harakatdagi obyektlarni boshqarish uchun mo'ljallangan tadqiq qilinayotgan ko'p pog'onali iyerarxik aloqa tarmog'ini o'z ichiga olgan kommutatsiyalanadigan aloqa tarmoqlariga taaluqlidir.

Infokommunikatsiya tarmoqlarni loyihalashning biri - bu maxsus aloqa kanallar o'tkazish imkoniyati, tarmoqlar tugunlarida oqimlarga xizmat ko'rsatish uchun ishlatiladigan buferlar hajmi va boshqa tuzilmaviy elementlarning parametrlarini tanlash. Ko'rsatilgan vazifalarni uchin parametrik sintez usullarini ishlatib amalga oshiriladi. Bugungi kunda ishlatiladigan parametrik sintez usullari oqimlarning klassik matematik modellariga asoslangan, ular o'zini aloqa tarmoqlari kabi kanallarni kommutatsiyalash tarmoqlarni loyihalashda o'zini ijobiy tomondan ko'rsatgan.

Infokommunikatsiya tizimlarda uzatiladigan trafikning zamonaviy tadqiqotlari shuni ko'rsatadi-ki, uning statistik tavsiflari teletrafikning klassik nazariyasida qabul qilingan tavsiflardan farq qiladi. Mustaqil axborot manbalardan kelaytgan oqimlarning katta sonini birlashtirishda Puasson oqimi bilan yoritiladigan jarayonni paydo bo'lishga olib kelishi to'g'ri emas. Bu Puasson modellari va Erlang formulalarga asoslangan infokommunikatsiya tizimlar parametrlarini va ularning ehtimolli-vaqtinchali tavsiflarni hisoblash ananaviy usullarni ishlatish yuklanishni yetarlicha bahola olmaslikka olib keladigan asoslanmagan optimistli natijalarni chiqarib beradi.

Asosiy qism

Infokommunikatsiya tarmoqlardagi axborot oqimlarning xossalarning ohirgi tadqiqotlari shuni ko'rsatdi-ki, o'ziga o'xshashli jarayonlar modellarini ishlatish bu tizimlardagi uzatilayotgan trafikni aniqroq yoritish imkonitini beradi.

O'ziga o'xshashli jarayonlarga amodellarni ishlatishga asoslangan xizmat sifati umumtizimli parametrlarini ta'minlovchi t infokommunikatsiya tizimning parametrik sintezi vazifalarga bag'ishlangan taqdiqotlar to'g'risida ma'lumotlar juda kam. Bu maqolada, oldin o'tkazilgan o'ziga o'xshash oqimlar taqdiqotlarga asoslangan holda oqimlar matematik modellari tanlangan va infokommunikatsiya tarmoqning turli qismlarida oqimlar parametrlarini aniqlash usullari taklif etilgan.

Infokommunikatsiya tarmoqlardagi axborot oqimlarning vaqt bo'yicha taqsimlangan hodisalar yig'indisi oqim deb ataladi. Agar hodisa buyurtmalarining paydo bo'lishi bilan ifodalansa, buyurtmalar oqimi deyishimiz mumkin. Buyurtmalar oqimini tavsiflash uchun, umumiy holatda, $(k-1)$ va k ga mos tartib raqami bilan tushayotgan buyurtmalar t_{k-1} va t_k qo'shni momentlari orasidagi $\tau_k = t_k - t_{k-1}$ vaqt intervalini berish zarur. Infokommunikatsiya tarmoqlardagi buyurtmalar oqimining asosiy xarakteristikasi uning intensivligi λ hisoblanadi va vaqt birligida bir qancha chegaralardan o'tuvchi buyurtmalarining o'rtacha sonini bildiradi. $\alpha = 1/\lambda$ kattaligi ikki ketma-ket buyurtmalar orasidagi o'rtacha vaqt intervalini aniqlaydi.

τ_k ketma-ket buyurtmalar orasidagi vaqt intervali oldindan aniq bo'lgan qiymatni qabul qilsa, bunday oqim determinirlangan oqim deyiladi. Bunda agar intervallar bir hil bo'lsa (barcha $k=1,2 \dots$

uchun $\tau_\kappa = \tau$) bu oqim muntazam oqim deyiladi. Muntazam oqim buyurtmalarini to'la tavsiflash uchun oqim intensivligi λ yoki interval kattaligi $\tau = 1/\lambda$ ni berish yetarli. Ketma-ket buyurtmalar orasidagi vaqt intervali τ_κ tasodifiy kattalikni bildirsa, bunday oqim tasodifiy oqim deyiladi. Tasodifiy oqim buyurtmalarini to'la tavsiflash uchun odatda barcha intervallar τ_κ ($\kappa = 1, 2, \dots$) uchun taqsimot qonuni $A_\kappa(\tau_\kappa)$ ni berish zarur.

Infokommunikatsiya tarmoqlardagi buyurtmalar orasidagi barcha intervallar τ_1, τ_2, \dots bo'lgan tasodifiy oqim bir-biriga bog'liq emas va $A_1(\tau_1), A_2(\tau_2), \dots$ taqsimot funksiyalari bilan berilsa, bu oqim cheklangan oqim deyiladi.

Barcha τ_1, τ_2, \dots intervallar faqat birgina $A(\tau)$ qonuni asosida taqsimlangan bo'lsa, bunday tasodifiy oqim rekurrent oqim deyiladi. Infokommunikatsiya tarmoqlardagi axborot oqimlarning ketma-ket buyurtmalar orasidagi intensivlik λ va taqsimlash qonuni $A(\lambda)$ vaqt o'tishi bilan o'zgarmasa, bunday buyurtmalar oqimi statsionar oqim deb ataladi. Aks holda buyurtmalar oqimi nostatsionar bo'ladi. Infokommunikatsiya tarmoqlardagi axborot oqimlarning har bir vaqt momenti t_κ da faqat bitta buyurtma paydo bo'lsa, bunday buyurtmalar oqimi ordinar buyurtmalar oqimi deb ataladi. Agar vaqtning har qanday momentida birdan ortiq buyurtmalar paydo bo'lsa, noordinar yoki guruxli buyurtmalar oqimi deyiladi. Infokommunikatsiya tarmoqlardagi axborot oqimlarning buyurtmalarning tushishi bir-biriga bog'liq bo'lmasa, ya'ni navbatdagi buyurtmaning tushish momenti, shu momentgacha qachon va qancha buyurtmalar tushiganiga bog'liq bo'lmagan buyurtmalar oqimi mustaqil oqim deyiladi. Mustaqil statsionar ordinar oqim oddiy oqim deyiladi. Oddiy oqimda buyurtmalar orasidagi vaqt intervallari τ taqsimlash funksiyali eksponensial qonuni bilan taqsimlangan.

$$A(\tau) = 1 - e^{-\lambda\tau} \quad (1)$$

bu yerda $\lambda > 0$ – taqsimot parametri, ya'ni infokommunikatsiya tarmoqlardagi axborot oqimlarning buyurtmalar oqimi intensivligi.

Infokommunikatsiya tarmoqlardagi axborot oqimlarini boshqarishda berilgan vaqt oralig'i τ da tushadigan buyurtmalar soni k Puasson qonuni bo'yicha taqsimlansa, oddiy oqim ko'pincha Puasson oqimi deyiladi:

$$P(k, t) = \frac{(\lambda t)^k}{k!} e^{-\lambda t} \quad (2)$$

bu yerda $P(k, t)$ – bir qancha fiksirlangan t vaqt intervalida k ta buyurtmalarning tushish ehtimoli; λ buyurtmalar oqimining intensivligi. Bu yerda k – butun sonlarni qabul qiladigan diskret tasodifiy kattalik: $k=0, 1, 2, \dots, t > 0$ va $\lambda > 0$ – Puasson qonuni parametrlari.

Shuni aytib o'tish kerakki, Puasson oqimi oddiy oqimdan farq qilib, quyidagicha bo'lishi mumkin:

- agar intensivlik λ vaqt o'tish bilan o'zgarmasa, statsionar oqim;
- agar oqim intensivligi vaqtga bog'liq bo'lsa nostatsional oqim: $\lambda = \lambda(t)$

Shubilan birga oddiy oqim tavsiflanishi bo'yicha statsionardir.

Ommaviy xizmat ko'rsatish modellarining analitik tadqiqoti ko'pincha o'ziga hos xususiyatlarini hisobga olmagan holda oddiy oqim haqidagi shartlarda o'tkaziladi.



1. Oqimlar yig'ish (birlashtirish). Intensivligi $\lambda_1, \dots, \lambda_n$ bo'lgan statsionar ordinar bo'lgan oqimlarning yig'indisi H , qo'shilayotgan oqimlar umumiy oqimga kam ta'sir ko'rsatish sharti bilan, intensivligi

$$\Lambda = \sum_{k=1}^H \lambda_k \quad (3)$$

bo'lgan oddiy oqim hosil qiladi. Amaliyotda yig'indi oqim $H \geq 5$ bo'lganda oddiy oqimga yaqin bo'ladi. Darhaqiqat, multiservis infokommunikatsiya tarmoqlardagi axborot oqimlarning bog'liq bo'lmagan oddiy oqimlarni yig'ilyotganda umumiy oqim N ning har qanday kattaligida oddiy oqim bo'ladi.

2. Infokommunikatsiya tarmoqlardagi oqimlarning siyraklanish extimolligi. Oddiy buyurtmalar oqimining ixtiyoriy buyurtmasi r ehtimollik bilan tasodifiy holda boshqa buyurtmalar rad etilgan yoki etilmaganligiga bog'liq bo'lmagan holda rad etilganda ehtimolli (determinirlanmagan) siyraklanish intensivligi $\lambda' = p\lambda$ bo'lgan oddiy oqimni paydo bo'lishiga olib keladi, bu yerda λ – boshlang'ich oqimning intensivligi. Rad etilgan oqim ham intensivligi $\lambda'' = (1-r)\lambda$ bo'lgan oddiy oqimni hosil qiladi.

3. Oddiylik. Oddiy oqim buyurtmalari haqida taxminlar ko'pgina matematik modellar uchun xarakteristikalarining parametrlarga bog'liqligini nisbatan oson va aniq olishga imkon beradi. Oddiy buyurtmalar oqimi uchun ko'p sonli analitik natijalar olingan. Oddiy bo'lmagan buyurtmalar oqimi modelining tahlili odatda matematik amallarni qiyinlashtiradi va har doim ham aniq ko'rinishdagi analitik yechimni olishga imkon bermaydi. O'zining "oddiy" oqim deb nomlanishini ana shu hususiyati tufayli olgan. Multiservis infokommunikatsiya tarmoqlardagi axborot oqimlarning buyurtmalarga xizmat ko'rsatish vaqti – buyurtmaning qurilmada bo'lish vaqti – umumiy holda, kattalik tasodifiy va $B(\tau)$ funksiyasi yoki taqsimot zichligi $b(\tau) = B(\tau)$ bilan yoziladi. Turli klass buyurtmalariga xizmat ko'rsatish vaqtining yuklamasi bir jinsli bo'lmagan holda, taqsimlash qonunlari yoki faqat o'rtacha kattalik bilan farq qilishi mumkin. Odatda har bir klass buyurtmalariga xizmat ko'rsatish vaqtining bog'liq emasligi ko'rsatiladi.

Odatda buyurtmalarga xizmat ko'rsatish vaqti eksponensial qonunbo'yicha taqsimlangan deb tahmin qilinishi analitik amallarni soddalashtiradi. Tizimida bo'ladigan jarayon vaqt intervallarining eksponensial taqsimlanishimarkov jarayonidir .

Xizmat ko'rsatish o'rtacha vaqti b ga teskari kattalik vaqt birligida xizmat ko'rsatilishi mumkin bo'lgan buyurtmalar o'rtacha sonini xarakterlaydi va xizmat ko'rsatish intensivligi deb ataladi: $\mu = 1/b$

Ko'p hollarda analitik bog'liqliklar buyurtmalarga xizmat ko'rsatish vaqtining ixtiyoriy taqsimot qonuni uchun olingan bo'lishi mumkin. Bunda xizmat ko'rsatish xarakteristikasining o'rtacha kattaligini aniqlash uchun qisman, quyida ko'rsatilishicha, matematik kutish b dan tashqari taqsimotning ikkinchi momenti (dispersiya) yoki xizmat ko'rsatishning variatsiya koeffitsiyenti ν_b ning berilishi kifoya qiladi.

T_0 vaqt bir nechta buyurtmalarni tizimga tushish momentidan, shuni hisobga olish kerakki, tushish momentida tizimda buyurtma bo'lmashligi, ya'ni, tizim bo'sh bo'lishi ham mumkin, qurilmadagi buyurtmalarga xizmat ko'rsatish tugallanguncha qolgan vaqt, xizmat ko'rsatilguncha bo'lgan vaqt deyiladi. Bu vaqtning matematik kutilmasi:

$$M[T_0] = \lambda b^2 (1 + \nu_b^2) / 2 \quad (4)$$

bu yerda λ – tizimga tushgan oddiy buyurtmalar oqimining intensivligi. Bunday mezon

ko'rsatkichi asosida optimal masala qo'yilishining dolzarbligi bir tomondan, infokommunikatsiya tarmog'i ishochliligini oshirish uchun kerakli harakatlar qilinmasa, foydalanuvchilarning so'rovlari o'z vaqtida va sifatsiz bajarilishi oqibatida kompaniyaning yo'qotishlari ko'payib ketish ehtimolligi oshib ketadi, ikkinchi tomondan - ishonchlilik ko'rsatkichlarini haddan tashqari oshirilishi ajratilgan harajatlarni keskin ko'payishiga olib keladi [7].

Infokommunikatsiya tarmoqlardagi byurtmalarni tushish va ularga xizmat kursatish jarayonlarini modellashtirish eng muhim vazifalardan biri - parametrik sintezida erishiladigan xizmat ko'rsatish talab etiladigan sifatini ta'minlash. Parametrik sintez usullari chiziqli va nochiziqli modellarni ishlatish, uzatilayotgan oqimlar parametrlari va xizmat ko'rsatish sifat parametrlari orasidagi funksional va ehtimolli bog'liqliklarni inobatga olish imkoniyatini beradi.

Xulosa

Ushbu tadqiqotlarni asosiy ilmiy va amaliy natijasi bu infokommunikatsiya tarmoqlarida axborot oqimlarini qayta ishlash jarayonini taqsimlash vazifasini extimoyiligini optimallashtirish kommunikatsion tugunlari orqali o'tishda axborotlarning ushlanib qolinishning o'rtacha vaqtning hisob infokommunikatsiya tarmoqlaridagi kommutatsion tugunlar orqali xabarni o'rtacha to'xtab turish vaqtini hisoblashning noravshan modeli keltirilgan. Bunda kommunikatsion tugunning har bir kanali umumiy xizmat tarmog'i kabi modellashtiriladi tarmoqlarida axborot oqimlarini qayta ishlashni taqsimlash vazifasini extimoyiligini aniqlash ishlab chiqilgan.

“Infokommunikatsiya tarmoqlarda buyurtmalarni tushish va ularga xizmat kursatish jarayonlarini modellashtirish” mavzusidagi maqolada o'tkazilgan tadqiqotlar natijalari quyidagi xulosalarni qilishga imkon beradi:

1. Tizimli yondashuv asosida infokommunikatsiya tarmoqlarida axborot oqimlari trafiklarini boshqarish tizimi samaradorligining asosiy sifat ko'rsatkichlari, ularga ta'sir etuvchi asosiy faktorlar va sodir bo'ladigan turli jarayonlar tahlil qilindi. Bu esa infokommunikatsiya tarmog'i samaradorlik ko'rsatkichlarining o'zaro bog'liqligini tasvirlovchi axborot oqimlari trafiginini boshqarish modelini nazariy to'plam shaklida qurish imkonini berdi.

2. Taklif etilgan neyro-noravshan texnologiyani axborot oqimlari trafiginini boshqarish tizimi samaradorligini baholashda qo'llash, tarmoqda sodir bo'ladigan jarayonlarni yuqoriroq aniqlikda ifodalash imkonini beradi.



Adabiyotlar

1. Бычков Е.Д. Математические модели управления состояниями цифровой телекоммуникационной сети с использованием теории нечётких множеств: монография / – Омск: Изд-во ОмГТУ, 2010. – 236 б.;
2. A.F.Izbosarov, Z.Z.Nigmatov, A.A.Yahyoev Mudofaa vazirligi telekommunikatsiya tarmoqlarida axborot oqimlari trafigini boshqarishning neyro-noravshan modellari va algoritmlari (Maxfiy). // M.: Toshkent, 2022, AKT va ANI, - B 100
3. A.F. Izbosarov, Z.Z. Nigmatov Boshqaruv tizimidagi telekommunikatsiya tarmog'idagi axborot oqimlari trafigini boshqarishning o'tkazish qobiliyatini modellashtirish algoritmlari // Axborot – kommunikatsiya texnologiyalari va aloqa harbiy instituti IV Xalqaro ilmiy-amaliy konferensiyasi «Professional armiya boshqaruvini rivojlanishida innovatsiyalar va raqamlashtirishning o'rne» Ma'ruzalar to'plami 12 aprel 2022-yil. I-sho'ba. 7-9 bet
4. Избосаров А.Ф., Нигматов З.З., Яхёев А. А. Формализация критерия эффективности управления сообщениями информационно-телекоммуникационной сети // Axborot – kommunikatsiya texnologiyalari va aloqa harbiy instituti IV Xalqaro ilmiy-amaliy konferensiyasi «Professional armiya boshqaruvini rivojlanishida innovatsiyalar va raqamlashtirishning o'rne» Ma'ruzalar to'plami 12 aprel 2022-yil. I-sho'ba. 9-14 bet



Muallif

Sherzod Abduraimov

Raqamli iqtisodiyot va moliyaviy texnologiyalar kafedrası, "University of Management and Future Technologies" universiteti,

Toshkent, 100208, O'zbekiston;
ameoromantik@gmail.com

BLOKCHEYN TEXNOLOGI- YASINING QO'LLANILISHI VA NAZARIY JIHATLARI

Annotatsiya: Ushbu maqolada, blokcheyn texnologiyasi haqida asosiy tushunchalar, blokcheyn texnologiyasining nazariy asoslari, blokcheyn texnologiyasining qo'llanilish sohalari, blok zanjirlarini shakllantirish texnologiyasi, blok umumiy ko'rinishi, tranzaksiyalar, blok korpusi shakllantirilishi, blokcheynga bo'ladigan kriptohujumlar tasnifi haqida fikr yuritilgan.

Kalit so'zlar: Blokcheyn texnologiyasi, blokcheyn imkoniyatlari, qo'llanilish sohalari, blok tuzilishi, blok tizimi, heshlash.



Copyright: © 2024 by the authors.

Ushbu maqola Creative Commons Attribution (CC BY) litsenziyasi shartlari asosida tarqatiladigan ochiq foydalanish maqolasi hisoblanadi (<https://creativecommons.org/licenses/by/4.0/>).

APPLICATION AND THEORETICAL ASPECTS OF BLOCKCHAIN TECHNOLOGY

Abstract: In this article, the basic concepts of blockchain technology, theoretical foundations of blockchain technology, areas of application of blockchain technology, block chain formation technology, block overview, transactions, block body formation, and classification of cryptoattacks on blockchain are discussed.

Keywords: Blockchain technology, blockchain capabilities, fields of application, block structure, block system, hashing.



Author

Sherzod Abduraimov

Department of Digital Economy and Financial Technologies, University of Management and Future Technologies,

Tashkent, 100208, Uzbekistan;
ameoromantik@gmail.com



Copyright: © 2024 by the authors.

This article is an open access article distributed under the terms and conditions of the Creative Commons Attribution (CC BY) license (<https://creativecommons.org/licenses/by/4.0/>).

Kirish

Hozirgi kunda, butun dunyoda blokcheyn texnologiyasi jamiyatning ijtimoiy iqtisodiy va hakazo sohalarida keng qo'llanilmoqda. Blokcheyn texnologiyasi axborot kommunikatsiya sohasida katta burilish yasadi. Bu burilishni internet yaratilishi bilan qiyoslash mumkin. Jamiyat va undagi insonlar hayoti pul, ma'lumotlar va hujjatlar bilan bog'liqdir. Shunga bog'liq holda biz pul, hujjat va axborotlarni beruvchi, ularni tekshirib haqiqiyiligini kafolatlovchi, har hil turdagi vositachilar bilan munosabatda bo'lamiz.

Shuning uchun biz tarmoqdagi vositachiga ishonch bildirishga majbur bo'lamiz. Misol uchun, hozirgi kunda bank haridorlarining mablag'lari haqidagi ma'lumotlari konfidentsialligini ta'minlash, notarial idora xizmatchilarining noqonuniy shartnomalar tuzish kabi hatti – harakatlarga urinishlar, davlat tashkilotlari va tijorat tashkilotlari xizmatchilarining o'z manfaatlari yo'lida davlatga ziyon keltiruvchi hatti-harakatlarni amalga oshirishga urinishlari korrupsiya, davlat mulkini talon taroj qilish kabi harakatlar amalga oshirilayotgani hech birimizga sir emas.

Albatta bu kabi muammolarning chuqur ildiz otishi yurtimizning ijtimoiy, iqtisodiy, siyosiy sohalarida rivojlanish bosqichlarida ortda qolishiga mamlakatimiz aholisining ko'pgina qatlamlarida qashshoqlik, ocharchilik, ijtimoiy himoyasizlik kabi og'ir oqibatlarga olib keladi. Albatta bu muammolarning yechishning mamlakatimizda aniq strategiyalari belgilangan. Asosan, bu borada 2017-2021 yillarda O'zbekiston Respublikasini rivojlantirishning beshta ustivor yo'nalishi bo'yicha harakatlar strategiyasida keng qamrovli vazifalar belgilab berilgan. Albatta, harakatlar strategiyasining ustivor vazifalari bajarilayotgan holda mamlakatimizda ko'pgina ijtimoiy iqtisodiy o'zgarishlar, yangilanishlar yuz bermoqda. Lekin, hozirgi kunda axborot texnologiyalarining mamlakatimizning ko'pgina sohalariga qo'llanilishi, ko'pgina davlat va molyaviy xizmatlarning masofaviy tizimlar yordamida bajarilishi, tizimlar orqali moliyaviy amallarni bajarishda vositachilardan foydalanilishi natijasida tizimlar xavfsizligiga tahdidlar, tizimdagi ma'lumotlarning o'zgartirilishi ya'ni konfidentsialligi buzilishi kabi ko'pgina muammolar kelib chiqmoqda.

Hozirgi kunda bu muammolarning yechimi sifatida ko'pgina va xavfsizlikni ta'minlash maqsadida ko'pgina kriptografik algoritmlar va dasturiy vositalar taklif qilinmoqda. Ko'pgina kriptografik algoritmlarda hisoblash masalasi murakkabligi va kriptanalitiklar tomonidan tahlil qilinishi natijasida algoritmlarga nisbatan shubhalar kelib chiqmoqda. Albatta bu muammolarni yechish yangi zamonaviy konfidentsialligi va kriptomustahkamligi yuqori bo'lgan kriptosalgoritim yoki himoya tizimi zarurligi ko'pchilik mutahassislar tomonidan aytilmoqda. Bu turdagi masalalarni yechishda blokcheyn texnologiyasini qo'llash bo'yicha ko'pgina mulohazalar keltirilmoqda. Endi, biz quyidagicha blokcheyn texnologiyasining ijtimoiy, iqtisodiy, siyosiy sohalariga qo'llashning asosiy bosqichlarini ko'rib chiqamiz.

Asosiy qism

Blockchain (inglizcha blokcheyndan) - bu texnologiya, bu ma'lumotlarni kriptografik shifrlar yordamida himoyalash bilan ketma-ket bloklar zanjiriga yig'ishni o'z ichiga oladi. Shu bilan birga, ma'lumotlar zanjirlari alohida serverda saqlanmaydi, lekin tarmoqqa ulangan barcha qurilmalarda bir vaqtning o'zida mavjud.

Blockchain - bu uchinchi shaxslarning ishlashini talab qilmaydigan mustaqil tizim. Bundan tashqari, ko'rib chiqilayotgan tizim juda ochiq. Blokcheynni yaratish jarayonida ishlab chiquvchilarning asosiy maqsadi vositachilardan uzoqlashish edi.

Misol uchun, Blokcheyn texnologiyasi orqali molyaviy ma'lumotlarni ishonchli saqlash mumkin. Kripto valyuta tizimlarida blokcheyn texnologiyasi foydalanuvchilarning virtual pul mablag'larini ishonchli saqlash va sarflash firibgarliklardan asrash imkoniyatini yaratadi. Shuning bilan bir qatorda

blokcheyn texnologiyasini qo'llagan holda abonentlar yoki tashkilotlarning mulkiy huquqlarini, elektron shartnomalar, sog'liqni saqlash tizimidagi maxfiy ma'lumotlar (bemorlarning kasallik varaqasi va shunga o'xshash maxfiy ma'lumotlar), farmaseftika sohasidagi ma'lumotlar (dori darmon maxsulotlarining haqiqiyiligini ta'minlash maqsadida) va nikoh to'g'risidagi ma'lumotlarning konfidentsialligini ta'minlashda keng qo'llaniladi. Umumiy aytganda, barcha matnli va boshqa turdagi ma'lumotlarni blokcheyn zanjirlari bloklarida saqlash ma'lumotlar konfidentsialligini ta'minlashda katta imkoniyat yaratadi. Blokcheyn texnologiyasining boshqa kriptotalgoritmlardan farqi shundan iboratki, blokcheyn bloklariga kiritilgan ochiq yoki maxfiy axborotlarni o'zgartirish, o'g'irlash va shunga o'xshash kripto hujumlarni amalga oshirish kriptotalgoritmlarga yaxshi natija bermaydi.

Mutaxassislarning ta'kidlashicha blokcheyn texnologiyasining keng qo'llanilishi axborot dunyosida sezilarli o'zgarishlarga olib keladi. Bu juda sodda tarzda tushuntiriladi: markazlashtirilmagan ma'lumotlarni saqlash ularni ruxsatsiz o'zgarishlardan himoya qilishga imkon beradi, masalan buzish, buzish yoki har qanday nazorat.

Yana bir muhim narsa ortiqcha texnologiya shu vositachilar (moliya institutlari, to'lov tizimlari) endi kerak emas har qanday ma'lumotlarni uzatish operatsiyalari uchun. Barcha ma'lumotlar protokol yordamida uzatiladi ya'ni to'g'ridan-to'g'ri bir foydalanuvchidan boshqasiga. Tizimning barcha ishtirokchilari operatsiyalar tarixi to'g'risida, shuningdek boshqa ishtirokchilar haqida ma'lumot olish imkoniyatiga ega. Bundan tashqari, barcha tizim ma'lumotlari tarmoqdagi barcha qurilmalarda bir vaqtning o'zida saqlanadi.

Blokcheyn hamyonidagi mablag'larga faqat egasi kirish huquqiga ega. Pul odatda bank bo'lgan vositachilarga topshirilmaydi. Shu tufayli tranzaksiyalar hech kimning nazorati ostida emas.

Yuqorida keltirilgan muammolar yechimi haqida tushunchaga ega bo'lish uchun dastlab blokcheyn zanjirli texnologiyasi haqida tushunchaga ega bo'lish zarur. Blokcheyn texnologiyasi – bu har bir blok oldingi blokiga bog'liq bo'lgan ma'lumotlar bloklarini zanjiri hisoblanadi. Blokcheyn texnologiyasining ishlash printsiplari 1-rasmda keltirilgan.

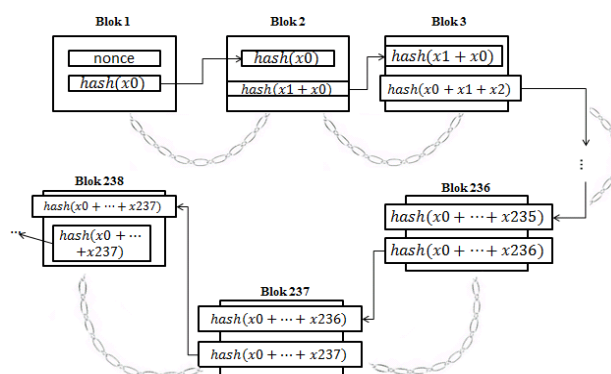

1-rasm. Blokcheyn texnologiyasining ishlash printsiplari umumiy sxemasi

Bunda har bir blok matnli ma'lumotlar yig'indisini tashkil qiladi. Shundan, yangi bloklardagi ma'lumotlar hesh qiymatlari zanjirdagi keyingi blok qiymatiga qo'shiladi. Blokcheyn texnologiyasi quyidagicha printsiplarni o'z ichiga oladi.

- Taqsimlash;
- Ochiqlik;
- Xavfsizlik.

Bu priintsiplar asosida blokcheynning barcha foydalanuvchilari kompyuterlar tarmog'ini shakllantiradi va ularning har birida ma'lumotlar bloklarining nusxalari mavjud bo'ladi. Odatda bu barcha bloklarning to'liq nusxalari bo'lib, biz o'zimizga lozim bo'lgan bloklarni saqlaymiz. Shuning hisobiga blokcheyn bloklaridagi ma'lumotlarga zarar yetkazish, buzish, qayta ishlash, o'chirish mumkin emas, sababi barcha kompyuterlardagi ma'lumotlarni o'chirish yoki o'zgartirish lozim. Blokcheyn kamida bitta foydalanuvchi mavjud tizimdan ixtiyoriy sondagi foydalanuvchi tizimlarigacha qo'llaniladi. Bunda har bir yangi foydalanuvchi bu tizimni kengaytiradi va bardoshlilikni oshiradi.

Tizimdagi barcha foydalanuvchilar teng huquqli bo'lib, tizim tashkilotchilari, moderatorlar, kuzatuvchilar, adminlar tushunchalari bo'lmaydi. Tizimdagi har bir foydalanuvchi o'z bloklari va ma'lumotlariga ta'sir ko'rsata oladi. Blokcheyn bloklaridagi barcha ma'lumotlar ochiq va shifrlangan turda saqlanishi mumkin. Agarda blokdagi ma'lumotlar ochiq turda saqlanadigan bo'lsa, u holda ma'lumot mazmunini osongina o'qish va shu blokning barcha yozuvlarini ko'rish mumkin.

Ma'lumotlarning oochiq holda saqlanishi asosan bu ma'lumotning mazmuni o'zgartirilmasligining oldini olish maqsadida amalga oshiriladi. Bunda har bir foydalanuvchi o'z bloklaridagi ma'lumotlarni ko'ra olishadi va ularni o'zgartirish huquqiga ham ega bo'ladi.

Bunda asosan kriptografik kalitlar qo'llaniladi. Blokcheyn texnologiyasi ishonchli, xavfsizligi ta'minlangan, ma'lumotlarning konfedentsialligi va haqiqiyiligini oson va ishonchli tekshirish imkoniyatini beruvchi kriptografik kalitlar bilan amalga oshiriladi. Bunda kalit sifatida 256, 512 bit uzunlikdagi tub sonlar qo'llaniladi. Misol uchun,

$K=117316195423570985008687907853269984665640564039457584007913129639935$

yuqorida aytib o'tganimizdek, mazkur kalit hesh funksiya (SHA, SHA1, SHA2, SHA256, SHA512, MD3, MD4, MD5 h.k.) algortimlari orqali hisoblanadi. Kiruvchi boshlang'ich ma'lumotlarni heshlash natijasida yangi kalitlar hisoblanadi. Heshlash jarayoni shunday hususiyatga egaki, kiruvchi ma'lumotlarda kichik o'zgarishlar yuz bersa natija to'lig'i bilan o'zgaradi. Bu jarayon quyidagicha 1-jadvalda keltirilgan.



1-jadval. Hesh funksiya asosida bloklarda kalitlarni hisoblash jarayoni

Blok Raqami	Nonce	Boshlang'ich ma'lumotlar (Kiruvchi ma'lumotlar)	Kalit (Hesh qiymat)
1	35036	Raximberdiyev Quvonchbek kredit miqdori yuz million so`m.	00009c9de3e7742b9cd648ea8cafbf90cc9a5ffde5b1aae5c5bb61b20883b112
2	94043	Raximberdiyev Quvonchbek kredit miqdori yuz million so`m!	0000cce0f7c5a00a13d17e11324492f09b3d7db7318ea428c04b639121bf1fa6
3	70341	Raximberdiyev Quvonchbek kredit miqdori yuz million so`m?	0000d1a5b2b94d622a2222a53dca5c1dfbea96acab4726de237d8fb7bc99f40c
4	34704	Raximberdiyev Quvonchbek kredit miqdori yuz million so`m,	000056a9b802dd9a07301593566c1068b941422ee49d2376252ed762476f99f6
5	50005	Raximberdiyev Quvonchbek kredit miqdori yuz million so`m\$	0000ac19c9489f8acd8317bb2e6dc96ea72344ed7f74f44320566ac121cf42c5
6	63821	Raximberdiyev Quvonchbek kredit miqdori yuz million so`m&	00008fd9da0892deb6b34e82b7cfe30d76a90a15fa54c9e8d6022e53ebfde0e5

Blokcheyn tizimi. Blokcheyn zanjirlaridagi barcha ma'lumotlar foydalanuvchilar kompyuterlarida saqlanadi. Tizim foydalanuvchilari teng huquqli bo'lib, ular har hil turdagi amallarni bajarishlari mumkin. Jumladan, tahdid va fribgarlik qilishga urinishlar bo'lishi mumkin. Lekin blokcheyn tizimi markazlashtirilmaganligi sababli tizimda markaziy administrator mavjud emas. Shundan yuqorida aytganimizdek barcha foydalanuvchilar o'z bloklarini boshqaradilar va bloklardagi yozuvlarni yo'q qilish imkoniyatiga ham ega bo'ladilar. Blokcheyn texnologiyasini sohalarga qo'llagan holda boshqaruv tizimini yaratish tizimlardagi vositachilarga, banklarni vositachi dasturiy ta'minotlariga, davlat haqiqiylikni tasdiqlovchi bo'limlariga, auditorlar, kuzatuvchilar, sug'urta kompaniyalarining qisman turlari yordamidan voz kechish imkoniyatini yaratadi (2-rasm).

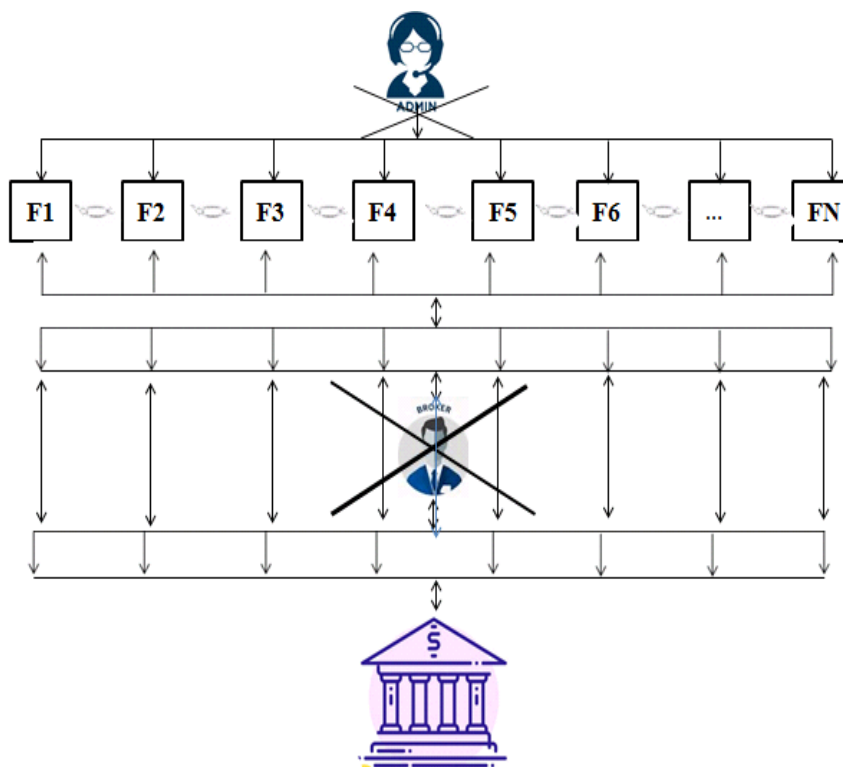

2-rasm. Blokcheyn texnologiyasi asosida bloklarni boshqaruv tizimi sxemasi

Yuqoridagi sxemadan ma'lumki, blokcheyn asosidagi tizimlar markazlashmagan bo'lib, asosan geografik joylashuvlarga, ya'ni mamlakatlar chegaralariga bog'liq emas. Bunda, oddiy shaxarlarimizdagi foydalanuvchi to'g'ridan to'g'ri Moskva, London, Nyu – York, Parij hakazo shaxarlardagi foydalanuvchilar bilan havfsiz aloqa o'rnatishlari mumkin.

Blok tuzilishi. Blokcheyn bloklari sarlavha va blok tanasidan tuziladi. Bloklardagi yozuvlar tizimi blok korpusi deb ataladi.

Bunda asosan bloklarning BLOK N sarlavhasiga katta e'tibor berish lozim. Sababi, yozuvlardagi asosiy maxfiy xabarlar shu blokning sarlavha qismida saqlanadi. Blokcheyn zanjiridagi barcha bloklarni kalitlar yordamida biriktiradi, bunda, har bir blokning kaliti o'zidan keyingi har blokning sarlavhasiga qo'shib boriladi. Bu juda muhim amallardan bo'lib, bir vaqtning o'zida blokning xavfsizligini va buzilmasligini kafolatlaydigan texnik yechim bo'lib hisoblanadi.

Yuqorida, aytganimizdek, har bir blokning kaliti, umumiy bloklar bilan oldingi blokning kaliti ma'lumotlarini foydalangan holda hisoblanadi. Bu jarayonlar bo'yicha quyidagicha mulohazalarni keltiramiz.

Birinchiidan, blok disklarida faqatgina shu blokgina emas, oldingi bloklarning yozuvlari kodlanadi. Bloklarda ixtiyoriy blokdagi ma'noga ega bo'lmagan bitta simvolning o'zgarishi kalitlarning to'liq o'zgarishiga olib keladi(1-jadvalga qarang), albatta bu o'z navbatida barcha keyingi bloklarning kalitlarining o'zgarishini talab qiladi. Shunday qilib, barcha blokcheyn zanjiri bloklari kalitlarini ko'rgan holda, ixtiyoriy ma'lumotlatning haqiqiyiligini tekshirish mumkin. Tekshirish jarayonida, tartib raqami to'g'ri kelmaydigan yoki zanjirning ixtiyoriy bo'lagiga qo'shilgan yangi bloklarda kalit asosan bloklarga kiritilgan yozuvlarning o'zi bo'ladi. Umumiy qilib aytganda, ma'lumotlarning haqiqiyiligiga va konfidentsialligiga oson ishinch hosil qilish mumkin.



Ikkinchidan, blokning kaliti tizim xavfsizligining darajasini belgilovchi muhim xavfsizlik qoidalarini qanoatlantirishi kerak, tizimning havfsizlik darajasi blokcheyn zanjirlaridagi bloklar soni o'sishi natijasida o'zgaradi. Bunda, bloklarning kalitlari nollardan tuzilgan holda boshlanishi kerak. Kalitlarning bu turdagi generatsiyasi yangi haqiqiy va sun'iy bloklarni yaratishga imkoniyat yaratadi. Lekin, shuni e'tirbarga olish kerakki har bir ma'lumotlar yig'indisi uchun ixtiyoriy vaqt momentida bitta o'zgarma kalit qo'llaniladi. Endi blokcheyn zanjirlari bloklariga qo'llaniladigan kalitlarni yasash jarayonini ko'rib chiqamiz.

Kalitlarni yaratish (mining) jarayoni. Kalitlarni yasash jarayoni mayning deb ataladi. Bu jarayonni mayner amalga oshiradi. Mayner bu blokcheyn texnologiyasi tizimining foydalanuvchisi bo'lib, bloklardagi ma'lumotlarni tekshirish, tarqatish va blokcheyn zanjirlaridagi bloklarni yasash jarayonini ham amalga oshiradi. Mayner boshqa tizim bloklari qismlaridan yangi yozuvlarni qabul qilgandan so'ng, ularni biriktirib qurilayotgan yangi blokning sarlavhasini yasaydi va blok kaliti hisoblaydi. Dastlabki hisoblashlardan keyin quyidagicha kalit hisoblanadi.

$$\langle k_2 = 3117316195423570985005687907853269984665640589182146373136582 \rangle$$

Lekin, yuqorida aytganimizdek kalit qoidalariga mos turda boshlang'ich sonlari nollardan boshlanishi lozim. Bunda, k_2 kalit ustida berilgan qoidalar bajarilmadi. Bu muammoni hal qilishda kalitlar generatsiyasini qayta amalga oshirish kerak ya'ni kiruvchi ma'lumotni kalit nollardan boshlanguncha o'zgartirish lozim. Ammo bu juda murakkab bo'lib, uni qayta hisoblab natijaga olib kelishinig imkoniyati yo'q. Kelib chiqqan bu muammoni yechishda, blok sarlavhasida «NONCE» deb nomlanuvchi maydon ishlab chiqildi. Bu maydonda dastlabki hisoblashlar qiymati 0 bo'ladi. Shundan so'ng mayner blokga 1 qiymatini beradi va kalitni qayta hisoblaydi. Natijada quyidagicha k_3 kaliti hosil bo'ladi.

$$k_3 = 687907883269311731610988008146984665640589137313658295423575$$

Bunda, k_3 kalitining dastlabki raqamlarini nollar tashkil qilmadi, demak jarayon yana davom etadi. Mayner bu jarayonda milliyard, trillion amal bajaradi.

Xulosa

Xulosa qilib aytganda, blokcheyn texnologiyasining qo'llanilishi yuqori daraja himoyalanihga olib keladi. Albatta bu yuqorida keltirilgan mulohazalarning qo'llanilishi natijasida amalga oshiriladi. Yuqoridagi mulohazalardan kelib chiqqan holda blokcheyn texnologiyasining qanchalik murakkab strukturaga ega ekanligining guvohi bo'ldik. Blokcheyn texnologiyasining kriptobardoshlilikini aniqlashda esa mumkin bo'lgan kriptohujum va firibgarliklarning nazariy tarafdin imkonsiz ekanligini ilmiy tadqiqot natijasida ko'rib chiqdik.

Bu kabi ishochning mustahkamlanishi barcha harakat qilgan holda yurtimizning ertangi kuni uchun rivojlanishi uchun xizmat qiladi.

Adabiyotlar

1. Melanie Swan. All rights reserved / Перевод. Блокчейн. Схема новой экономики. - М. Свон- «ОлимпБизнес», 2015
2. O'zbekiston Respublikasi Prezidentining 2018-yil 3-iyuldagi "O'zbekiston Respublikasida raqamli iqtisodiyotni rivojlantirish chora-tadbirlari to'g'risidagi" PQ-3832-sonli qarori.
3. O'zbekiston Respublikasi Prezidentining 2020-yil 5-oktyabrdagi "“Raqamli O'zbekiston-2030” strategiyasini tasdiqlash va uni samarali amalga oshirish chora-tadbirlari to'g'risida”gi PQ-6079-sonli qarori.
4. Gulyamov S.S. va boshqalar. "Raqamli iqtisodiyot" Darslik. -T.:TDIU, 2020 y.-409 b.
5. Digital Economy report 2019, Value creation and capture: implications for developing countries. https://unctad.org/system/files/official-document/der_2019_en.pdf.
6. S.S.Gulyamov, R.H.Ayupov, O.M.Abdullaev, G.R.Baltabaeva. "Raqamli iqtisodiyotda blokcheyn texnologiyalar". T.: TMI, "Iqtisod-Moliya" nashriyoti, 2019, 447 bet.
7. URL: <https://russian.rt.com/tag/blockchein>

JAHON IQTISODIYOTINING RAQAMLI TRANSFOR- MATSIYASI: TENDENSIYALAR VA ISTIQBOLLARI

Annotatsiya: Mazkur maqolada jahon iqtisodiyotining raqamli transformatsiyasi tendensiyalar va istiqbollari, onlayn tizim, raqamli texnologiyalar, barcha soha va insonlarning kundalik hayotiga shiddat bilan kirib ijobiy o'zgarishlarga sabab bo'lib borayotganligini va iqtisodiyotni raqamlashtirish tarmoqlarda tejamkorlik va samaradorlikni ta'minlashi, iqtisodiyot tizimini raqamlashtirish, onlayn shaklida hisobotlar shakllantirish bugungi kun talabi bo'lib borayotgani haqida.

Kalit so'zlar: jahon iqtisodiyotining raqamli transformatsiyasi, tendensiyalar va istiqbollari, onlayn to'lov, raqamli texnologiyalar, tizimini raqamlashtirish, axborot kommunikatsiya, sun'iy intellekt, axborot texnologiyalari.



Muallif

**Djangirova Umida
Abdugalimovna**

Raqamli iqtisodiyot va moliyaviy texnologiyalar kafedrasini, "University of Management and Future Technologies" universiteti,

Toshkent, 100208, O'zbekiston



Copyright: © 2024 by the authors.

Ushbu maqola Creative Commons Attribution (CC BY) litsenziyasi shartlari asosida tarqatiladigan ochiq foydalanish maqolasi hisoblanadi (<https://creativecommons.org/licenses/by/4.0/>).



Authors

**Djangirova Umida
Abdugaliyeva**

Department of Digital Economy and
Financial Technologies, University of
Management and Future

Technologies, Tashkent, 100208,
Uzbekistan;

DIGITAL TRANS- FORMATION OF THE WORLD ECONOMY: TRENDS AND PROSPECTS

Abstract: In this article, the trends and prospects of the digital transformation of the world economy, the online system, digital technologies, are rapidly entering all areas and people's daily lives, causing positive changes, and the digitalization of the economy ensures savings and efficiency in the networks, the digitalization of the economic system, about the fact that creating reports in online form is becoming a requirement today.

Key words: digital transformation of the world economy, trends and prospects, online payment, digital technologies, system digitization, information communication, artificial intelligence, information technologies.



Copyright: © 2024 by the authors.

This article is an open access article distributed under the terms and conditions of the Creative Commons Attribution (CC BY) license (<https://creativecommons.org/licenses/by/4.0/>).



Kirish

Raqamli iqtisodiyot texnologiyalarning jadal rivojlanishi, axborot sohasida inqilob va iqtisodiyotning globallashuv jarayonlarini tezlashtirish bilan ajralib turadi. Iqtisodiyotning raqamli sektorini rivojlantirish borasida davlat tomonidan keng ko'lamli chora-tadbirlar ko'rilmoqda, elektron hujjat aylanishi tizimlari joriy etilmoqda, elektron to'lovlar rivojlantirilmoqda va elektron tijorat sohasidagi normativ-huquqiy baza takomillashtirilmoqda [1]. Misol tariqasida ushbu ko'rsatgichlarga nazar solsak.

Turli tadqiqotlar natijalari bo'yicha raqamli iqtisodiyotning dunyo iqtisodiyotidagi salmog'i 4,5 foizdan 15,5 foizgachani tashkil etadi. Jahon axborot-kommunikatsiya texnologiyalari sektorida yaratilayotgan qo'shilgan qiymatning deyarli 40 foizi va blokcheyn texnologiyalari bilan bog'liq patentlarning 75 foizi Amerika Qo'shma Shtatlari va Xitoy Xalq Respublikasi hissasiga to'g'ri keladi. Mamlakatimiz Prezidenti Sh.M. Mirziyoevning 2020-yil 13-fevral kuni axborot texnologiyalarini rivojlantirishga bag'ishlangan tadbirda keltirgan statistik ma'lumotlariga muvofiq AQShda raqamli iqtisodiyotning yalpi ichki mahsulotdagi ulushi 10,9 foiz, Xitoyda 10 foiz, Hindistonda 5,5 foizni tashkil etadi. O'zbekistonda bu ko'rsatkich 2 foizdan ham oshmaydi. Raqamlashtirishning ahamiyati va ta'sirini qanchalik ortib borayotganligini baholash uchun so'nggi o'n yillikdagi bir nechta yirik texnologik kompaniyalar va raqamli platformalarning jahon bozoridagi kapitallarining ulushini ko'rish kifoya. Axborot asri deya e'tirof etilayotgan bugungi kunimizda axborot kommunikatsiya tizimi izchil rivojlanishda davom etmoqda.

Bugun zamonaviy axborot texnologiyalarisiz hayotimizni tasavvur etib bo'lmaydi. Mamlakat darajasida ushbu soha rivoji muhim omillardan biriga aylangan. Shu bois ham mamlakatimizda telekommunikatsiya tarmoqlarini rivojlantirishga alohida e'tibor qaratib kelinmoqda. Ayniqsa sohani xalqaro andozalarda mexanizatsiyalashtirish va rivojlantirish ustuvor yo'nalishlar sifatida belgilab olingan. Amaliy harakatlar natijasida yurtimizning yaqin va olis mintaqalarida axborot resurslarini yaratish va undan foydalanish samaradorligi oshirilmoqda. Davlatning raqamli iqtisodiyotni rivojlantirish yo'lini tanlaganligi axborot texnologiyalari sohasida va umuman, elektron hujjatlar aylanmasi sohasida yangi yo'nalishlar ochib beradi. "Raqamli texnologiyalar" tomon burilishga butun jahon internet tarmog'i va sifatli aloqaning rivojlanishi sababchi bo'ldi [2].

Asosiy qism

Raqamli iqtisodiyotning eng faol drayveri -bu davlatdir. U raqamli iqtisodiyotning asosiy buyurtmachisi va iste'molchisidir. Masalan, Xitoy bu maqsadlar uchun 9 mlrd dollar atrofida mablag' sarflagan. Bozor kapitalizatsiyasi 210 mlrd dollardan ziyod bo'lgan, alibaba internet resursi ushbu sarmoyalarning to'g'ri yo'naltirilganini isbotladi.

Raqamlashtirishdan maksimal foyda olishni istagan davlat, zaruriy yuqori texnologik mahsulotlarning bozorini yaratishi va uni qo'llab-quvvatlashi lozimdir. Shu bilan birga, parallel tarzda davlat boshqaruvi, muhim sohalar va korxonalar uchun xususiy ilovalarni rivojlantirgan holda, elektron iqtisodiyotning asosiy platformalarini nazorat qiluvchi instrumentlarni o'z izmida saqlab qolish ham muhim hisoblanadi. Xususan, Yaponiya texnologiyalarni xarid qilgan bo'lsa-da, ushbu yo'nalishda o'zining ishlab chiqaruvchi tarmoqlarini yaratilmagani va texnik ishlanmalar darajasini muttasil yuqori holatda tutilmagani tufayli, raqamli iqtisodiyotdagi yetakchi pozitsiyalarni qo'ldan boy berdi. Janubiy Koreya esa elektron hukumat va elektron vositachilikka (elektron tijorat faoliyati va davlat tender xaridlarini o'tkazish uchun) milliy byudjetning 1 foiziga teng miqdorda sarmoya kiritib, har yili 10-15 milliard dollar hosil qilmoqda va harajatlarni 30-40 baravar qoplaydigan daromad olmoqda. Jumladan, davlat va xususiy sektorda call-markazlarni tashkil qilish, mobil ilovalarni yaratish va davlatga tegishli internet-platformalarni reinjining qilish orqali mana shunday natijaga erishildi [3].

Hozirgi vaqtda ilmsizlik johillikning tomir yoyishiga alal oqibat yurt parokanda bo'lishiga olib keladi. Ilmiy adabiyotlarda hozirgi zamon "Yangi raqamli iqtisodiyoti" turli xil atamalar bilan nomlanadi. Masalan, Raqamli iqtisodiyot tushunchasiga bir qator ta'riflar berilgan. Jumladan, iqtisodiyot fanlari doktori, Rossiya Fanlar akademiyasining muxbir a'zosi V.Ivanov "Raqamli iqtisod - haqiqatimizni to'ldiradigan virtual muhit" - deb ta'rif bergan [4].

Birinchi marta 1995-yilda amerikalik dasturchi Nikolas Negroponte "Raqamli iqtisodiyot" terminini amaliyotga kiritgan bo'lsa, hozirda bu istilohni butun dunyodagi siyosatchilar, iqtisodchilar, jurnalistlar, tadbirkorlar – deyarli barcha kasb egalari qo'llamoqda. Raqamlashtirish jahon iqtisodiyotining o'sishiga olib keladi, masalan, nufuzli McKinsey Global Institute konsalting kompaniyasining hisob-kitoblariga ko'ra, eng yangi raqamli texnologiyalardan foydalanish 2025-yilga borib yalpi ichki mahsulot (YaIM) o'sishiga olib keladi. Butun dunyo bo'ylab. 3-6 trillion dollarni tashkil etadi. Kompaniyaning hisob-kitoblariga ko'ra, 12 turdagi yuqori texnologiya (mobil Internet, ilg'or robototexnika, bulutli texnologiya, qayta tiklanadigan energiya, Internet of Things (IoT) ma'lumotlari bu o'sishga hissa qo'shadi. Sim-siz uzatish, harakatchanlik va sun'iy intellekt va boshqalar). Ayni paytda butun dunyo bo'ylab yirik kompaniyalar raqamlashtirish haqiqatidan xabardor va bulutli texnologiyalar va tarmoq infratuzilmasini modernizatsiya qilish bo'yicha ko'rsatmalarga ega. Raqamlashtirish, raqamli iqtisodiyotni shakllantirish iste'molchilar, davlat, umuman, jamiyat uchun katta imkoniyatlar ochib beradi. Raqamli iqtisodiyotni qo'llab-quvvatlash bo'yicha dunyoning yetakchi davlatlari qatorida Singapur, Xitoy, Janubiy Koreya, Yangi Zelandiya va Daniya bor. Bu mamlakatlar raqamlashtirish va yuqori texnologiyalarni shakllantirish sohasida salmoqli tashabbuslar bilan chiqdi. Tomsk davlat universitetining professori, R.Meshcheryakovning fikricha "Raqamli iqtisod" atamasiga ikkita yondashish mavjud deb hisoblaydi. Raqamli texnologiyalar asosida iqtisodiyotning va elektron tovar va xizmatlar eksklyuziv tavsiflovchi raqamli iqtisodiyot: birinchi yondashuv "klassik" deb nomlanib, klassik misollar - teletibbiyot, masofaviy ta'lim, dori-darmonlarni sotish (filmlar, televizorlar, kitoblar va boshqalar). Ikkinchi yondashuv: "raqamli iqtisod" ilg'or raqamli texnologiyalardan foydalangan holda iqtisodiy ishlab chiqarishdir. [5] Natija shuni ko'rsatadiki, bu holatda foyda moddiy ishlab chiqarish (sanoat iqtisodiyoti) emas, balki moliya (kapital) emas, balki yangilik sohalari va olimlarning intellekti tomonidan yaratiladi.

Tadqiqotchilar E. Toffler, F. Fukuyama, D. Bell, J. Naysbitt va boshqalar zamonaviy dunyodagi aksariyat rivojlangan mamlakatlar uchun aynan innovatsion iqtisodiyot jahon iqtisodiy ustunligini ta'minlaydi, deb hisoblashadi. Hozirgi kunda AQSh, Germaniya, Yaponiya, Avstraliya, Kanada, Shvetsiya, Finlyandiya, Singapur, Isroil va boshqa mamlakatlar innovatsion iqtisodiyotning rivojlangan venchur biznesi bo'lgan innovatsion iqtisodiyotga ega mamlakatlar qatoriga kiradi. Biz Karl Shvabning quyidagi fikrlariga e'tibor qaratsak texnologiyalar hayotimizni qanday tarzda o'zgartirib boraytganligini va kelajak avlod hayotini qanday o'zgartirajagini tushunib olishimiz kerak, zero ushbu texnologiyalar biz yashayotgan hayotning iqtisodiy, ijtimoiy, ekologik va madaniy sharoitlarini butkul o'zgartirib bormoqda.

Raqamli iqtisodiyotni kim rivojlantiradi? Degan muhim bir savol tug'uladi O'zbekiston Respublikasi Prezidenti huzuridagi Loyiha boshqaruvi milliy agentligi raqamli iqtisodiyotni joriy etish va rivojlantirish sohasida vakolatli organ hisoblanadi. Bundan tashqari Iqtisodiyot, Moliya, Axborot texnologiyalari, Adliya vazirliklari va boshqa qator davlat tuzilmalari raqamli iqtisodiyotni rivojlantirish uchun o'ziga xos mas'uliyat va vazifalarga ega. Bu haqida Prezident Shavkat Mirziyoyevning Oliy Majlis Senati va Qonunchilik palatasiga qilgan Murojaatnomasida ham alohida ta'kidlab o'tildi. o'z o'rnida qayd etish lozimki, mamlakatimiz hayotida raqamli iqtisodiyotning ayrim elementlari allaqachon muvaffaqiyat bilan faoliyat ko'rsatmoqda. Jumladan, hujjatlar va kommunikatsiyalarning ommaviy ravishda raqamli vositalarga o'tkazilishini hisobga olib, elektron imzoga ruxsat berish, davlat bilan muloqot qilish ham elektron platformalarga o'tkazilmoqda [6].

Har xil yashirin va xufiyona iqtisodiyot mavjudligiga dastlab 20-asrning 30-yillarida e'tibor bera



boshladilar. 20-asrning 70-yillaridan boshlab xufiyona iqtisodiyotni ilmiy tadqiq qilish boshlandi. Xufiyona iqtisodiyotni tahlil qilish rivojlanayotgan mamlakatlar misolida ingliz sotsiologi K.Xart tomonidan birinchilar qatorida boshlandi U “uchinchi dunyo” mamlakatlarida ko‘plab shaharliklarning rasmiy iqtisodiyotga aloqador emasligini aniqladi. U norasmiy iqtisodiyot atamasini ilmiy muomalaga kiritdi. Daromad olishning formal va noformal shakllari o‘rtasidagi farq ish haqi va o‘zini o‘zi ish bilan band qilish asosida topilgan daromad o‘rtasidagi farq sifatida izohlandi. P.Gutman (AQSh) xufiyona iqtisodiyot ko‘lamiga va rolga e‘tibor qilish lozimligini asosladi. Fernando de Soto “Boshqa yo‘l” asarida xufiyona iqtisodiyotni xalqning korrupsiyalashgan davlatning qashshoqlashayotgan aholining asosiy ehtiyojlarini qondirishga layoqatsizligiga nisbatan ijodiy reaksiyasi (javobi) deb atadi. U harajatlarini oshkoralik (legallik) va nooshkoralik (nolegallik) kriteriyalari asosida guruhlashni taklif etgan. 20-asrning 70-yillar ikkinchi yarimi 80-yillarning boshlarida rivojlangan mamlakatlar olimlari va siyosatchilari amaldagi iqtisodiyot ko‘lamlari rasmiy iqtisodiyot ko‘lamlaridan ortiqroq ekanligini aniqladilar.

Xufiyona iqtisodiyot rivojlanishi, birinchi navbatda, davlat tomonidan iqtisodiyot tartibga solinishiga javoban paydo bo‘lgan munosabat sifatida qabul qilinishi kerak. Tartibga solish jarayoni cheklovlarsiz bo‘lmaydi, cheklovlarni puxta o‘ylamay joriy etish ularga amal qilmaslikni yuzaga keltiradi, ayniqsa, buning oqibatida biron naf ko‘rish mumkin bo‘lsa. Xufiyona iqtisodiyotning ko‘p turlari (masalan, soliq to‘lashdan bosh tortish) davlat tomonidan tartibga solish jarayonidagi kamchiliklar sababli yuzaga keladi, masalan boshqaruvning byurokratlashtirganligi, soliq stavkalari yuqoriligi va h.k. Xufiyona iqtisodiyotining rivojlanishi, bir tomondan, davlatning aralashuvi haqiqatiga munosabatdir. Cheklovlarsiz tartibga solish mumkin emas va asossiz cheklovlar ularning buzilishiga sabab bo‘ladi [8]. Agarda biz ushbu muammo yokida ziddiyatiga yechim topmas ekanmiz vaqt o‘tib yaxshi bo‘lmagan oqibatlarni keltirib chiqarishi mumkin, biz raqamlashtirilgan raqamli iqtisodiyot, raqamli shaffof elektron tizimni joriy etish ushbu muammoni chetlab o‘tish uchun eng yaxshi vosita deb hisoblaymiz.

Raqamli texnologiyalar nafaqat mahsulot va xizmatlar sifatini oshiradi, balki ortiqcha harajatlarni kamaytiradi. Qolaversa, bu korrupsiyaga va xufiyona iqtisodiyotga qarshi kurashish uchun samarali vositadir. Buni barchamiz teran anglab olishimiz darkor. Davlat boshqaruvi va ijtimoiy sohada ham raqamli texnologiyalarni keng joriy etib, natijadorlikni oshirish va bir so‘z bilan aytganda odamlar turmushini yaxshilash ularga yetarlicha qulaylik yaratish demakdir.

Buning uchun biz raqamli iqtisodiyotda ishlashga qodir kadrlarni tayyorlash jarayonini tashkil etib mukammal qilib shakllantirishimiz lozim.

Xulosa

Xulosa qilib aytganda, iqtisodiyotda raqamlashtirish jarayonlarini amalga oshirish ehtiyojdan kelib chiqqan holda jadallashtirish talab etiladi. Raqamli texnologiyalar AKT sektorida ustuvorlik kasb etishidan tashqari, iqtisodiyotning boshqa tarmoq va sohalarida ham an‘anaviylikdan voz kechib, raqamli texnologiyalarni joriy etishga ustun darajada ahamiyat qaratilmoqda. Iqtisodiyotni raqamlashtirish jarayonlarini tog‘ri tashkil etish, tarmoq va sohalarda raqamli transformatsiyalashgan iqtisodiyotni kengaytirishda xizmatlar sohasini raqamlashtirish mehnat bozorida o‘zgarishlarni keltirib chiqaradi. Xizmat ko‘rsatish sohasida mehnat bozorining tuzilishi ham o‘zgarib bormoqda, ayrim kasblarning yo‘qolib borishi va yangi kasblarning paydo bo‘lishi bashorat qilinmoqda. Raqamli xizmat ko‘rsatish iqtisodiyotida ishlash uchun yangi kognitiv, ijtimoiy xulq-atvor va raqamli ko‘nikmalar talab qilinadi. Ular raqamli iqtisodiyotda ishlashga qodir kadrlarni tayyorlash jarayonida shakllanishi lozim. Raqamli iqtisodiyot katta hajmdagi axborotni qayta ishlashga asoslanganligi sababli, xodimlarning raqamli kompetensiyalari, xavfsizligi, ishonchliligi, katta hajmdagi axborotni uzoq muddat saqlashi alohida ahamiyat kasb yetadi. Ushbu imkoniyatlardan samarali foydalangan holda, sohani raqamlashtirish va uni yanada takomillashtirish yalpi hududiy mahsulotning oshishiga, ishsizlikning qisqarishiga, aholi turmush darajasining yaxshilanishiga zamin yaratadi.

Adabiyotlar

1. O'zbekiston Respublikasi Prezidentining "O'zbekiston Respublikasida raqamli iqtisodiyotni rivojlantirish chora-tadbirlari to'g'risida"gi qarori. Toshkent sh. 2018-yil 3-iyuldagi PQ-3832 sonli.
2. "Sanoat va xizmat ko'rsatish sohasining raqamli transformatsiyasi, tendensiyalar, boshqaruv, strategiyalar" Xalqaro ilmiy-amaliy anjuman materiallari to'plami.
3. Shukurullo Yo'ldoshmaxmudov Xurshid o'g'li. "Raqamli iqtisodiyot bugungi kunda" Farg'ona Politexnika Instituti Iqtisodiyot yo'nalishi 3-kurs talabasi.
4. Sultonova, M. A. (2021). Mas'uliyati cheklangan jamiyatlarda buxgalteriya hisobini tashkil etish masalalari. Scientific progress, 608-613.
5. Shukurullo Yo'ldoshmaxmudov Xurshid o'g'li. "O'zbekistonda raqamli iqtisodiyotni rivojlantirish Farg'ona Politexnika Instituti Iqtisodiyot yo'nalishi 3-kurs talabasi.
6. Raxmonqulov Jonibek Murotovich. "Raqamli iqtisodiyot sharoitida sanoat korxonalarini va mamlakat innovatsion faoliyatini axborot texnologiyalari asosida samarali rivojlantirish", Toshkent davlat texnika universiteti mustaqil tadqiqotchi doktoranti.
7. <https://cyberleninka.ru/article/n/yangi-innovatsion-texnologiyalar-yo-nalishlari-muommolari-va-yechimlar/viewer>.
8. Abulqosimov H.P. Muminov N.G. "XUFIYONA IQTISODIYOT" Mirzo Ulug'bek Nomidagi O'zbekiston Milliy Universiteti o'quv qo'llanma [7-23].



THE APPLICATION OF DIGITAL MARKETING STRATEGIES

Abstract: The application of digital marketing strategies has become an indispensable component of contemporary business practices, as organizations strive to navigate the complexities of the digital landscape. In this era of rapid technological evolution and changing consumer behaviors, digital marketing serves as a dynamic and adaptive toolset for engaging audiences, expanding market reach, and driving business growth. This abstract provides a succinct overview of the multifaceted role that digital marketing plays in the modern business environment.

Keywords: digital marketing, marketing strategies, online presence, audience targeting, real-time marketing, social media marketing, search engine optimization (SEO), cost-effectiveness, measurability, brand building



Author

Abdulakhatov Muzaffarjon

Department of Digital economy and information technologies, Tashkent State University of Economics,

Tashkent, Uzbekistan;
muzaffar.abdulakhatov@gmail.com



Copyright: © 2024 by the authors.

This article is an open access article distributed under the terms and conditions of the Creative Commons Attribution (CC BY) license (<https://creativecommons.org/licenses/by/4.0/>).

Introduction

In today's dynamic business landscape, the application of digital marketing strategies has become paramount for organizations aiming to thrive in the digital age. As technology continues to advance and consumer behaviors evolve, traditional marketing methods are gradually giving way to more agile, targeted, and measurable digital approaches. Digital marketing involves leveraging online platforms, tools, and technologies to connect with audiences, build brand presence, and drive business growth. This transformational shift has redefined how businesses engage with their target market, emphasizing the need for a strategic and integrated approach to online marketing.

Theory.

The scope of digital marketing is vast, encompassing various channels such as search engines, social media, email, content marketing, and more. This multidimensional approach enables businesses to not only reach a global audience but also to tailor their messages to specific demographics, interests, and behaviors. The real-time nature of digital marketing allows for immediate feedback, fostering interactive communication and enabling businesses to adapt swiftly to changing market dynamics.

Moreover, the cost-effectiveness and measurability of digital marketing strategies provide businesses with a level of control and transparency that was previously unimaginable. Through analytics and key performance indicators, organizations can assess the impact of their campaigns, optimize their strategies on the fly, and allocate resources more efficiently. This data-driven decision-making process is a cornerstone of successful digital marketing endeavors.

Beyond mere promotional efforts, digital marketing plays a pivotal role in shaping brand perception and managing online reputation. Establishing a robust online presence is not just about visibility but also about building meaningful connections with the audience. Social media platforms, for instance, offer a two-way communication channel where businesses can engage directly with consumers, address concerns, and cultivate brand loyalty.

Digital Marketing Strategy - a step-by-step plan formulated to achieve specific goals (promotion of a brand or goods and services) using digital technologies (mainly through Internet channels). It is an integral part of digital marketing and one of the types.

Main part

The most objective of an advanced technique is to oversee client connections and, as a result, accomplish most extreme trade success.

Unlike the IT strategy, which is completely focused on the development of information technology in the company (in particular, technical equipment and staffing), the digital strategy is fully related to marketing tools and focuses on specific goals:

- make the brand recognizable;
- increase loyalty;
- achieve high KPIs in a short time;
- achieve sales growth;
- expand your target audience, taking into account the budget and available resources.

Consider how it is currently being used by the Ajoyib Distribution and other international companies.

Ajoyib group distribution in Uzbekistan works on Zoho platform. This is the most effective when it

combines data from firm sources that are internal to the organization, such as financial and operations data, with data derived from the market in which a company works (internal data). When internal and external data are merged, they can paint a full picture that, in turn, produces a "intelligence" that cannot be obtained from any one piece of data alone. Business intelligence technologies enable firms to, among other things, obtain insight into new markets, evaluate the demand for and acceptability of goods and services for various market segments, and measure the effectiveness of marketing initiatives. Data from a data warehouse (DW) or a data mart is used by BI applications.

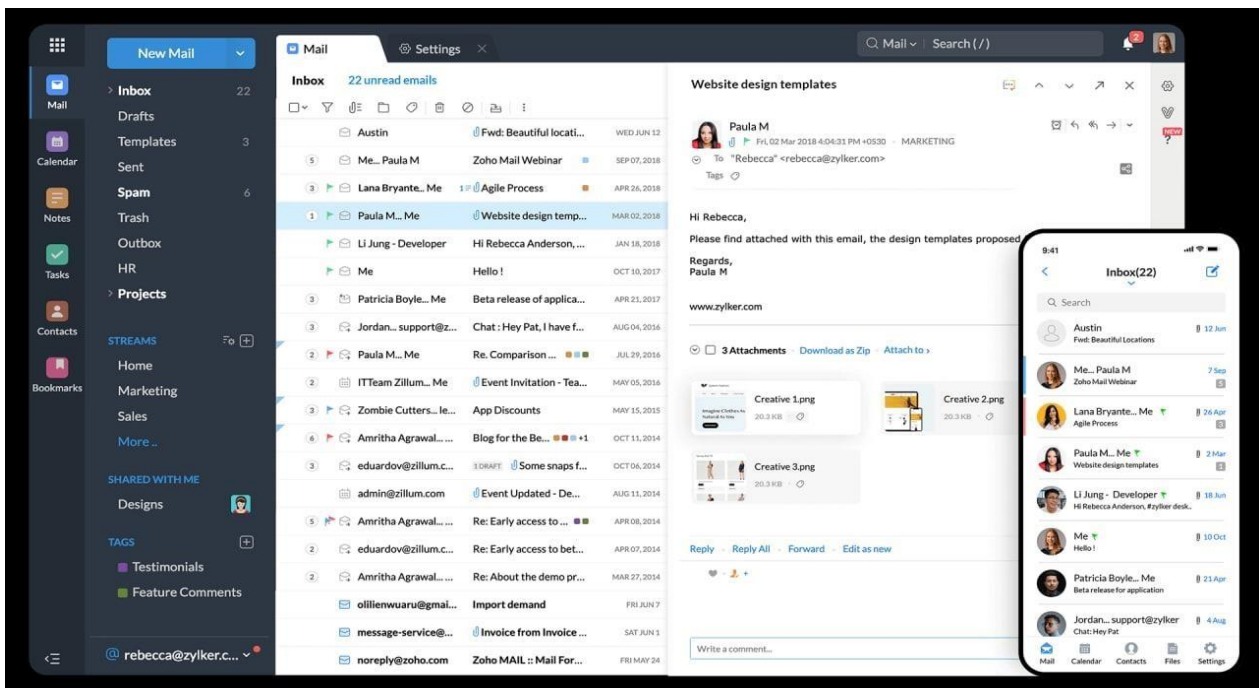

Figure 1. Ajoyib group Distribution platform

Ajoyib group distribution in Uzbekistan uses a Microsoft CRM, system which helps to make work efficient and effective. This is an international network of over 250,000 businesses in 180 countries rely on the award-winning a Microsoft CRM, to convert more leads, engage with customers, and increase revenue. Ajoyib group distribution in Uzbekistan sales, marketing, and customer support activities can all be found in one place with the help of a Microsoft CRM, which also streamlines Ajoyib group distribution in Uzbekistan procedures, policies, and workforce onto a single platform. a Microsoft CRM, is easily adaptable to the unique requirements of any size and type of business. Start-ups, major corporations, and verticals like real estate, healthcare, insurance, legal, media, restaurants, travel, banking, tax, freelancers, and non-profits use contemporary CRM systems like a Microsoft CRM, to improve their sales, marketing, and customer support activities (Fig.1).

Unilever's digital marketing strategy. Each brand uses different digital marketing strategies such as Unilever aims to be faster, simpler more consumer and customer centric, and future ready for the connected world. As a part of this, the company is accelerating its digital transformation end-to-end – from manufacturing and innovation, to marketing and selling – to make Unilever more competitive in an increasing digitized world.

According to Jane Moran, chief information officer, "What is transformative is the way we are connecting people, making data accessible to a broader employee base, and giving them the skills to analyze the data to make better informed decisions. This will help to increase an efficiency of business, also it has an impact on topics that are central to our business, like sustainability."

The thrust toward advanced is somewhat to overcome advertise challenges confronted by all customer products companies, counting need of development within the nourishment trade, the impact of powerless monetary standards in rising markets and the weight to pull in millennials who prefer Facebook, Twitter and YouTube rather than print, radio and TV. In 2018, Unilever propelled an advanced change program over all angles of esteem chain. The company has 30 stages which control it's trade utilizing advanced innovations) Fig.2).

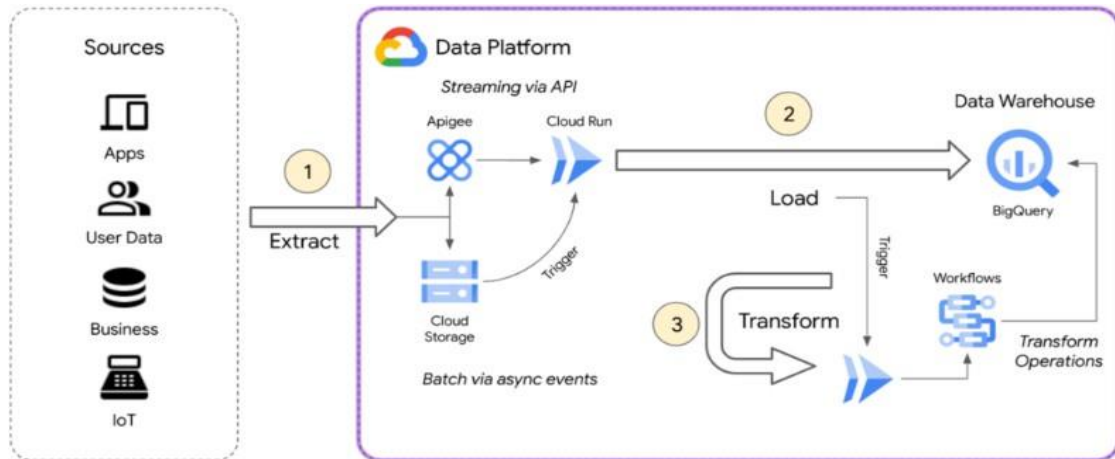

Figure 2. Unilever's digital marketing strategy

By April 2019, Unilever had mechanized over 700 forms in operations – sparing time and diminishing taken a toll. It preparing programs are centering on computerized up-skilling of its individuals.

In the Figures 3 and 4 it can be seen how Google Cloud has been essential in helping Unilever achieve its objective of building 1 billion one-to-one relationships with its customers. Unilever has been able to produce insights more quickly and comprehend customer demands on a deeper level by combining a wide range of consumer data with Google Cloud AI technologies like translation, visual analytics, and natural language processing (NPL). Unilever examined user-generated content related to the campaign hashtag and Valentine's Day using Google Cloud's Cloud Vision API. During the campaign on Instagram, Facebook, and YouTube, six-second bumper advertisements were created using these findings. To keep track of online comments regarding the campaign and advertisements, the company employed Natural Language API. Unilever was able to fine-tune the message delivery of the advertisements that connected with their audience on various social media channels as a result. Nearly 500 million people were affected by the campaign, which improved brand awareness and consideration.



Figure 3. Unilever’s presence in Instagram



Figure 4. Unilever’s presence in Facebook

Nivea’s digital marketing strategy. Nivea has been working on digitalization of promotion over the many decades and this brand was working on growing online presence in all digital platforms, building relationships with consumers, expanding social media communication, introducing cosmetic market to Nivea’s skincare products, maintain a large share of the cosmetic market, increasing sales by support of digital platforms and increasing site traffic of visitors to increase loyalty of the brand from customers (Fig.5).

Nivea’s target market is young professional women and men, who seek innovative high quality skincare products. Nivea aims to expand its online presence and followership to increase brand awareness and loyalty in a high competitive market. Surely, here has big portion of role of digital marketing because 21st century generation became more and more digitalized and it is impossible to deny the fact this fact. Nivea has an excellent digital marketing plan and a well-built social media presence in addition to actively branding their products on television. Nivea has always created its products with the intention of mass marketing them, with various options for various customer types and making them accessible in smaller to big SKUs (stock keeping units).

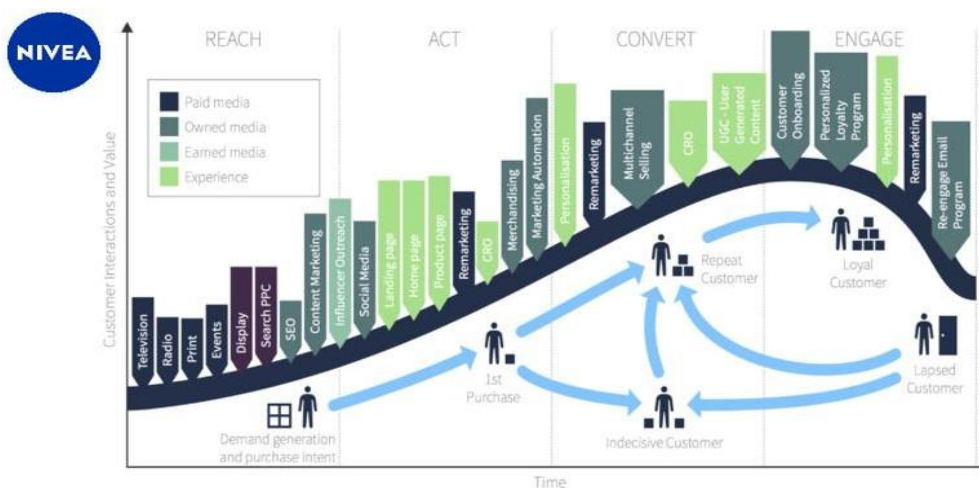

Figure 5. Nivea’s digital marketing strategy

In the picture two, the researcher has showed stages of digital marketing in Nivea the four stages of a strategic digital marketing planning process are plan, reach, act, convert, and engage, and Nivea uses them all. For Nivea to employ digital marketing media, technology, and data to enhance leads and sales, omni-channel planning opportunities include personalizing analytics, setting up KPI dashboards, and creating SMART objectives. Increase Nivea's consumer base and brand recognition to strengthen its marketing funnel. Information on Nivea's digital marketing strategy, which uses the most recent and effective online marketing tactics to increase site traffic. In order to produce leads for the future, it promotes interactions on its website or social media. It reaches its target, thus it's critical that you impact their subsequent actions as they go down the sales funnel toward a choice to make a purchase in a physical store or online. Of course, increasing consumer conversion is the ultimate goal of Nivea's structured digital marketing plan. Retargeting, nurturing, and conversion rate optimization are used to remind and convince their audience to buy online or offline, depending on how significant phone and in-person channels are to the target demographic. Nivea's efforts finally pay off as it raises sales from repeat consumers by keeping them interested after their initial purchase. the creation of hyper-personalized marketing strategies employing online, email, and social media marketing to enhance individualized communications Nivea’s presence in Instagram and website are in the following figures 35,36.

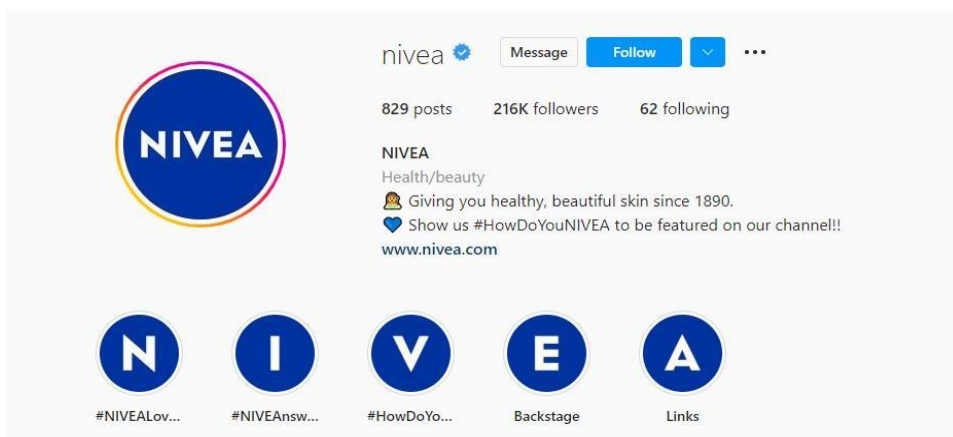

Figure 6. Nivea’s website

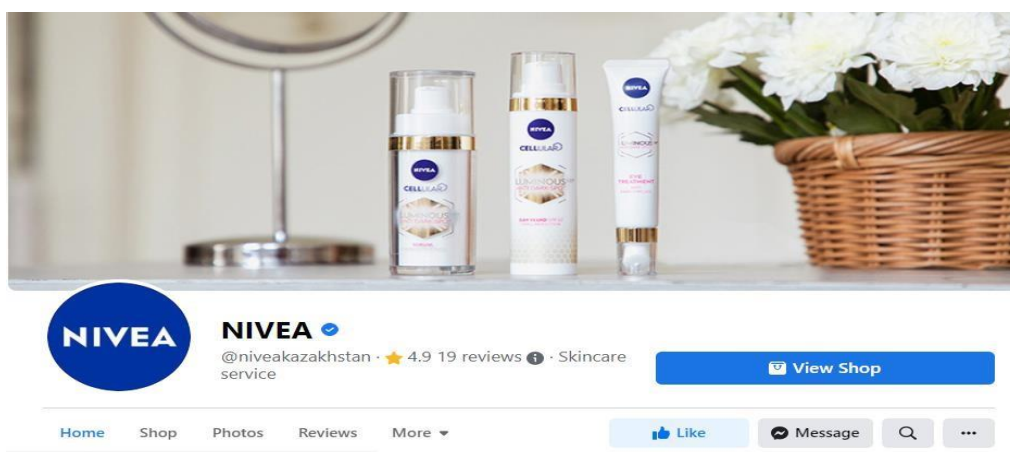

Figure 7. Nivea’s presence in Facebook

Danone Nutricia’s digital marketing strategy. Nutricia is a Danone brand that specializes in restorative nourishment and newborn child products, counting therapeutic sustenance for babies with particular needs. Ajoib Group Distribution in Uzbekistan imports following brands:

Nutrilon products: Nutrilon Pronutra Advance, Nutrilon PeptiGastro, Nutrilon Antirefluks, Nutrilon LactoseFree, Nutrilon Hypoallergy, and Neocate.

Malyutka: Malyutka Gold and Malish infant milk powder products for newborn babies.

This brand extremely active in digital marketing and applies marketing mix strategies in digital very effectively. Nutricia has divided its products into to category and does digital marketing strategy separately for instance Nutrilon products are in the market in premium product segment and Malyutka is much more economy product segment. It has two different tactics for its products. It created a website which teaches to young mothers during their pregnancy period and after pregnancy periods as well and called this website as a NutriciaClub and in this club active more than 12 thousand of moms and they daily share information with their internal networks. NutriciaClub started new startup project in Uzbekistan and it calls baby poop-checker with it mothers can check the health of their babies by digital health analyses and it works so efficient that many mothers use this platform and shares with their relatives about baby’s health (Fig. 7-8).



Figure 8. Danone Nutricia's digital marketing strategy

There are two ways of checking the babies poops digitally first is a manual stool test and second is checking stool with artificial intelligence. In a manual stool test, parents can use the settings (sliders) to select the color and consistency that is considered normal for a baby's stool. This method involves subjective judgment and is dependent on the parent's ability to accurately assess the visual characteristics of the stool. The manual stool test is a traditional approach that relies on visual inspection and parental experience.

Conclusion.

In conclusion, the application of digital marketing strategies stands as a cornerstone in the contemporary business landscape, offering a transformative and dynamic approach to reaching and engaging with target audiences. As technology continues to advance and consumer behaviors evolve, businesses are compelled to embrace digital channels and tactics to remain competitive and relevant.



Adabiyotlar

1. Decree of the President of the Republic of Uzbekistan dated February 28, 2023 No. PF-27 “New Development Strategy of Uzbekistan for 2022-2026”. Tashkent city, 2023.
2. Weber, C. (2018): ‘What are the Disadvantages of Digital Marketing?’ (Content Marketing Institute 2016) (Quick Sprout 2016).
3. Alshaketheep, K. M. K. I., Salah, A. A., ALOMARI, K. M., KHALED, A., & Jay, A. A. A. (2020). Digital Marketing during COVID 19: Consumer’s Perspective. WSEAS Transactions on Business and Economics, 831-841.
4. Bala, M., & Verma, D. (2018). A critical review of digital marketing. M. Bala, D. Verma (2018). A Critical Review of Digital Marketing. International Journal of Management, IT & Engineering, 8(10), 321-339.
5. Bhandari, P, (2020): ‘An introduction to quantitative research’ BrightEdge Channel Report (2019): ‘Organic Search Improves Ability to Map to Consumer Intent’” (Iskandar & Komara, 2018).
6. Buttle, F. (2009). Customer relationship management: concepts and technologies. Butterworth-Heinemann Ltd. ISBN 9781856175227
7. Cyber Planet (2019): ‘Top disadvantages of digital marketing’ Abdulakhatov M. M, “The main impacts of digital transformation on small to medium-sized business enterprises” Scientific electronic journal of Digital Economy and Information Technologies No. 2, 2022
8. Abdulakhatov M. M “The digital economy is the basis for economic development” Scientific journal of Economy and Society No. 10, October 7, 2022
9. Kobilov A.U, Abdulakhatov M.M, Rajabov Sh.B, “Artificial intelligence as a technological innovation for economic development of the republic of Uzbekistan” ICFNDS ’22, December 15, 2022, Tashkent, TAS, Uzbekistan.



Author

Dadabayeva Ra'no

Department of Digital economy and
information technologies, Tashkent
State University of Economics,

Tashkent, Uzbekistan;
dadabayeva.rano@gmail.com

THE EFFECTS OF DIGITAL MARKETING ON A COMPANY'S OVERALL COMMERCIAL GROWTH IN UZBEKISTAN

Abstract: In the contemporary business landscape, digital marketing has emerged as a pivotal tool for companies striving to enhance their commercial growth. This study investigates the effects of digital marketing strategies on the overall commercial expansion of companies operating in Uzbekistan. Through an in-depth analysis of digital marketing practices and their correlation with business growth metrics, this research aims to provide insights into the efficacy of digital marketing initiatives in the Uzbek market context. Employing a mixed-methods approach, this study incorporates both quantitative analysis of key performance indicators and qualitative examination of digital marketing strategies adopted by companies in Uzbekistan. By surveying a diverse range of businesses across various industries, this research seeks to identify the most impactful digital marketing tactics and their contribution to commercial success. The findings of this study are expected to contribute significantly to the understanding of how digital marketing influences commercial growth in Uzbekistan. By shedding light on the effectiveness of different digital marketing channels, platforms, and techniques, this research will offer actionable recommendations for companies seeking to optimize their digital marketing efforts and capitalize on the opportunities presented by the digital era.



Copyright: © 2024 by the authors.

This article is an open access article distributed under the terms and conditions of the Creative Commons Attribution (CC BY) license (<https://creativecommons.org/licenses/by/4.0/>).

Keywords: Digital marketing, commercial, innovation, technology, economy, commercial growth, Uzbekistan, business strategy, marketing effectiveness



Introduction

The world is evolving constantly, and this has an impact on how we perceive time. There are no longer isolated regions of the globe, and visiting relatives, meeting people, or waiting for a message no longer require months-long trip. Accessing the Internet only requires a few quick clicks to complete everything. The Internet, a well-known "substance" that has been seamlessly incorporated into modern society like mushrooms and tree roots, has undoubtedly benefited all players in this game. It is difficult to pinpoint exactly what occurs in the world of numbers, but it alters reality and makes time fly.

The internet and online purchasing have expanded the possibilities of marketing and given rise to new sectors, tactics, and varieties of it. Here is where digital marketing expanded to include not just television and radio but also the online environment, which is brimming with clever and practical promotional techniques that are currently in use. Even more so, it produced a highly competitive climate for businesses vying for web leadership.

Statement Of The Research Problem

Four research questions were developed to serve the needs of this study. The study's focus on digital marketing is covered through three research questions. The final inquiry should address the subject of the business mentality and culture.

This set of questions included four survey questions. Then, respondents were prompted to list the most crucial goals of their own companies. They were then asked to assess their general job happiness and the working habits of their coworkers and employees. They were then asked to rank the business priorities of their respective organizations in order of importance. They were then asked to rank how crucial it is for them to stay one step ahead of the competition.

How much of an effect does digital marketing have on a company's growth in Uzbekistan? This group of questions tries to prove that digital marketing has positively affected the business development of Uzbekistan companies. The participants were questioned if they agreed that digital marketing played a role in the performance of their businesses and whether the outcomes achieved via the use of digital marketing met their expectations.

This set of inquiries aims to demonstrate how the growth of Uzbekistani businesses has been positively impacted by digital marketing. The participants were questioned if they agreed that digital marketing played a role in the performance of their businesses and whether the outcomes achieved via the use of digital marketing met their expectations. In addition, they were asked if they preferred traditional marketing techniques to digital ones and, if yes, to briefly explain their choices. The most popular digital marketing channels employed by Uzbekistani businesses were then examined.

Respondents were questioned about the digital marketing channels their businesses use and which ones they believe to be most successful in order to learn which ones are most popular among Uzbek enterprises. They also had to say which of the digital marketing objectives meant the most to them. Next, they were asked to rank the importance of the elements on their website.

The final set of questions focused on the financial elements of digital marketing in the participants' organizations. Companies were prompted to disclose the proportions of their digital marketing budgets (% of marketing budget) and marketing budgets as a percentage of revenue. They were also questioned if their spending for digital marketing had grown over the previous three years. Finally, they were questioned about whether the COVID-19 outbreak will affect their digital marketing budget.

The next section of the study focused on how digital marketing affects business performance. In this portion, respondents were required to analyze advanced showcasing methodologies in their companies. Firstly, they were inquired in case they concur that executing advanced promoting had a

positive impact on their companies' victory. As can be taken note from the figure 1, that 80% of the respondents accept that advanced promoting contributed to their companies' victory. 17% of them are impartial, which suggests they are not persuaded on the off chance that that's the case, whereas as it were one member considers that advanced promoting was not a vital calculate contributing to their company's victory.

Besides, members were inquired to appraise in case computerized showcasing techniques met their criteria, or on the off chance that it did not provide anticipated comes about. It can be watched from the figure 2 that 36.7% of the respondents accept that computerized promoting techniques conveyed comes about that were anticipated, whereas 56.7% of members see room for advancement as the comes about conveyed did not meet criteria totally.

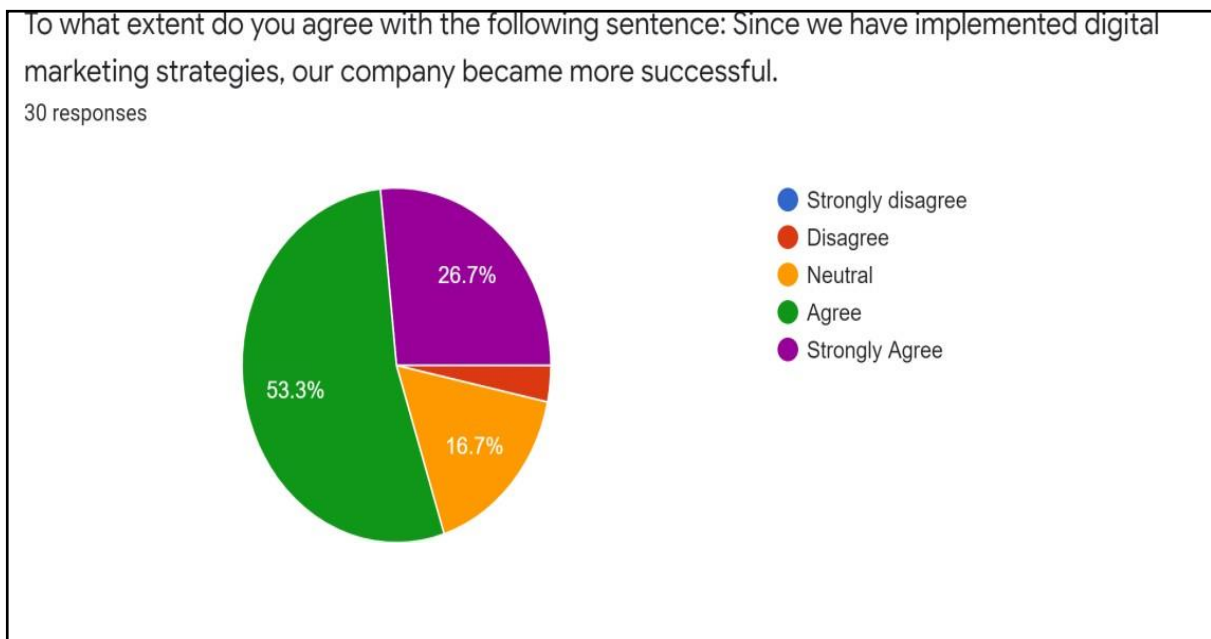

Figure 1. Impact of digital marketing on business success

As it were two respondents consider comes about conveyed by executing advanced promoting methodologies to be not great sufficient, not as anticipated.

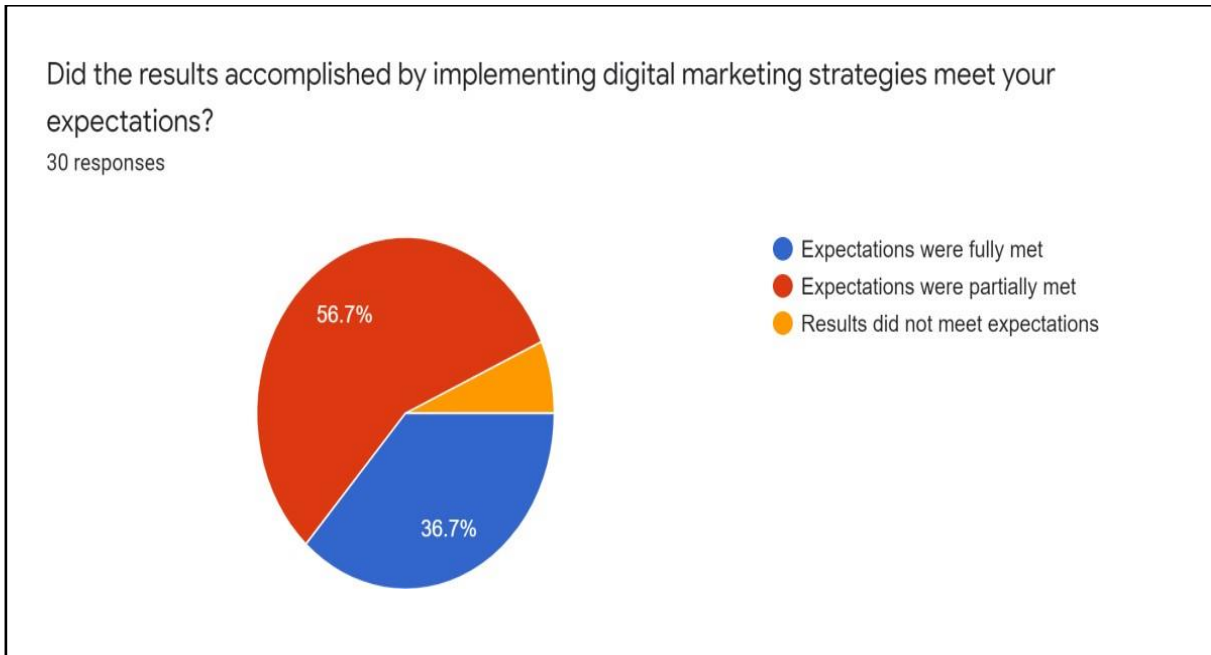

Figure 2. Analyzing the outcomes produced by utilizing digital marketing tactics

At long last, respondents were required to choose on the off chance that they favor conventional showcasing strategies to computerized promoting strategies, and in that case, they were inquired to clarify their choice. As can be famous from the figure 3, 4 members incline toward advanced showcasing strategies to conventional promoting strategies, and 7 of them favor conventional promoting strategies. Here are a few of the clarification to why certain members lean toward conventional showcasing methods:

- “Because my target demographic isn't very web-savvy at the moment, I rely more on the personal contacts I've developed throughout my time in the industry.”
- "Advanced marketing is more confusing,"
- "Because those kind of displaying make me more recognizable." methods

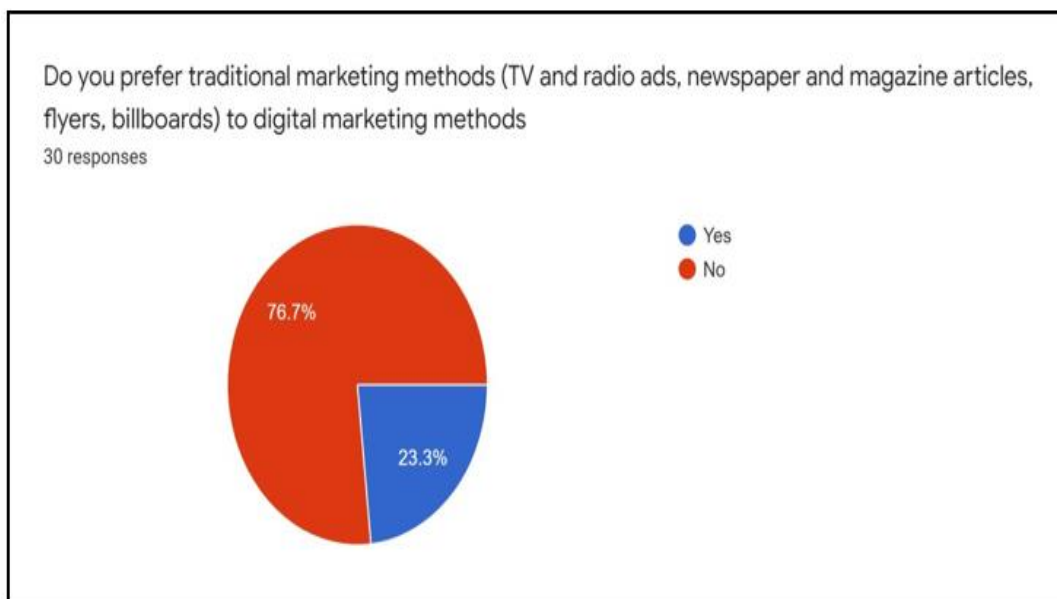

Figure 3. Respondent distribution based on their marketing preferences

To conclude, most of the members think that executing computerized showcasing procedures in their companies' is a vital figure for commerce victory. Also, most of them lean toward advanced showcasing strategies to conventional showcasing strategies, which is in understanding with the desires since we live in an advanced time. At long last, members accept there's more room for advance as the lion's share feels that computerized promoting did not in full meet their expectations. It was exceptionally curiously to know what was the foremost successful advanced promoting channels. In this portion of the study, respondents were inquired to analyze which of the advanced promoting channels are most compelling for their companies. To begin with of all, they were required to choose which of the taking after computerized showcasing channels their companies utilize (figure 4).

Social media showcasing is utilized in 80% of the companies taking an interest in this investigate. Following most noteworthy spoken to advanced showcasing channel is mail showcasing, with 43.3% utilizing it in their promoting procedure. Paid-per-click publicizing is utilized by 33.3% of the companies, whereas SEO and substance showcasing are spoken to in as it were 26.7% of the companies.

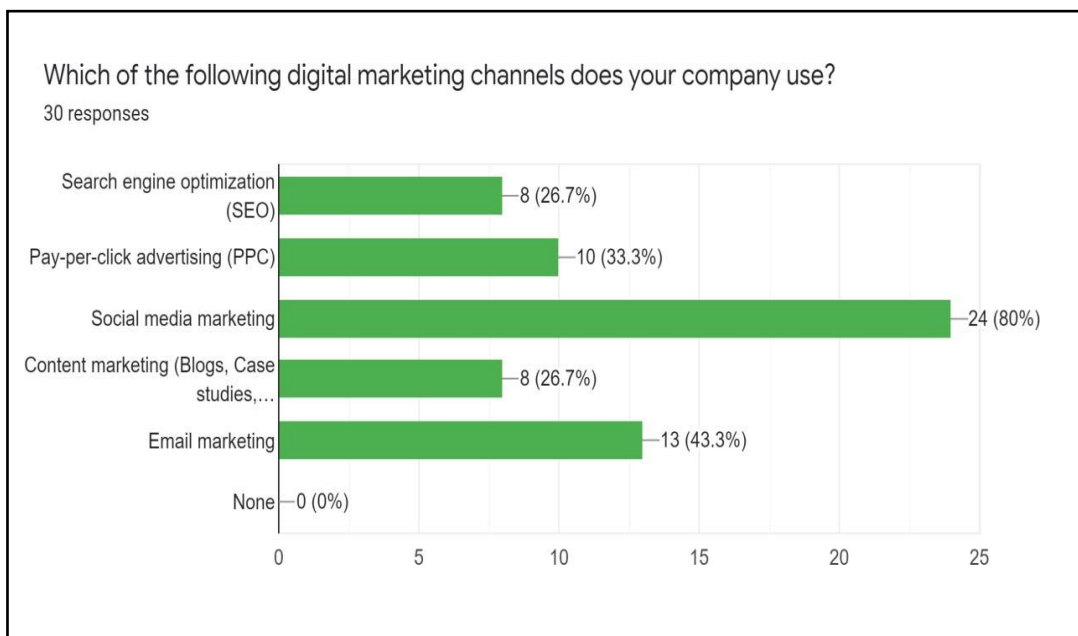

Figure 4. Digital marketing channels' prevalence in respondents' employers

Besides, members were required to uncover which computerized promoting channel had the greatest effect on their companies' deal. From the figure 5, it can be watched that 56.7% of the companies, state that social media promoting has the greatest effect on their deals. 20% that SEO is driving their deals the foremost. 16.7% of them state that mail marketing improves their deals the foremost, whereas as it were two companies recognize PPC as having the greatest effect on their deals.

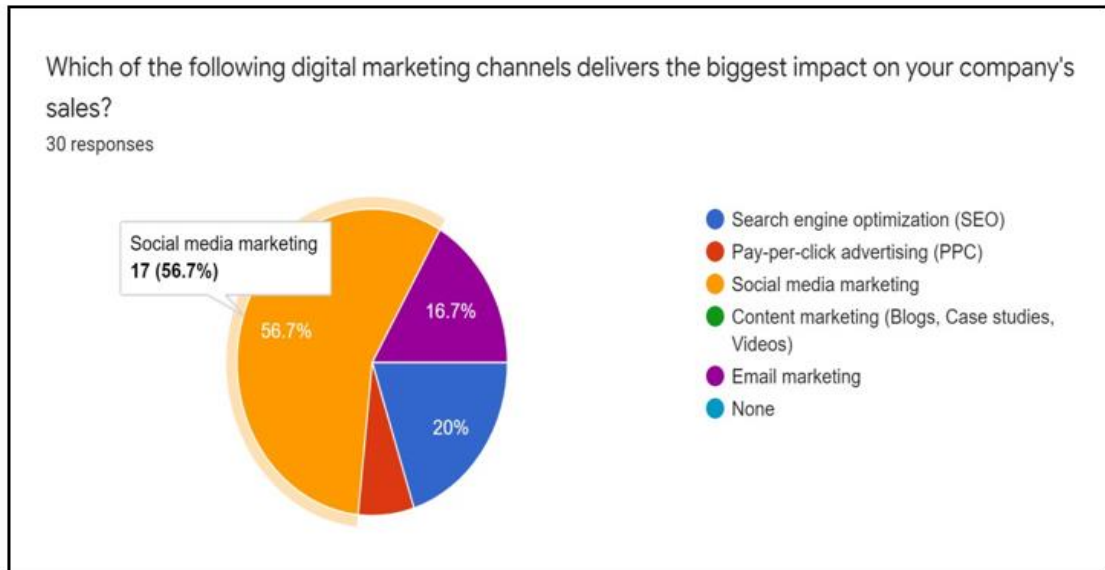

Figure 5. The most effective digital marketing channel for increasing revenue for businesses

Another, as the site may be an exceptionally critical component of computerized promoting, members were inquired to choose two highlights of their websites that they consider to be the foremost critical figure in propelling the clients to purchase the products/service that the company is advertising (Figure 6). Majority of them (66.7%) accept that ease of route of web site is the foremost imperative highlight and 53.3% of them think that it is key to have clear and straightforward item data included on their websites. 33.3% are persuaded that relative and definitive substance on their websites is pivotal, whereas 20% of them accept that it is most important to have social media coordinates on their websites. 16.7% think that site plan is of significant significance, and three companies don't have websites.

At last, respondents were inquired to choose two primary advanced promoting objectives of their companies (figure 7). 63.3% of them state increment in deals income as the most advanced showcasing objective of their company, whereas half of them accept that brand mindfulness is the most objective of their advanced promoting technique. 40% of the respondents recognize increment in lead era as the key objective while 26% state that progressing client involvement is the foremost critical objective.

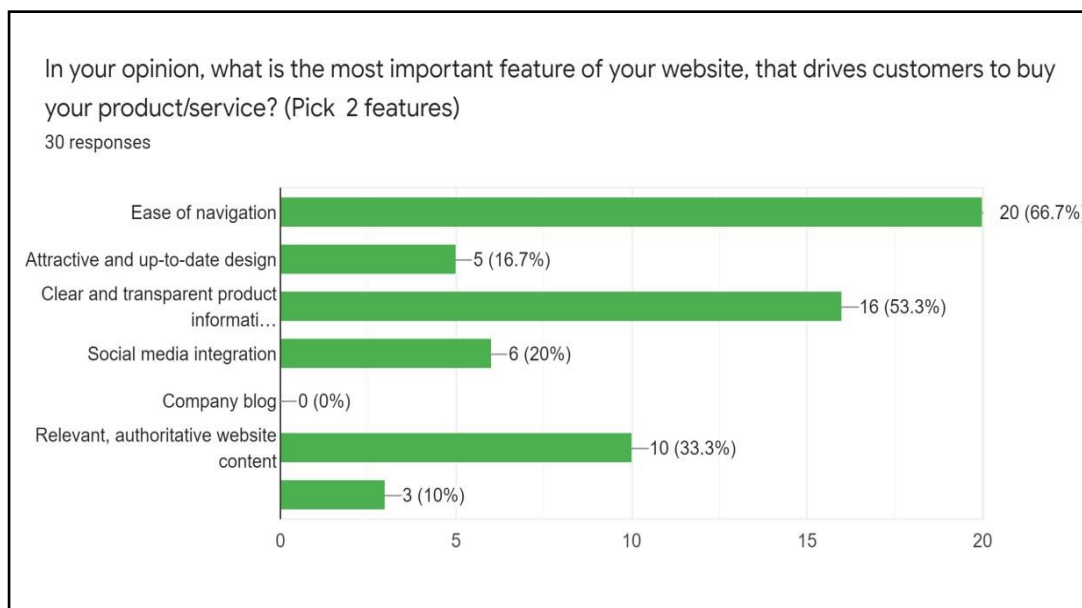

Figure 6. Features of websites that encourage consumers to buy

As it were 13.3% chosen increment in site activity as advanced showcasing objective and 10% picked enhancement in information quality.

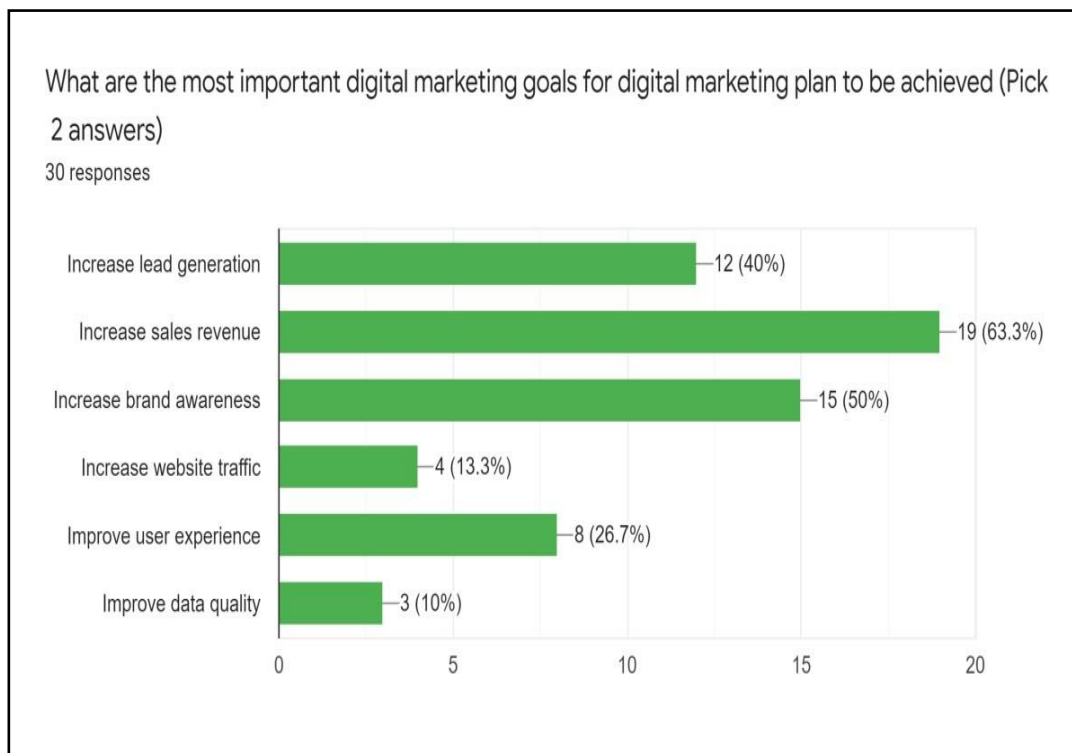

Figure 7. The most crucial objectives for digital marketing

Conclusion

After analyzing this bunch of answers, it can be concluded that social media promoting is the foremost spoken to advanced showcasing channel in Uzbekistan companies, and what is more, social media promoting has the greatest effect on deals, taken after by SEO and mail promoting. At long last, most of the respondents accept that for the site to be effective, it is imperative that the site is simple to utilize and get it, to be straightforward and offer clear product/service data.



References

1. Decree of the President of the Republic of Uzbekistan dated February 28, 2023 No. PF-27 “New Development Strategy of Uzbekistan for 2022-2026”. Tashkent city, 2023.
2. Presidential Decree of the Republic of Uzbekistan of January 28, 2022 No. UP-60 «About the Strategy of development for new Uzbekistan for 2022 – 2026»// <https://lex.uz/ru/docs/5841077>
3. Ashe-Edmunds, S. (2017): ‘The disadvantages of traditional advertising’
4. <https://ahrefs.com/blog/how-long-does-it-take-to-rank/>
5. Weber, C. (2018): ‘What are the Disadvantages of Digital Marketing?’
6. (Content Marketing Institute 2016) (Quick Sprout 2016).
7. Alexander, L. (2020): ‘The who, what, why & how of digital marketing’
8. Cyber Planet (2019): ‘Top disadvantages of digital marketing’
9. Abdulakhatov M. M, “The main impacts of digital transformation on small to medium-sized business enterprises” Scientific electronic journal of Digital Economy and Information Technologies No. 2, 2022
10. Abdulakhatov M. M “The digital economy is the basis for economic development” Scientific journal of Economy and Society No. 10, October 7, 2022
11. Kobilov A.U, Abdulakhatov M.M, Rajabov Sh.B, “Artificial intelligence as a technological innovation for economic development of the republic of Uzbekistan” ICFNDS ’22, December 15, 2022, Tashkent, TAS, Uzbekistan
12. Dawes, J. (2018). The Ansoff Matrix: A Legendary Tool, But with Two Logical Problems. But with Two Logical Problems (February 27, 2018).
13. DeMers, J. 2013. The Top 7 Online Marketing Trends That Will Dominate 2014. Forbes. Published 17.09.2013.
14. Dimitrova, P., & Sin, I. (2018). Digital Marketing in Start-Ups: The role of digital marketing in acquiring and maintaining business relationships

**Author****Ulugbek Narmanov**

Department of Macroeconomics,
National university of Uzbekistan,
Tashkent, Uzbekistan;
economyfinance135@gmail.com,

Guzal Abdishukurova

Department of Macroeconomics,
National university of Uzbekistan,
Tashkent, Uzbekistan;

Correspondence:

abdishukurova.guzal@yandex.ru

THE ROLE AND IMPORTANCE OF THE DIGITAL ECONOMY IN THE LABOR MARKET

Abstract: This article raises the role of the digital economy in the labor market, its development and problems, as well as ways to solve it. The purpose of the study is to examine the impact of the transition to a digital economy on labor. To achieve this goal, methods such as analysis, synthesis, comparison and modeling were used. Digital technologies are boldly entering the everyday life of society and causing unemployment due to the transition to automated systems in enterprises and organizations. Accordingly, the issue of employing the released workforce is becoming more acute, but today there is no strategy for adapting the unemployed. A completely new question arises between digital and socio-economic relations. Calculations showed that an increase in unemployment by 1% would lead to a fall in GDP by 0.54%. The results obtained during the study can be used in further studies of structural (technological) unemployment and labor market problems in the digital economy.

Keywords: Digital economy, labor market, employment, supply and demand in the labor market, new technologies.



Copyright: © 2024 by the authors.

This article is an open access article distributed under the terms and conditions of the Creative Commons Attribution (CC BY) license (<https://creativecommons.org/licenses/by/4.0/>).



Introduction

For each country, macroeconomic stability, ensuring employment and reducing unemployment are the main objectives. In addition, in the 21st century, the digital economy is penetrating all areas and directions. In a certain sense, this affects supply and demand in the labor market. Today, in the conditions of Uzbekistan, it is extremely important to study the laws, trends and possibilities of the development of the digital economy, in particular, the level of penetration of information technologies into various sectors of the economy on a scientific basis. The development and prospects of our country, the success of the reforms being carried out on a large scale in our country directly depend on the introduction of innovations into our national economy. Therefore, it is important to improve the digital economy, to study its economic, political, social and legal foundations from a scientific and practical point of view.

Living in harmony with the world community of Uzbekistan paves the way for the activation of integration and globalization processes. On the one hand, the development of integration processes requires the use of modern ICT, and on the other hand, it has brought about business transformation. Studying these processes from an economic and political point of view and making scientific conclusions is the demand of the time.

Trends towards blurring the boundaries between different types of activities and greater flexibility in operations, globalization and transparency of interaction with counterparties will only intensify in the future. Employees will always be important to organizations, which in turn will go beyond the traditional mode of work organization and full-time work [1].

Uzbekistan may implement the digital economy in the coming years. After all, it is necessary to work with foreign investors who intend to import these innovations as investments. In addition, digitization of the economy is considered one of the most important factors for the development of our country. Therefore, we should be ready to quickly learn new things, think innovatively, use science and technology innovations wisely, and teach our young people modern professions.

In recent years, the digital economy, which is rapidly developing in many countries around the world, has created various challenges as well as opportunities for the social and economic sphere. In such a situation, sectors of national economies are required to adapt to the conditions of the digital economy.

The backbone of the digital economy is the IT sector, but the boundaries of the digital economy are not limited to it and include some emerging digital business models [2].

Main part

In the Development Strategy of New Uzbekistan for 2022-2026, it is planned to make the digital economy the main "driver" of economic development and increase its size by at least 2.5 times. The volume of software production should be increased 5 times, and their export should be increased 10 times to 500 million dollars.

New technologies, especially artificial intelligence, will inevitably lead to significant changes in the labor market, including job losses in some sectors and new opportunities in others on a massive scale. This creates structural unemployment for wage earners. Over a certain period, employees improve their knowledge and skills to learn a new profession. The development of the digital economy excludes labor-intensive types of labor from the labor market and creates new types of labor. The digital economy creates a wealth of new knowledge and skills, mainly new social protection measures and fundamentally new relationships between work and leisure. An innovative education system affects the quality of personnel, and an innovative economy affects unemployment, as does the digital economy.

First, the digital economy is an excellent mediator of educational development, focused not only on the educational process, but also on studying methods for organizing this process, as well as ensuring universal access to educational services throughout life. In order to fully unlock the socio-economic potential of digital technologies and avoid undesirable consequences, it is necessary to strengthen international cooperation as soon as possible. Uzbekistan is at the initial stage of digitalization of the economy. An effective transition requires not only preparing the infrastructure and the state as a whole, but also creating a reliable foundation for ensuring the digital economy and information security of the state. The share of the digital economy in China's GDP is 30%, the UK's share in GDP is 12.5%, and Uzbekistan's share in GDP is less than 1%. Because the old types of work are still preserved in the labor market of Uzbekistan. According to the Information and Communications Development Index, we rank 103 among 170 countries. The problems of developing the digital economy in Uzbekistan are similar to the general problems faced by developing countries.

The role of the digital economy in the economy in determining the competitiveness of countries in the process of globalization is unique. No matter which sector or sector of the economy we look at, we see the place of digital technologies in all of them. From services in the country's banking system, we can see the share of innovative digital technologies at the level of public services. The digital economy is used to represent two different concepts. First, the digital economy is a modern stage of development, which is characterized by the priority of creative work and information benefits. Secondly, the digital economy is a unique concept; the object of its study is the information society. Among the socio-economic problems that emerged or intensified during the formation of the digital economy, which will have a direct impact on the labor market, we will put at the forefront the increase in inequality both between countries and within countries, including countries with developed economies. The digital technology adoption index, as studies conducted by the World Bank show, is directly dependent on the level of economic development, and developed countries and regions primarily receive the main additional resources for growth.

The digital economy is a worldwide network of economic activities, commercial transactions and professional interactions that are supported by information and communication technologies (ICT). It can be briefly described as a digital economy. In its early days, the digital economy was sometimes called the Internet economy, new economy, or web economy due to its dependence on an Internet connection. Modernizing Uzbekistan today is aimed not only at development, but also at becoming one of the strongest countries because of comprehensive reforms implemented in various spheres of society. In the digital economy, information in digital form is the main element of production in all socio-economic spheres, and a gradual transition to such an economic system will further improve the global competitiveness of our country, the quality of life of citizens, create new jobs, create opportunities for rapid economic growth and ensure national independence.

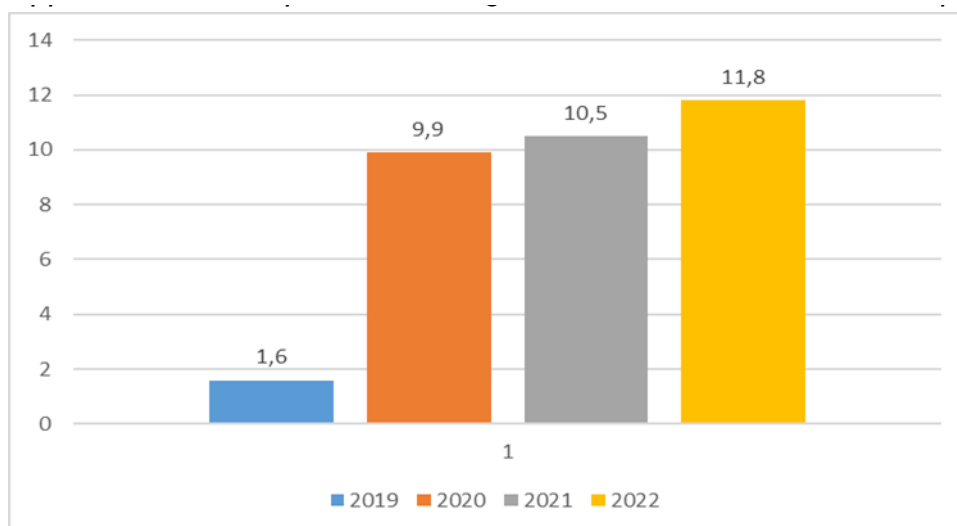

Figure 1. Income of Uzbek freelancers from foreign platforms in 2019-2022 (million US dollars) [3]

Analyzing the income of freelancers in the republic from foreign platforms in 2019-2022, according to the situation in 2022, the income amounted to 11.8 million US dollars, or compared to 2019, income increased by almost 10.2 million US dollars, or 737% increased. The growth rate compared to 2019 is 7.4 percent (Figure 1).

A clear example of the growth of the digital economy in the labor market is freelancing. The basis of Freelancer, which is widely used in our country, is derived from the English word "freelance", which in turn was used for righteous knights who carried swords and spears, slaughtered animals and saved people. Carrying a "Lance", they were "free" and ready to do whatever service they could. Now we have thrown away our swords and spears, and now we are engaged in business and social projects. Our sword is our specialty and our freedom is online platforms.

Based on digital platforms as the main production elements, labor relations and the function of labor are being transformed. The organization of labor is no longer carried out based on hierarchy (mainly vertical division of labor), but because of the integration of resources on the platform within the framework of joint activities. The new labor organization model ensures the integration of interests and mutual benefits based on joint activities. Thanks to data infrastructures, labor, goods and services can be virtual in the exchange process. At the same time, more resources can be attracted to joint activities on the platform, more organizations can be connected (integrated) through virtual access, and industry chains can be extended to create an ecosystem.

According to the study *The Future of Jobs*, by 2025, due to the automation of all spheres of human activity, machines will perform more than half of all work tasks. For comparison, in 2018, 71% of work was performed by human labor, and only 29% of processes were automated. Thus, many professions will cease to exist, but in return, vacancies with fundamentally different qualifications will appear, which will require retraining or advanced training of many employees [4].

The digital economy is characterized by network, social and external cooperation. The fastest growth of online platforms in recent years is in the accommodation and transportation markets, driven by the availability of distributed private assets that can be effectively monetized when supported by digital technologies. There is also an accelerated growth of online platforms and the development of the sharing economy (sharing economy, "mutual aid economy"), in which, instead of purchasing vital goods, people prefer to "share" them with each other. For talented people with outstanding abilities,

the global labor market, thanks to online platforms that erase territorial boundaries, allows them to carry out several projects simultaneously remotely or remotely.

Because of the development of the digital economy in Uzbekistan and the development of technology in the labor market, the creation of jobs through the introduction of new technologies, we need to train future personnel who will meet the requirements of the time.

Labor resources and the situation on the labor market have always played the role of indicators of the stability of society and the development of the state and national economies. The impact of advances in information and communications technology (ICT) on employment and the decline in labor demand is fueling ongoing debate about the disappearance of work, as we know it. However, work activity changes in accordance with economic development trends, which requires a revision of established concepts and definitions. The format of relationships between employees and employers is changing significantly (the share of flexible and remote forms of employment is increasing). The role of intellectual labor is increasing compared to traditional physical labor.

Currently, a variety of terms is used to refer to new trends in employment that are associated with the “erosion” of traditional forms of employment and traditional labor relations: atypical employment, contingent employment, flexible employment, platform employment, temporary work, casual work and non-standard work arrangements. Meaning that not all of these jobs are low skilled.

In the platform economy, the division of labor fundamentally changes. This division of labor occurs through the sharing of data and technical resources to create ecosystems of collaborative activities. Thus, forms of division of labor are based on cooperation, pooling more and better resources on platforms to achieve joint gains, including management efficiency and employment stimulation.

In the digital era, enormous changes are taking place in work activity, employment and forms of labor organization, which bring both risks and new opportunities. People are afraid of being left without work, while at the same time new professions and jobs are appearing, including from the point of view of meaningful activities. The platform economic model in the digital age is the result of the integration of data, technology and industries, bringing changes to the design of work, the content of current work and the nature of the future of work. Collaborative management and empowerment are becoming the basic model of work organization. As data participates in social reproduction as a new factor of production, it becomes central to the infrastructures that support collaborative activities. Objects of labor and work processes are becoming digital, affecting labor costs, distribution, exchange and consumption.

Conclusion

For this, it is necessary to create an electronic national system in Uzbekistan based on South Korea's electronic education system, and through this system, it should be included in pre-school educational institutions, public educational institutions, academic lyceums and higher educational institutions. Because of the development of the digital economy in Uzbekistan, it will contribute to the reduction of unemployment, the emergence of new professions in the labor market, and the increase of tax revenues.

Connecting industry value chains and data has changed the work functions of organizations and promoted employment in the new realities. The main function of labor organization is no longer just vertical management, but expanding opportunities for sharing various resources on a platform to form a single ecosystem of common development.

Thus, there is a transformation of the labor market towards changing requirements for employees related to their personal development and the desire for personal growth, which will allow them to be mobile in a changing economic reality. Thus, it is necessary to focus on the need for high-quality training of qualified personnel in demand in the labor market and the real sector of the economy.



References

1. Filipova I.A. The impact of digital technologies on labor: Guidelines for labor law: Monograph. Nizhny Novgorod: Nizhny Novgorod State University named after N.I. Lobachevsky; 2021. 106 p.
2. Dahlman C., Mealy S., Wermelinger M. (2016) Harnessing the Digital Economy for Developing Countries. Paris: OECD. Available at: <http://www.oecd-ilibrary.org/docserver/download/4adffb24-en.pdf> (accessed 1 June 2018).
3. Digital Economy Research Center of the Republic of Uzbekistan in 2023.
4. <https://www.mckinsey.com>



Mualliflar

Lutfiy Farangiz Sharidin qizi

Raqamli iqtisodiyot va moliyaviy texnologiyalar kafedrası, "University of Management and Future Technologies" universiteti,

Toshkent, 100208, O'zbekiston;

Ismoilova Mohigul

Yusubjon qizi

Raqamli iqtisodiyot va moliyaviy texnologiyalar kafedrası, "University of Management and Future Technologies" universiteti,

Toshkent, 100208, O'zbekiston;

RAQAMLI IQTISODIYOTNI RIVOJLANTIRISH- NING XORIJIY TAJRIBALARI

Annotatsiya: Mazkur maqolada jahon iqtisodiyotining raqamli transformatsiyasi va unda AQSH, Xitoy va Germaniya tajribalari o'rganilgan, shuningdek rivojlangan mamlakatlar tajribalarini O'zbekistonda qo'llash haqida fikr yuritilgan.

Kalit so'zlar: Jahon iqtisodiyoti, raqamli transformatsiya, raqamli iqtisodiyot, YaIM, raqamli texnologiyalar, sun'iy intellekt, kiberxavfsizlik.



Copyright: © 2024 by the authors.

Ushbu maqola Creative Commons Attribution (CC BY) litsenziyasi shartlari asosida tarqatiladigan ochiq foydalanish maqolasi hisoblanadi (<https://creativecommons.org/licenses/by/4.0/>).



INTERNATIONAL EXPERIENCES OF DEVELOPING THE DIGITAL ECONOMY

Abstract: This article examines the digital transformation of the world economy and the experiences of the USA, China and Germany, as well as the application of the experiences of developed countries in Uzbekistan.

Keywords: World economy, digital transformation, digital economy, GDP, digital technologies, artificial intelligence, cyber security.



Authors

Lutfiy Farangiz Sharidin kizi

Department of Digital Economy and Financial Technologies, University of Management and Future Technologies,

Tashkent, 100208, Uzbekistan;

Ismailova Mohigul Yusubjon kizi

Department of Digital Economy and Financial Technologies, University of Management and Future Technologies,

Tashkent, 100208, Uzbekistan;



Copyright: © 2024 by the authors.

This article is an open access article distributed under the terms and conditions of the Creative Commons Attribution (CC BY) license (<https://creativecommons.org/licenses/by/4.0/>).

Kirish

Raqamli iqtisodiyot – bu 21-asr iqtisodiyoti. Texnologik progress jahon iqtisodiyot modellarini o'zgartirishga ta'sir qiladi. Bu tendensiyalar ko'pgina rivojlangan davlatlar iqtisodiyati strukturasi ustida katta ta'sir ko'rsatgan. Raqamli ahamiyatlar dunyoda har xil sohalariga kirib kelmoqda. Bugungi kunda "raqamli rahbarlar" deb ataladigan eng rivojlangan raqamli iqtisodiyotga ega bo'lgan mamlakatlar Norvegiya, Shvetsiya, Shveytsariya, Daniya, Finlandiya, Singapur, Janubiy Koreya, Buyuk Britaniya, G'onkong va AQSH hisoblanadi. Bu orada, rivojlanayotgan mamlakatlar qatoriga qo'shilgan Xitoy YaIM da (36%) 7.125 trll. AQSH dollari, AQSH esa 6,3 trll. Dollar (37%) bilan raqamli iqtisodiyot ulushiga to'g'ri keladi.

Shuni aytish lozimki, hozirda, ishlab chiqarishni raqamlashtirish, robotlashtirish bo'yicha Xitoy yetakchi o'ringa chiqib oldi. Xitoy rahbari Si Szinpin 2014 yilda Xitoy fanlar akademiyasida so'zlagan nutqida, bo'lg'usi robotlar inqilobi avval Xitoyni keyin esa butun dunyoni tubdan o'zgartirishi haqida gapirib, jumladan, quyidagilarni aytgandi: "Xitoy hukumati tomonidan xitoy kompaniyalarining zimmasiga "Ulkan ma'lumotlar" (Big Data), "bulut"li hisoblash (cloud computing), "Ashyolarning interneti" (Internet of Things) texnologiyalarini tatbiq etishni tezlashtirish va "aqli fabrikalar"ni (intelligent manufacturing) tashkil etishga e'tiborni jamlash vazifasi topshiriladi". Oxirgi yillarda Xitoy kompaniyalari butun dunyoda yuqori texnologiyalar tadqiqotlariga investitsiyalar miqdorini keskin ko'paytirib, buning natijasida 2013 yildan boshlab Xitoyning sanoat robotlari bozori dunyodagi eng yirik bozorga aylandi. 2022 yilga kelib, Xitoyda har 10 000 sanoat ishchi o'rinlariga o'rtacha 150 ta robot to'g'ri kelmoqda. Bu esa, 2015 yilga qaraganda 3 barobar ko'p deganidir.

Endi, AQSh va Germaniya singari rivojlangan davlatlar bu borada Xitoydan o'zib o'tishi oson bo'lmaydi. Rasmiy ma'lumotlarga ko'ra, Germaniya sanoati internet infratuzilmasini rivojlantirishga 2025 yilga qadar yiliga 40 mlrd. investitsiya kirish Yaponiya ham bu borada ortda qolmayapti va ular o'z industriyasini rivojlantirish uchun Connected Factories (zavodlarni tarmoqqa ulash) konsepsiyasini ishlab chiqmoqdalar.

Rossiyada esa, 2017 yilda «Texnet» maxsus yo'l xaritasi qabul qilinib, uning doirasida «Raqamli iqtisodiyot 2024» dasturi tayyorlanmoqda. Qo'shni Qozog'istonda esa, ishlab chiqarishni raqamli texnologiyalarga o'tkazilishi va "Industriya 4.0" dasturi davlat strategiyasi darajasiga ko'tarildi.

Yevropa Ittifoqi raqamli iqtisodni innovatsiyalar, raqobatparvarlikni oshirish va jahon iqtisodiyoti rivojlanishida eng muhim haydovchi sifatida tushunadi. Raqamli o'zgarish yangi texnologiyalarni va innovatsion biznes modellarini hamkorlik orqali birlashtiradi. G20 ta'rifi bo'yicha raqamli iqtisodiyot ko'p tashkil etilgan iqtisodiy faoliyat turlari qatoriga kiradi va raqamli ma'lumotlar va bilimlarni ishlab chiqarishning asosiy omili sifatida, zamonaviy axborot tarmoqlari hamkorlik maydoni sifatida, texnologiyalarining foydalanishini, produktivlik o'sishi va iqtisodiy strukturani optimallashtirishning haydovchi faktori sifatida ishlatiladi. Raqamli iqtisodiyot elektron savdo va elektron biznesdan tashqari biznesni o'z ichiga qamrab oladi va transport, moliya xizmatlari, ishlab chiqarish, ta'lim, sog'liqni saqlash, qishloq xo'jaligi, savdo, media va ko'ngilochar imkoniyatlarni raqamli texnologiyalardan foydalanish orqali o'z ichiga oladi. Raqamli iqtisodiyot jamiyatning barcha sohalariga ta'sir ko'rsatadi, odamlar o'rtasidagi aloqalarni, iqtisodiy peyzajni, yaxshi ish topish uchun zarur bo'lgan ko'nikmalar va hatto siyosiy qarorlarni ham o'z ichiga oladi. Rivojlanayotgan raqamli iqtisod yangi ilmiy tadqiqot va topshirishlar, ish imkoniyatlari, iqtisodiy o'simlik va hayot sifatini oshirishi mumkin.

Xo'sh, texnologik o'zgarishlarga tayyor bo'lmagan davlatlarni ertaga nimalar kutadi? Dunyoqarashidagi, qadriyatlar tizimidagi o'ziga xosliklar tufayli, qolaversa, iqtisodiy, siyosiy va mafkuraviy sabablarga ko'ra ushbu texnologik yangiliklarni o'z vaqtida qabul qila olmagan jamiyatlar taraqqiyotda ilgari egallab turganidan ham orqada qolib ketishi tarixiy tajribadan ma'lum.



Asosiy qism

Mazkur innovatsion musobaqada O'zbekiston qanday o'rinni egallamoqda? Dunyo sanoati "Industriya 4.0" ostonasida turgan bo'lsada, lekin uning barcha texnologiyalarini faqatgina bundan oldingi "Industriya 3.0" sanoat inqilobining yutuqlarini o'zlashtira olganlariga tatbiq qila oladilar. O'zbekiston iqtisodiyotiga kelsak, tan olish kerakki biz hozir "Industriya 2.0" darajasidan "Industriya 3.0" darajasiga o'tish bosqichidamiz. Albatta, bu holat O'zbekiston sanoatini to'liq modernizatsiya qilish yo'lidagi jiddiy to'siqdir. Shubhasiz, bu muammoni tan olish va anglash – oldinga harakat qilish uchun qo'yilgan qadamdir. Prezident Shavkat Mirziyoev tomonidan 2018 yil mamlakatimizda "Faol tadbirkorlik, innovatsion g'oyalar va texnologiyalarni qo'llab-quvvatlash yili" deb e'lon qilindi. Bundan tashqari, Prezidentimiz tomonidan O'zbekistonni dunyodagi rivojlangan 20 ta davlat safiga kiritish strategik rejasi belgilab berildi. Bu ulkan va olamshumul maqsadga erishishda, O'zbekiston iqtisodiyoti va sanoatini tubdan o'zgartirib, "Industriya 4.0" tamoyillarini keng tatbiq qilinishi lozim bo'ladi.

Umuman olganda, raqamli iqtisodiyotdagi ko'p qiziqarli tomonlarning tashkil etilishi tabiiy rivojlanish natijasidir va tegishli protokollar va tamoyillarni o'z ichiga olgan, texnikaviy, tijoraviy, ijtimoiy va siyosiy savollarni hisobga olgan muvofiq prinsiplar talab qiladi.

Internet-xavfsizligi mavjudligi, o'zgarishlar tezligi va markaziy nazoratning mavjud emasligi barcha qiziqarli tomonlarning umumiy prinsiplari va protokollarini moslashtirishni talab qiladi. Masalan, Braziliyaning Internet komiteti ko'p qiziqarli tomonlarni boshqarish modellari muvaffaqiyatli ishlatadi. Innovatsion CGI.br modeli ijtimoiy tashkilotning xususiyatlari bo'lib, texnik, tijoraviy, ijtimoiy va siyosiy savollarga moslashtirilgan protokollar va prinsiplarni moslashuvchanligini ta'minlaydi.

Shuningdek, ko'p tomonlama boshqarish usullari raqamli rivojlanishning muvaffaqiyatli strategiyalarining asosiy prinsipi bo'lib, raqamli iqtisodiyotdagi barcha qiziqarli tomonlarni samarali boshqarishga imkon beradi.

Shveysariya raqamli strategiyasi dasturi ham, raqamli rivojlantirishni muvaffaqiyatli boshqarish uchun jamiyatning turli sohalarining hamkorligi muhimligini ta'kidlashni ham ko'rsatadi.

Umumiy ravishda, raqamli rivojlantirishning ko'p tomonlama xususiyatlarini boshqarishning samarali boshqarilishi, barcha qatnashchilarning qiziqishlarini hisobga oladigan prinsiplar va protokollarga ega bo'lishni talab qiladi. CGI.br modeli va Shveysariya raqamli strategiyasi dasturi kabi tadbirlash modellari, raqamli rivojlantirishni boshqarishda samarali usul yaratishni xohlavchi boshqa mamlakatlar va tashkilotlar uchun namunalar sifatida xizmat qilishi mumkin.

Braziliya internetni boshqarishning ko'plab yonalishlarini o'z ichiga olgan bir nechta tomonlama modelarni tuzgan. Bu model fuqarolik jamiyatini, hukumatni, ilmiy ahamiyatdagi shaxslarni va tijorat tashkilotlarini o'z ichiga oladi. Bu model har qanday mamlakat uchun yaxshi namuna hisoblanadi, chunki uni raqamli iqtisodiyotni boshqarishga samarali usul yaratishni xohlaydigan har qanday mamlakat uchun foydali bo'ladi.

Shveysariya raqamli strategiyasi dasturi, dialog orqali o'tkaziladigan tarmoqlashish jarayonlarini yaratishga qaratilgan. Ushbu dasturda hukumat faoliyatining asosiy prinsiplari tavsiflanadi va hukumat organlarining, ilmiy ahamiyatdagi shaxslarning, xususiy sektorning, fuqarolik jamiyatining va siyosatning birlashishi kerakligi ko'rsatiladi, barcha qatnashchilar uchun raqamli rivojlantirish jarayonini amalga oshirish uchun. Dastur, barcha federativ tuzilmalari, xususiy sektor, fuqarolik jamiyati va ilmiy ahamiyatdagi shaxslar o'rtasidagi hamkorlikni ko'rsatadi va raqamli rivojlantirish imkoniyatlaridan foydalanish uchun qo'llaniladigan asosiy vositalardan hisoblanadi.

Davlatlarda barqaror Raqamli iqtisodiyot tuzish uchun uchun maqsadga muvofiq planlashtirish va koordinatsiyaga etibor berish, shuningdek, birkator e'lonlarni bajarish kerak. Har bir hukumatning tizimida ushbu ikki modelning gibrid loyihasi amalga oshiriladi.

Ma'mul qilinganicha, kichik xukumatlar uchun markazlashtirilgan model amalga oshiriladi, katta xukumatlar uchun kengaytirilgan versiya ishlatiladi. Masalan, Singapur (Smart Nation) modelini dasturlashtirish, boshqaruvchi toshkilotni Infokommunikatsiya va rivojlantirilar agentligiga o'girdi va markaziy ijrochi agentlik'Texnologiya hukumat agentligiga transformatsiya qilindi. Estoniyada, masalan, har bir vazirlikda ma'lumotlar boshkaruvchisi bor, uning ishini ma'lumot markazi bilan koordinatsiya kiladi [8]. Boshqa tomondan, katta davlatlar elektron xukumat toshkilotlari yaratadi (masalan, Indiyaning Yagona Aniklash Tashkiloti). Ushbu raqamli hukumatlar ko'plab turli ekosistemalardan foydalanadi, ularda jamoat sektorining qatnashishi zarur. Raqamli Hukumatga ushbu yo'lni boshlash uchun:

Birinchi qadam, barcha davlat xizmatlarini internetda rivojlantirish uchun umumiy infratuzilma yaratish va kompyuterlashtirishdir.

Ikkinchi kadam, hamma davlat xizmatlarini berish uchun yagona platformaga o'tish. Asosiy urg'u foydalanuvchining mobilligi va tajribasini o'zlashtirishga qaratiladi. Estoniya va Hindiston raqamlarining identifikatsiyasi yagona tizimini yaratishga otishdilar, ko'pchilik davlat xizmatlar uchun foydalanuvchilar yagona identifikatsiyasidan foydalanishadi. Madaniyat mashtabi va Foydalonish sferalaridagi farqlarga qaramay, tizimlar muvofikligi va texnologiya maydonlaridagi integratsiyani ko'rsatadi.

Oxirgi qadam, Singapur Hukumat Texnologiyalari (Singapores GovTech) ishonchli misoli bo'lib, fuqarolarni proektlarni tahlil qilish va xizmatlarni ko'rsatishda yunalishlarni ishlatish orqali issiqlik, robototexnika va blokcheyn texnologiyalaridan foydalanib, prognozlashtirish ma'lumotlari va fuqarolar uchun manfaatdor mahsulotlarni va xizmatlarni tahlil qilishda ishlatiladi.

Bu yerda, yangi raqamli liderlar kadrlari organik rivojlantirish orqali initsiativalarni o'tkazishda faolliyat yuritadilar. Shuningdek, Singapur raqamli davlat xizmatlarini ko'rsatishda jahon lideri bo'lib, raqamli iqtisodiyotning asosiy oqimi bo'lib, mamlakat rahbariyati fuqarolarga yangiliklarni tahlil qilish va qisqacha muddatda tashkil etish maqsadida foydalanish fuqarolarni orientirlashtirish va shaxsiylashtirish hamda raqamli xizmatlarini yaratishni maqsad qiladi. Bu yerda, foydalanuvchilar ma'lumotlarini tahlil qilish va ularning raqamli harakatlarini prognozlashtirish orqali shaxsiylashtirilgan raqamli xizmatlar yaratishga qaratiladi, shuningdek, hukumat va fuqarolar orasidagi hamkorlikni kuchaytirishga qaratiladi.

Ochiq, xavfsiz va ishonchli internet ishonchli raqamli iqtisodiyotni rivojlantirishning asosiy shartlari hisoblanadi. Milliy raqamli siyosatni ishlab chiqishda hukumat xavfsizlik va maxfiylikni asosiy faktorlar sifatida ko'rib chiqishi kerak. Xavfsizlik va maxfiylik bir-biriga qarshi kelmaydi, ammo bir nechta tomondan bitta medalning ikki tomonidir.

Masalan, Avstraliya Federativ Hukumati to'liq yangi strategiya ishlab chiqarib, yangi siyosiy va fuqarolik xizmatlar yaratdi, yangi moliyaviy vositalarni ajratdi va raqamli taraqqiyotni kuchaytirish va kiber-xavfsizligini oshirish maqsadida hukumat o'zgarishlarini amalga oshirdi.

Isroil hukumati mamlakatni iqtisodiy o'sish, ijtimoiy ta'minot va milliy xavfsizlikning yurituvchi sifatida kiber-mehnatni foydalanish qobiliyatida ko'rsatgan. Isroil kiber-xavfsizlik strategiyasi birinchi navbatda kiber-mehnatni xavfsiz muhit sifatida saqlashga, kiber-tashvishlarga qarshi kurishga va ushbu sohada umumiy riskni pastga oshirishga yo'naltirilgan.

Yaponiya kiber-xavfsizlikni kompaniyalar uchun iqtisodiy investitsiya sifatida ko'rib chiqadi, va intersektorlik ikkita va uchta tomonli hamkorlikni kiber-xavfsizlikni kuchaytirish va operativ ma'lumot almashishni kengaytirish vositasiga aylantiradi.

Dunyo iqtisodiy forumining tadqiqotchilari raqamli iqtisodiyotni shakllantirish va rivojlantirish uchun zarur bo'lgan muhim umumiy sharoitlarni ajratishadi.



- Siyosiy rahbariyatning raqamli strategiyalarni amalga oshirish va initsiativalarni amalga oshirishga qarshi bo'lgan qattiq qaroratning ahamiyati;
- Raqamli iqtisodiyot uchun jadal reagirovchi bo'lish juda muhimdir. Mamlakatlar bajarilayotgan boshqaruv hujjatlari innovatsion, partnerlik va adaptiv bo'lishi kerak;
- Raqamli iqtisodiyotni shakllantirish va rivojlantirish uchun kompleks strategiya tashkil etish texnologik sohasidan tashqari turli ijtimoiy va iqtisodiy sohalarni qamrab olishi kerak;
- Raqamli o'zgarishlarni ta'minlash va raqamli infratuzilma, xizmatlar va ma'lumotlarni himoya qilish uchun to'liq boshqaruv tuzilmasi yaratish;
- Jiddiy tarmoqli aloqalariga javob beradigan ko'p tomonlama raqamli boshqaruv modeliga qarshi bo'lgan ishonch;
- Tezroq ijtimoiy-iqtisodiy ta'sirni oshirish va qonuniy muhitni yaratish uchun, xususan, kommunikatsiya infratuzilmasini yaxshilash va raqamli ijtimoiy xizmatlar yaratish uchun qo'llaniladigan muhim sheriklik.

Xulosa

Raqamli iqtisodiyotning rivojlantirilishi senariyining tuzilishi kabi ko'plab omillar, masalan, fuqarolik tuzilishi, iqtisodiy va siyosiy sharoitlar, aholining demografik tuzilishi kabi omillarga bog'liq. Raqamli iqtisodiyotni shakllantirish va rivojlantirishda turli mamlakatlar tomonidan amalga oshirilgan qabul qilingan qaroratlar, ma'lumotlar foydali misol bo'lishi mumkin. Biz regional raqamli rivojlanish dasturlarini ishlab chiqishda muvaffaq dunyo tajribasidan foydalanishni kerakli deb hisoblaymiz.

Adabiyotlar

1. O'zbekiston Respublikasi Prezidentining 2018-yil 3-iyuldagi "O'zbekiston Respublikasida raqamli iqtisodiyotni rivojlantirish chora-tadbirlari to'g'risidagi" PQ-3832-sonli qarori.
2. O'zbekiston Respublikasi Prezidentining 2020-yil 5-oktyabrdagi "“Raqamli O'zbekiston-2030” strategiyasini tasdiqlash va uni samarali amalga oshirish chora-tadbirlari to'g'risida”gi PQ-6079-sonli qarori.
3. Gulyamov S.S. va boshqalar. "Raqamli iqtisodiyot" Darslik. –T.:TDIU, 2020 y.–409 b.
4. Digital Economy report 2019, Value creation and capture: implications for developing countries. https://unctad.org/system/files/official-document/der_2019_en.pdf.
5. G20 Digital Economy Development and Initiative // http://www.g20chn.com/xwzxEnglish/sum_ann/201609/P020160912341422794014.pdf
6. World Economic Forum. Transform our lives <https://www.weforum.org/agenda/2016/11/the-digital-economy-what-is-it-and-how-will-it-transform-our-lives>

OLIY HARBIIY TA'LIM MUASSASALARIDA RAQAMLI PEDAGOGIKANING O'RNI VA AHAMIYATI

Annotatsiya: Maqolada oliy harbiy ta'lim muassasalarida ta'lim sifatini ta'minlashda raqamli pedagogikaning tutgan o'рни va ahamiyati sanab o'tilgan. Ta'limning sifat va samaradorligiga ijobiy ta'sir ko'rsatuvchi omillar tahlil qilingan. o'quv jarayonida an'anaviy va raqamli pedagogikani qo'llashidagi o'ziga xos jihatlar tahlili bayon etilgan.

Kalit so'zlar: raqamli pedagogika, oliy harbiy ta'lim muassasalari, axborot-kommunikatsiya texnologiyalar, ta'limni raqamlashtirish.



Mualliflar

Izbasarov A.F.

“Hududiy elektr tarmoqlari”
AJ boshqaruv raisining Elektr
tarmoqlaridan foydalanish bo'yicha
birinchi o'rinbosari

Abdurayimov S.S.

Chirchiq OTQMBY Boshlig'ining
o'quv va ilmiy ishlar bo'yicha
o'rinbosari

Nigmatov Z.Z.

Chirchiq OTQMBY Qo'shinlar
kundalik faoliyati va qo'shinlarni
boshqarish kafedrasida katta o'qituvchisi



Copyright: © 2024 by the authors.

Ushbu maqola Creative Commons
Attribution (CC BY) litsenziyasi
shartlari asosida tarqatiladigan ochiq
foydalanish maqolasi hisoblanadi
(<https://creativecommons.org/licenses/by/4.0/>).



Authors

Izbasarov A.F.

First Deputy Chairman of the Board of "Territory Electric Networks" JSC for the use of Electric Networks

Abdurayimov S.S.

Chirchik is the deputy head of OTQMBY for educational and scientific affairs

Nigmatov Z.Z.

Chirchik OTQMBY is a senior lecturer of the Department of Daily Activities of Troops and Troop Management

THE ROLE AND IMPORTANCE OF DIGITAL PEDAGOGY IN HIGHER MILITARY EDUCATION INSTITUTIONS

Abstract: The role and importance of digital pedagogy in ensuring the quality of education in higher military educational institutions is listed in the article. Factors that have a positive effect on the quality and efficiency of education are analyzed. the analysis of the unique aspects of the use of traditional and digital pedagogy in the educational process is described.

Keywords: digital pedagogy, higher military educational institutions, information and communication technologies, digitization of education.



Copyright: © 2024 by the authors.

This article is an open access article distributed under the terms and conditions of the Creative Commons Attribution (CC BY) license (<https://creativecommons.org/licenses/by/4.0/>).



Kirish

Yangi O'zbekistonda jamiyat xayotining siyosiy, insoniy – iqtisodiy va ma'naviy – madaniy soxalarni, shu jumladan, uzluksiz ta'lim tizimi va kadrlar tayyorlash bo'yicha tubdan islox qilish jarayonida qadam qo'ydi. Ta'lim har qanday jamiyatning ajralmas tarkibiy qismi, madaniyatning ko'rsatkichi va taraqqiyotning asosidir. Yangi O'zbekistonda amalga oshirilgan ta'limiy isloxotlar yagona maqsad – barkamol shaxs va malakaviy mutaxassisni tarbiyalash hamda tayyorlashga qaratilgan.

Barkamol shaxs va malakali mutaxassisni tarbiyalashda muxim o'rin tutuvchi ta'lim tizimiga ilg'or g'oyalarni tadbqiq etish va shu soxada uning mazmunini shakllantirish ijtimoiy zaruriyat sanaladi. Ushbu jarayon ta'lim tizimini boshqarish, uni demokratik va insonparvarlik tamoyillariga asoslanishiga ta'minlash hisobiga kechadi.

Xozirda ilg'or texnologiyalarini keng o'zlashtirilishi, harbiy faoliyatdagi ijobiy o'zgarishlar, chet el investitsiyalari ko'lamlarining kengayishi, tadbirkorlik, kichik va xususiy biznesning rivojlanishi, shuningdek, uzluksiz ta'limning fan va ishlab chiqarish bilan integratsiyalashuvi, o'quvchi – yoshlarning qobiliyatlari va imkoniyatlariga muvofiq ravishda ta'limgacha tabaqalashtirilgan yondashuvning joriy etilishi hamda ta'lim berishning ilg'or pedagogik texnologiyalari, zamonaviy o'quv – uslubiy majmualarining yaratilishi, o'quv – tarbiya jarayonining didaktik jixatdan ta'minlanishi ta'limni boshqarish tizimini takomillashtirishga asos bo'lmoqda.

Yangi O'zbekiston taraqqiyotining hozirgi bosqichida axborot-kommunikatsiya texnologiyalarining inson hayotining barcha jabhalariga, jumladan, oliy harbiy ta'lim muassasalariga ham kirib borishi kuchaymoqda. Shuningdek, bunday taraqqiyot yo'lini o'z vaqtida tanlagan davlatlar muvaffaqiyatga erishmoqda. Aksincha, eski usulda ishlayotgan davlatlar esa taraqqiyotdan ortda qolmoqda. Bu tendentsiya oliy harbiy o'quv yurtlari uchun ham xosdir.

Oliy harbiy ta'lim muassasalarida axborot-kommunikatsiya texnologiyalari (AKT) ta'limning ajralmas qismi hisoblanadi, chunki ko'plab oliy o'quv yurtlarining va oliy harbiy ta'lim muassasalarining o'quv rejasida kursanlarda zamonaviy apparat va texnik vositalardan, shuningdek, dasturiy ta'minotdan hamda kommunikatsiya texnologiyalaridan foydalangan holda professional ma'lumotlarni saqlash, taqdim etish, qayta ishlash va uni uzatish bo'yicha malaka va ko'nikmalarni shakllantirishga imkon beradigan axborot texnologiyalari bilan bog'liq fanlar mavjud. Shuningdek, AKT o'qitish vositalariga aylanib bormoqda va shuning uchun zamonaviy o'quv jarayonini elektron pochta, multimedia ilovalarini yaratish uchun mo'ljallangan dasturiy ta'minotsiz (prezentatsiyalar, video va audio materiallar va boshqalar) tasavvur qilish qiyin.

Oliy harbiy ta'lim muassasalarida - fanlar bo'yicha ta'lim resurslarini va topshiriqlarni joylashtirish, kursanlar bilimini nazorat qilish, o'qituvchi bilan fikr almashishni tashkil etishga yordam beradigan tegishli vositalarni o'zida mujassamlashtirgan ta'limni boshqarish LMS (Learning Management System) tizimlarini joriy qilinmoqda [1]. Coursera, Udacity, FutureLearn, Udey kabi platformalarga bo'lgan qiziqishning ortishi yurtimizda ham oliy harbiy ta'lim jarayonlarini boshqarish uchun mo'ljallangan "HEMIS" milliy axborot tizimining yaratishga olib kelmoqda va oliy harbiy ta'lim muassasalarining o'qituvchilari va kursanlari ushbu tizimdan foydalanish imkoniyatini yaratilmoqda [2].

AKTdan turli sohalarida keng qo'llanila borayotgani bilan bog'liq vaziyat davlatdan ushbu yo'nalishda rivojlanish strategiyasini ishlab chiqishni talab qildi.

Jahon darajasiga moslashish maqsadida O'zbekiston Respublikasi Prezidentining 2020-yil 5-iyuldagi "Raqamli O'zbekiston – 2030" strategiyasi va uni samarali amalga oshirish chora-tadbirlarini tasdiqlash to'g'risida"gi PF-6079-son qarori qabul qilindi.

Strategiya ikkita dasturni tasdiqlashni nazarda tutadi: hududlarni raqamlashtirish va sohalarni raqamlashtirish. Shunday qilib, ikkita yondashuv taqdim etiladi - hududiy va tarmoq. Bu, shubhasiz,

hujjatning eng keng qamrovli yoritilishi va samarali amalga oshirilishini ta'minlaydi.

Strategiyani muvaffaqiyatli amalga oshirishning eng muhim sharti aholining raqamli savodxonligini oshirishni ta'minlashdan iborat. Hujjatga ko'ra, oliy harbiy ta'lim o'qitish tizimining barcha bosqichlarida raqamli ta'limni joriy etish, IT-ta'limni rivojlantirish va hokazolar orqali aholi o'rtasida raqamli ko'nikmalar mavjudligini ta'minlash rejalashtirilgan. Shuningdek, mazkur farmonda axborot texnologiyalari va kommunikatsiyalari sohasida ustuvor yo'nalishlarda fundamental va amaliy tadqiqotlar olib borishga alohida e'tibor qaratilgan [4].

Oliy harbiy ta'lim muassasalarida o'quv jarayoniga faol qo'llaniladigan va joriy etilayotgan axborot texnologiyalarining hajmi ushbu texnologiyalardan ta'lim maqsadlarida samarali va oqilona foydalanish bo'yicha turli xil qarama-qarshi fikrlar va savollarning paydo bo'lishiga olib keladi.

Raqamli pedagogika aynan nima? Bu savolga javob berish orqali biz terminologik chalkashliklarga yo'l qo'ymaslik, pedagogik tadqiqotlarni uslubiy jihatdan malakali olib borish, maqsad va vazifalarni to'g'ri shakllantirish, qanday natijaga erishmoqchi ekanligimizni aniq tushunib olish imkoniyatiga ega bo'lamiz. Oliy harbiy ta'lim muassasalarida ta'limni raqamlashtirish orqali zamonaviy texnik vositalarning yagona transformatsiyasidir. Raqamli pedagogika ta'limning nazariy va amaliy muammolarini, ta'lim jarayonining asosiy tarkibiy qismlarini, shuningdek, raqamli texnologiyalardan foydalangan holda ta'lim xizmatlarini samarali taqdim etishni ta'minlaydigan shart-sharoitlarni o'rganadi [3].

Darhaqiqat, axborot texnologiyalarining faol joriy etilishi tufayli ta'lim sohasida yangi holat yuzaga keldi. Bunday vaziyatda ko'p qirrali pedagogik merosning saqlanishi kuzatiladi, ammo u amaliy pedagogik faoliyat modeli bilan bog'liq quyidagi yangi imkoniyatlar bilan to'ldiriladi [5]:

1. o'quv materiallarini oliy harbiy ta'lim muassasalarida qo'llab-quvvatlash tizimlarida yoki o'qituvchining shaxsiy veb-saytida joylashtirish;
2. Materiallarni elektron pochta va maxsus aloqa tarmog'lari orqali tarqatish;
3. Yuqorida qayd etilgan o'quv jarayonini qo'llab-quvvatlash tizimlaridan foydalangan holda testlar yaratish bo'yicha maxsus dasturiy ta'minot va kompyuter texnologiyalaridan foydalangan holda nazorat faoliyatini amalga oshirish;
4. Elektron pochta, ta'lim jarayonini qo'llab-quvvatlash tizimlari orqali o'qituvchi bilan kursanlarning fikr almashinuvini amalga oshirish;
5. Fanning o'quv rejasiga xorijiy va milliy ta'lim platformalaridan taniqli universitetlarning ommaviy ochiq onlayn kurslarini kiritish, yakuniy nazorat sifatida test sinovlaridan o'tish va sertifikat olish yoki kurs uchun qo'shimcha material sifatida ommaviy ochiq onlayn kurslardan foydalanish;
6. o'quv mashg'ulotlari va qo'shimcha maslahatlar sifatida kursanlar bilan onlayn ma'ruzalar yoki onlayn seminarlar o'tkazish uchun veb-seminarlar [6] va videokonferentsiyalardan [7] foydalanish, taniqli professor-o'qituvchilarning nutqlaridan takroriy foydalanish uchun yozib olish, kursanlar bilan masofadan turib ishlash; xorijda stajirovka o'tash yoki boshqa universitetlarda qo'sh diplom dasturlari bo'yicha o'qish;
7. Maxsus tayyorlangan (pedagogik jihatdan moslashtirilgan) hamda tarmoqdagi audio va video materiallardan foydalanish;
8. Kurs uchun taqdimot materiallarini yaratishda turli dasturlardan foydalanish;
9. Elektron kutubxonalar, ma'lumotlar bazalari, ilmiy jurnallarga o'quv maqsadlarida foydalanish maqsadida tarmoqqa kirish imkoniyati;



10. o'quv adabiyotlarining raqamli nusxalaridan, maxsus tayyorlangan elektron darsliklardan foydalanish.

Yuqoridagi barcha imkoniyatlar ta'lim jarayoniga yangi axborot-kommunikatsiya texnologiyalarini joriy etish bo'yicha optimal yondashuvlarni ishlab chiqish, ularni qo'llash bo'yicha yo'riqnomalar paydo bo'lishini taqozo etadi. Oliy harbiy ta'lim muassasalarida yangi texnologiyalardan foydalanishning kuchayishi bilan bog'liq bo'lgan hozirgi vaziyat pedagogik muammolarni hal qilishning ilmiy asoslangan nazariy modellari va standartlarini o'zgartirishni talab qiladi.

Bunday ilmiy asoslangan modellarning amaliyotda joriy etilishi amaliy pedagogik faoliyat texnologiyalari shaklida o'z ifodasini topgan. Oliy harbiy ta'lim muassasalarida o'quv jarayoniga yangi texnologiyalarni joriy etish bilan bog'liq vaziyat ko'rib chiqilayotganda, aynan raqamli pedagogika deb ataladigan model nazarda tutilgan.

Amaliy pedagogik faoliyatning yangi texnologiyalarni joriy etish bilan to'ldirilishi zamonaviy oliy harbiy ta'lim muhitiga yangicha qarashni keltirib chiqaradi. Bu borada oliy harbiy ta'lim muassasalari muayyan muammolarni hal qilishlari kerak, jumladan:

- Maxfiy fanlar doyrasida yangi yopiq aloqa kanallarini va nomaxfiy fanlar doyrasida Internetga keng polosali ulanishni joriy etgan holda axborot-kommunikatsiya infratuzilmasini, shuningdek, dasturiy-texnik vositalarni takomillashtirish va yangilash;
- Oliy harbiy ta'lim muassasalarining o'quv jarayonida axborot-kommunikatsiya texnologiyalaridan foydalanishga qaratilgan normativ-huquqiy hujjatlarni ishlab chiqish;
- Oliy harbiy ta'lim muassasalaridagi axborot texnologiyalari sohasida pedagog kadrlar malakasini oshirish;
- Kasbiy faoliyatida zamonaviy axborot-kommunikatsiya texnologiyalarini qo'llashga qodir mutaxassislarni tayyorlash;
- Axborotni qayta ishlash sohasida kursanlarning umumiy madaniy kompetensiyalarini shakllantiruvchi hamda "Raqamli O'zbekiston – 2030" strategiyasida ta'lim muassasalari oldiga qo'yilgan vazifalar hal etilishini ta'minlovchi o'quv dasturlari va fanlar mazmunini davriy yangilab boorish.

Zamonaviy ta'lim sharoitida pedagogika oldida turgan vazifalar hajmining ortib borishi pedagogik tadqiqotchilardan ham, pedagogik amaliyotchilardan ham jiddiy harakatlarni talab qiladi. Bu borada V.V. Grinshkun o'z qarashlarini aniq ifodalaydi: "Ta'limni axborotlashtirishga mutanosib va asosli yondashuvlarni izlash zarur, bunda axborotlashtirishning o'zini yakuniy maqsad deb hisoblab bo'lmaydi, balki kursanlarni o'qitish samaradorligini oshirish bilan bog'liq muammolarni hal qilishga yo'naltirilishi kerak." [8].

Xulosa

Xulosa qilib aytganda, jadal rivojlanayotgan axborot texnologiyalarini ta'lim jarayoniga joriy etish professor-o'qituvchilarga aniq ta'limiy natijani olish uchun oqilona va samarali o'qitishni ta'minlash imkonini beradigan optimal metodikani tanlash imkoniyatidir.

o'qituvchi to'g'ri tanlov qila olishi uchun esa oliy ta'lim zamonaviy ta'lim muhitida axborot texnologiyalari qamrovining oshishi bilan yuzaga kelgan o'zgarishlardan foydalanish bo'yicha ilmiy asoslangan tavsiyalar ishlab chiqish talab etiladi. Buning uchun esa pedagog tadqiqotchilar tomonidan ilmiy izlanishlar olib borish zarur.

Adabiyotlar

1. O'zbekiston Respublikasi Prezidentining 2020-yil 5-iyuldagi "Raqamli O'zbekiston – 2030" strategiyasi va uni samarali amalga oshirish chora-tadbirlarini tasdiqlash to'g'risida"gi PF-6079-son qarori.
2. Aglyamzyanova G.N., Gumerova L.Z., Digital pedagogi in higher school: using student simulation learning. Russian Journal of Education and Psychology 2021, Tom 12, № 1-2, <http://rjep.ru>
3. Бережнова Е.В. Условия организации skype конференций в профессиональной подготовке переводчиков. / Е.В. Бережнова, Д.А. Петрова // Образование и общество. – 2017. – Т. 4. – № 105. – С. 85–88.
4. Гриншкун В.В. Проблемы и пути эффективного использования технологий информатизации в образовании: Сообщение для обсуждения на заседании бюро отделения философии образования и теоретической педагогики РАО (при участии отделений профессионального образования и общего среднего образования) / В.В. Гриншкун. 27 февраля 2018 г.
5. Калинина С.Д. Вебинар как форма электронного обучения в высшей школе / С.Д. Калинина // Вестник МГИМО Университета. – 2015. – № 2 (41). – С. 291–295.
6. Калинина С.Д. Массовые открытые онлайн курсы (МООС): педагогический ресурс или маркетинговый ход? // Форум «Преподаватель в среде e_learning»: Сборник докладов и тезисов. – М.: Московский государственный университет экономики, статистики и информатики, 2014. – С. 82–86.
7. Калинина С.Д. Цифровая педагогика: революционный сдвиг педагогической парадигмы или новое видение современной образовательной среды? Образование и общество. № 5 (112). Сентябрь–октябрь. 2018.
8. Тихомирова Е. Живое обучение: Что такое e-learning и как заставить его работать // – М.: Альпина Паблишер, 2016. – 236 с.
9. Ashurov J.Dj., Zamonaviy ta'lim muhitida raqamli pedagogikaning o'rnini va ahamiyati // Eurasian journal of academic research, Innovative Academy Research Support Center / Volume 1 Issue 9, December 2021 ISSN 2181-2020



BO'LAJAK MUHANDIS- PEDAGOGLARNI LOYIHALASH KOMPETENSI- YALARINI KOMPYUTER GRAFIKASI VOSITASIDA RIVOJLANTIRISH MODELI

Annotatsiya: Maqolada bo'lajak muxandis-pedagoglarni loyihalash kompetensiyalarni kompyuter grafikasi vositasida rivojlantirish bosqichlari asosida maqsad, mazmun, jarayon va natijani o'z ichiga olgan loyihalash kompetensiyalarini rivojlantirish modeli ishlab chiqildi. Loyihalash kompetensiyalarni kompyuter grafikasi vositasida rivojlantirish tashkil etuvchi komponentlarni (motivatsion-qadriyatli, ijodiy-faoliyatli, operatsion-texnologik) aniqlash hamda "Bo'lajak muxandis-pedagoglarni loyihalash kompetensiyalarni kompyuter grafikasi vositasida rivojlantirish" modeli mazmuni yoritib berildi.

Kalit so'zlar: motivatsion-qadriyatli, ijodiy-faoliyatli, operatsion-texnologik, model, kompyuter grafikasi, loyihalash, kompetensiya, muhandis-pedagog.



Mualliflar

Kayumova Kamola

Muhammad Al-Xorazmiy nomidagi
Toshkent Axborot Texnologiyalari
Universiteti Nurafshon filiali,

Nurafshon, O'zbekiston;

Dilshod Mansurov

Kommunikatsiya va raqamli
texnologiyalar kafedrası, "University
of Management and Future
Technologies" universiteti,

Toshkent, 100208, O'zbekiston;



Copyright: © 2024 by the authors.

Ushbu maqola Creative Commons
Attribution (CC BY) litsenziyasi
shartlari asosida tarqatiladigan ochiq
foydalanish maqolasi hisoblanadi
(<https://creativecommons.org/licenses/by/4.0/>).



Authors

Kayumova Kamola

Nurafshan branch of Tashkent University of Information Technologies named after Muhammad Al-Khorazmi,

Nurafshan, Uzbekistan;

Dilshod Mansurov

Department of Communication and Digital Technologies, "University of Management and Future Technologies",

Tashkent, 100208, Uzbekistan;

MODEL OF DEVELOPMENT OF DESIGN COMPETENCIES OF FUTURE ENGINEER-EDUCATORS USING COMPUTER GRAPHICS

Abstract: In the article, based on the stages of development of design competencies of future engineer-pedagogues with the help of computer graphics, a model of development of design competencies including goal, content, process and result was developed. Identifying the components (motivational-valuable, creative-active, operational-technological) that make up the development of design competencies by means of computer graphics and the content of the model "Development of design competencies of future engineers-pedagogues by means of computer graphics" was clarified.

Keywords: motivational-valuable, creative-active, operational-technological, model, computer graphics, design, competence, engineer-pedagogue.



Copyright: © 2024 by the authors.

This article is an open access article distributed under the terms and conditions of the Creative Commons Attribution (CC BY) license (<https://creativecommons.org/licenses/by/4.0/>).



Kirish.

Kompyuter grafikasi fanini o'qitishda jahonning yetakchi oliy talim muassasalarida zamonaviy xorijiy tajribalarga asoslanib yangi pedagogik texnologiyalardan foydalanish, soha mutaxassisliklarini kasbiy-pedagogik faoliyatga tayyorlashda, grafik dasturlar orqali tushuntirish hamda ta'limning ishlab chiqarish bilan integratsiyasini bog'lash, bo'lajak muhandis-pedagoglarning loyihalash madaniyatini rivojlanishiga sabab bo'lmoqda. Rivojlangan mamlakatlarda individual mashinalar emas, balki yaratilayotgan mashinalarning normal ishlashini ta'minlaydigan texnik tizimlar yaratilmoqda. Ushbu yaratilgan tizimlar tobora murakkablashib bormoqda, bu esa o'z navbatida bo'lajak muhandislar ishidagi o'zgarishlar va muammolarni keltirib chiqarmoqda. Muhandis-pedagog ma'lum bir ishlab chiqarish sohasidagi texnologiya va texnologiyalarning o'ziga xos xususiyatlarini bilishi, amaliy kasbiy-pedagogik kompetensiyaga ega bo'lishi, shuningdek, nazariy va amaliy mashg'ulotlarni tashkil etish va o'tkazishda yangi pedagogik va axborot texnologiyalarini egallagan mutaxassisdir. Zamonaviy mutaxassis o'z sohasidagi mavjud tendensiyani bilish uchun mas'uliyatni his qilishi kerak; eng yangi axborot-kommunikasiya texnologiyalarini o'zlashtirish va o'z kasbiy faoliyatida qo'llashga intilish. Bu, ayniqsa, muhandislik va o'qituvchilar tarkibiga taalluqlidir, chunki ular o'zlarining faoliyatining o'ziga xos jihatlari bo'yicha doimiy ravishda yangi bilim, ko'nikmalarni o'zlarining mehnat faoliyati davomida doimiy ravishda egallab turishlari, turli xil sohalaridagi ma'lumotlarning katta hajmini o'zlashtirishlari, tegishli sohadagi barcha yangiliklardan xabardor bo'lishlari kerak. Chunki ularning kasbiy burchi ishlab chiqarish, iqtisodiyot va ilmiy-texnik taraqqiyotning tez o'zgaruvchan sharoitida ishlashga qodir mutaxassislarni tayyorlashdir.

Adabiyotlar sharhi

Oliy ta'lim muassasalarida muhandis-pedagoglarni loyihalash kompetensiyalarni rivojlantirish xolatini o'rganish, tahlil etish, loyihalashga bo'lgan talablar hamda mavjud muammolarni aniqlash uchun qo'yiladigan talablar o'rganildi.

Muhandis-o'qituvchining faoliyati ko'p qirrali, murakkab dinamik tizim bo'lgani uchun uning funksiyalarini belgilash zarur. Muhandislik va pedagogik faoliyat funksiyalari ostida E.Zer mazmunan bir xil bo'lgan, doimiy ravishda takrorlanadigan va amalga oshirilishi muhandis-o'qituvchilarga xos bo'lgan faoliyatlardan iborat bo'lgan guruhni tushunadi. Uning tadqiqotlarida ikkita funktsiya guruhini belgilaydi: kasbni o'qitishga va kelajakdagi mutaxassisning shaxsiyatini rivojlantirishga qaratilgan maqsadli va faqat o'qituvchi muhandislarga xos bo'lgan operasion guruhlar haqida o'z izlanishlarini olib borgan. Bundan tashqari juda ko'p tadqiqotlar "Bo'lajak muhandis-pedagoglarning loyihalash faoliyatiga tayyorlash" masalalariga bag'ishlangan. Masalan: H.A. Alekseev; "Pedagogik dizaynning umumiy asoslari", M.N. Nevzorov; "Oliy ta'lim muassasalari talabalarining kasbiy kompetensiyasini shakllantirish", V.A. Adolf; "Pedagogik dizaynni o'qitishning didaktik tomoni", E.S. Zair-Bek; "Loyihalash ko'nikmalarini shakllantirish", N.Yu. Bugakovalarning "Bo'lajak mutaxassislarni tayyorlashni ta'minlash uchun o'quv jarayonida loyihalashni amalga oshirish" kabi ilmiy izlanishlar o'z ilmiy tadqiqotlarida nazariy asoslari keltirib o'tilgan.

Tadqiqot metodologiyasi

Jamiyatning loyihalash tizimiga bo'lgan ehtiyojlaridan kelib chiqqan holda, muhandis-pedagoglarning ta'lim mazmuni (DTS) hamda ularga ko'yilgan malaka talablari o'rganildi.

Bo'lajak muhandis-pedagoglarni loyihalash kompetensiyalarini kompyuter grafikasi vositasida rivojlantirish modeli ishlab chiqildi. Mutaxassislarning tayyorlashda pedagogik jarayonlar, ta'lim jarayonini tashkil etishning didaktik asoslari, loyihalash kompetentlik komponentlari, loyihalash kompetensiyalarini kompyuter vositasida rivojlantirish bosqichlari, ta'limiy yondoshuvlar yoritib berildi.

Tahlil va natijalar muhokamasi

Zamonaviy axborot texnologiyalaridan, kompyuter grafikasidan foydalanishni o'z ichiga olgan yangi yondoshuvlar, usullar, dizayn vositalari zarur. Zamonaviy bo'lajak muhandislarga qo'yiladigan talablardan biri bu yuqori mahsuldorlikka ega kompyuterlar bilan ishlay olishi, ish muhiti hamda eng asosiysi ushbu tizimlardan foydalanish uchun qobiliyat zarurdir. Bu esa o'z navbatida loyihalash tizimiga bo'lgan ehtiyojlaridan kelib chiqqan holda o'z samarasiga egadir. Ushbu talablarni e'tiborga olgan holda muhandis-pedagoglarni loyihalash kompetensiyalarini kompyuter grafikasi vositasida rivojlantirish modeli ishlab chiqildi (rasm-1).

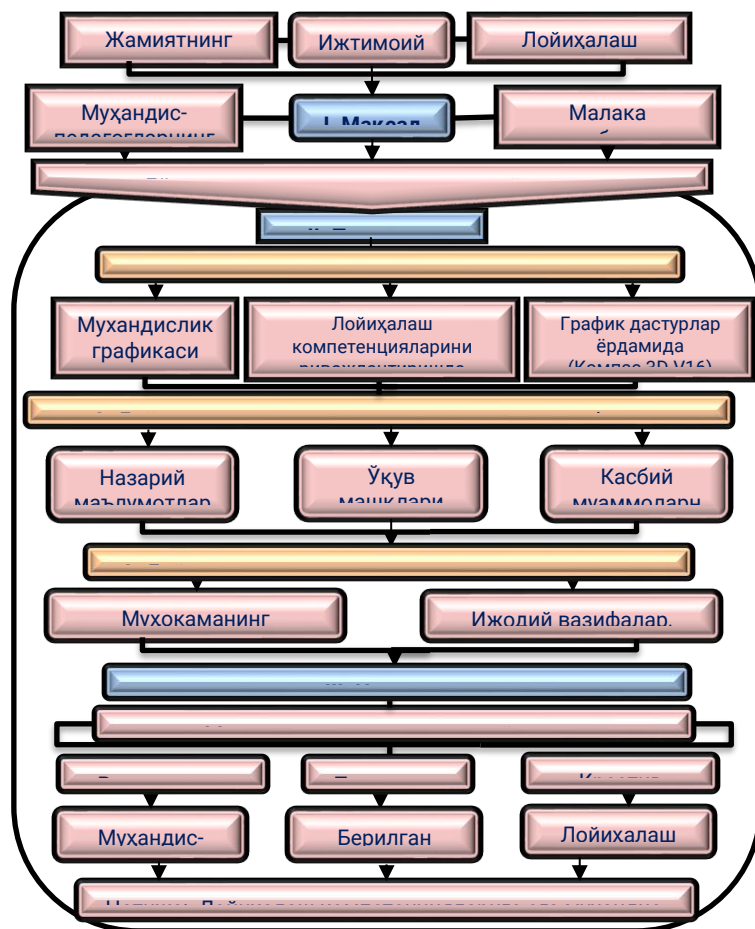

Rasm-1. Bo'lajak muhandis-pedagoglarni loyihalash kompetensiyalarini kompyuter grafikasi vositasida rivojlantirish modeli.

Loyihalash kompetensiyalarini kompyuter grafikasi vositasida rivojlantirish tashkil etuvchi komponentlarni (motivatsion-qadriyatli, ijodiy-faoliyatli, operatsion-texnologik) aniqlash. "Bo'lajak muhandis-pedagoglarni loyihalash kompetensiyalarini kompyuter grafikasi vositasida rivojlantirish" modeli mazmunini belgilash imkonini berdi. Model quyidagi bloklardan tarkib topadi: maqsadli blok, pedagogik jarayon bloki, baholash-natijaviy blok.

I.Maqsadli blok - ijtimoiy buyurtma, jamiyatning yuqori malakali mutaxassislariga va loyihalash faoliyatiga bo'lgan ehtiyojlar aniqlash hamda loyihalash kompetensiyalarini kompyuter grafikasi vositasida rivojlantirish bo'lajak mutaxassislarni bilim, ko'nikma, malaka va kompetensiyalarini rivojlantirish hamda ish beruvchi talablarini o'rganish, davlat ta'limi standartlarida belgilangan talablarni inobatga olish, shuningdek xalqaro mehnat bozori talablarini o'rganish natijasida yuzaga keladi.



II. Pedagogik jarayon blokida - bo'lajak muxandis pedagoglarni loyihalash kompetensiyalarni kompyuter grafikasi vositasida rivojlantirish mazmuni (motivatsion-qadriyatli, ijodiy-faoliyatli, operatsion-texnologik komponentlari) keltirilgan. Shuningdek loyihalash kompetensiyalarni kompyuter grafikasi vositasida rivojlantirish bosqichlari (tashkiliy tayyorgarlik, amaliy-jarayonli, analitik-korreksiyalash) berilgan. Shuningdek loyihalash kompetensiyalarni kompyuter grafikasi vositasida rivojlantirishda ta'limning shakl, metod va vositalari tavsiflangan. Talabalarni loyihalash kompetensiyalarni kompyuter grafikasi vositasida rivojlantirish jarayoni tamoyillariga ta'lim mazmuni, metodlari, tashkiliy shakllari va didaktik vositalarini aniqlaydigan dastlabki qoidalar nazarda tutiladi. Faoliyatning turli bosqichlarida hal qilinadigan vazifalarning o'ziga xos xususiyatlariga qarab didaktik tamoyillarning ahamiyati turlichadir hamda turli sharoitlarda u yoki bu tamoyilning ahamiyati namoyon bo'ladi.

III. Baholash-natijaviy blok - bo'lajak muxandis-pedagoglarni mashinasozlik sohasida loyihalash kompetensiyalarni kompyuter grafikasi vositasida rivojlantirish ko'rsatkichlari va baholash mezonlarini o'z ichiga oladi. Bo'lajak muxandis pedagoglarni loyihalash kompetensiyalarni kompyuter grafikasi vositasida rivojlanganlik mezonlariga mashinasozlik sohasida kasbiy kompetentlikni tavsiflovchi faoliyatga sub'ektiv munosabat va faoliyat natijalarini ob'ektiv tomonlarini aks ettiruvchi ko'rsatkichlar kiradi. Erishilgan natijalar asosida o'z navbatida talabalarining o'zlashtirish darajalarining guruhlarga ajratish mumkin. Bajarilgan loyihalarning bajarilish darajalariga qarab reproduktiv, produktiv va kreativ darajalarga bo'lish mumkin. Bunda dastlabki tushunchaga ega bo'ladi, topshiriqlarni mustaqil bajara boshlaydi, talaba tushunib tahlil qilib amaliyotda qo'llay boshlaydi.

Xulosa va takliflar

Birinchiidan, mutaxassislarni bilim, ko'nikma, malaka va kompetensiyalarni rivojlantirish hamda ish beruvchi talablarini o'rganish, davlat ta'limi standartlarida belgilangan talablarni inobatga olish, shuningdek xalqaro mehnat bozori talablarini o'rganish maqsadga muvofiq bo'ladi.

Ikkinchiidan, pedagogik jarayonlarni tashkil qilishda ta'lim jarayonini tashkil etishning didaktik asoslari, ta'lim mazmuni, innovatsion didaktik vositalar, loyihalash kompetensiyalarini rivojlantirishda interfaol metodlardan foydalanish o'z samarasini beradi.

Uchinchiidan, loyihalash kompetensiyalarini rivojlantirishda Kompas 3D V16 grafik dasturidan foydalanib, dars mashg'ulotlarini tashkil etishda talabalarining loyihalash madaniyatini rivojlantirish, fazoviy tasavvurni rivojlantirish asosiy asosiy grafik vosita hisoblanadi.

Adabiyotlar

1. Л.Н. Фридман, Наглядность и моделирование в обучении.- М., 2008. – 158 с. – ISBN 978-5-8121-4239-6.
2. G.Rasch Probabilistic model for some intelligence and attainment tests. Chicago. Univ. of Chicago Press. 2017, p. 199.
3. S.L. Wong, Ab Jalil., Fauzi Mohd Ayub A., Abu Bakar K., Tang S.H. Teaching a discrete information technology course in a constructivist learning environment: is it effective for Malaysian pre-service teachers, The internet and Higher Education, volume 6, Issue 2, 2003. – P. 193-204.
4. R.L.David. Visualisation and animation of computer graphics. Korea, 2014. 105 pp/
5. B. Jones. Computer graphics and programming. China. 2014-76 pp.
6. А.А.Холмурзаев, О.И.Алижонов, Ж.З.Мадаминов,& Р.Х.Каримов (2019). Эффективные средства создания обучающих программ по предмету «Начертательная геометрия». Проблемы современной науки и образования, (12-1 (145)), 79-80.
7. А.А.Холмурзаев, Ж.З.Мадаминов, Д.М.Рахмонов, & И.Р.Расулжонов, (2019). Методика развития профессиональной компетентности информационно-технических средств будущих учителей черчения. Актуальная наука, (4), 112-115.
8. S.S.Arziev,& M.M.Rustamova, (2020). The Modeling Method In The Integration Of Design And Engineering Graphics Disciplines. Theoretical & Applied Science, (6), 569-572.
9. J.Z.Madaminov, (2020). Methods of developing students' design competencies in the discipline "engineering and computer graphics". ACADEMICIA: An International Multidisciplinary Research Journal, 10(5), 66-71.
10. N.A.Muslimov, J.Z.Madaminov (2020), "Bo'lajak Chizmachilik o'qituvchilarini Axborot Texnologiyalari Vositasida Kasbiy Kompetentligini Rivojlantirish Metodikasi" Scientific-Technical Journal Of Ferpi , (24-1,(177)).

MASOFAVIY TA'LIM OLUVCHILAR FAOLIYATINI INTEGRALLASHGAN MONITORINGINI OLIB BORISH KO'RSATKICHLARI

Annotatsiya: Ushbu maqolada men shuni bildimki har qanday axborot texnologiyalarida raqamli texnologiya shuningdek ta'lim jarayonida monitoring va axborot xavsizligi yuzasidan barcha xavsizlikga ega bo'lishlari zarur. Ta'lim jarayoniga texnologiyalarni joriy etish, interfaol o'quv materiallarini yaratish, malakali kadr yaratish zaruriy chor hisoblanadi.

Kalit so'zlar: ta'lim, masofaviy, pedagogika, monitoring, axborot, xavsizlik.



Mualliflar

Odil Asqaraliyev

"Perfect University" universiteti,
Toshkent, O'zbekiston;

Dilshod Mansurov

Kommunikatsiya va raqamli
texnologiyalar kafedrasini, "University
of Management and Future
Technologies" universiteti,

Toshkent, 100208, O'zbekiston;

Kayumova Kamola

Kommunikatsiya va raqamli
texnologiyalar kafedrasini, "University
of Management and Future
Technologies" universiteti,

Toshkent, 100208, O'zbekiston;

Mas'ul: mansurovdilshodbek4@
gmail.com



Copyright: © 2024 by the authors.

Ushbu maqola Creative Commons
Attribution (CC BY) litsenziyasi
shartlari asosida tarqatiladigan ochiq
foydalanish maqolasi hisoblanadi
(<https://creativecommons.org/licenses/by/4.0/>).



Authors

Odil Asgaraliyev

Perfect University, Tashkent,
Uzbekistan;

Dilshod Mansurov

Department of Communication and
Digital Technologies, University
of Management and Future
Technologies,

Tashkent, 100208, Uzbekistan;

Kayumova Kamola

Department of Communication and
Digital Technologies, University
of Management and Future
Technologies,

Tashkent, 100208, Uzbekistan;

Correspondence:

mansurovdilshodbek4@gmail.com

GUIDELINES FOR INTEGRATED MONITORING OF DISTANCE LEARNERS

Abstract: In this article, I learned that in any information technology, digital technology, as well as monitoring and information security in the educational process, must have all security. The introduction of technologies into the educational process, the creation of interactive educational materials, and the creation of qualified staff are necessary measures.

Keywords: education, remote, pedagogy, monitoring, information, security.



Copyright: © 2024 by the authors.

This article is an open access article distributed under the terms and conditions of the Creative Commons Attribution (CC BY) license (<https://creativecommons.org/licenses/by/4.0/>).



Kirish

Dunyo tajribasi shuni ko'rsatadiki, masofaviy ta'lim jarayonlarini tashkil etishda uning uzluksizligini ta'minlash hamda zam'onaviy ta'lim texnologiyalarini va kasbiy rivojlanishning yangicha shakllarini o'zlashtirish orqali mustaqil malaka oshirishga yo'naltirilgan malaka oshirishning variativ tizimini ishlab chiqish asosiy yo'nalishlar sifatida qaraladi. Angliyada yosh yoki tajribali kadrlarning tayyorlash turli yondashuvlar asosida tashkil etiladi. AQShda oliy ta'lim tizimi masofaviy ta'lim jarayonlarini monitoringi Federal ta'lim vazirligining avtomatlashtirilgan boshqaruv tizimi orqali amalga oshiriladi. Shuningdek, ta'lim oluvchilar o'z ish vaqtining 30 foizini amaliyotga yo'naltirilgan faoliyatiga ajratadilar. Bu faoliyat talabaning o'z kompetentligini amaliyotda oshirishi hamda mehnat bozoridagi mutaxassisligi bilan bog'liq bo'lgan dolzarb jarayonlar bilan uzviy aloqada bo'lishini ta'minlaydi.

O'zbekiston Respublikasi Prezidentining «2022 - 2026 yillarga mo'ljallangan Yangi O'zbekistonning taraqqiyot strategiyasi to'g'risida»gi farmonida, jumladan "...oliy ta'lim tizimini yanada takomillashtirish, ta'lim tashkilotlari infratuzilmasini yanada rivojlantirish, sohaga informatsion - kommunikatsion texnologiyalarni joriy etish" vazifalari belgilangan[1,2].

Mamlakatimizda oliy ta'lim tizimi masofaviy ta'lim jarayonlarida tub islohotlar olib borilmoqda. Jumladan, O'zbekiston Respublikasi Prezidentining 2021 yil 12 iyundagi "Oliy ta'lim muassasalarining masofaviy ta'lim tizimini yanada takomillashtirish chora-tadbirlari to'g'risida"gi PF 4732-son Farmonining qabul qilinishi masofaviy ta'lim jarayonlarini sifat jihatdan yangi bosqichga olib chiqdi. Shuningdek, O'zbekiston Respublikasi Vazirlar Mahkamasining 2020 yil 11 fevraldagi 407-sonli qaroriga muvofiq on-layn va off-layn texnologiyalariga asoslangan masofaviy o'qitish kurslarining joriy etilishi professor-o'qituvchilarning asosiy ishdan ajralmagan holda kurslarning o'quv dasturlarini mustaqil ravishda o'zlashtirish imkoniyatini yaratdi.

Ma'lumki, masofaviy ta'lim jarayonida pedagogning kasbiy mahorati rivojlantiriladi, yangi nazariy va amaliy bilimlar beriladi. Talabalarning bilim va malakalarini rivojlantirish, ularni ta'lim-tarbiya jarayonlariga tegishli yangi me'yoriy-huquqiy hujjatlar bilan tanishtirish, mustaqil malaka oshirish mazmunini aniqlashga ko'maklashish, pedagoglarga innovatsiyalarni o'quv jarayoniga tadbir etishga yordam berish kabilar malaka oshirish kurslarining vazifalariga kiradi.

Talabalarni o'z-o'zini uzluksiz kasbiy rivojlantirishga yo'naltirish muhim hisoblanadi va bu orqali pedagog o'z kasbiy o'sishining maqsadi, shakllari, vositalari hamda individual traektoriyasini mustaqil belgilaydi. Pedagogning kasbiy kompetentligi darajasi ta'lim samaradorligini rivojlantirish, ta'lim jarayonlarini dinamik o'zgaruvchan sharoitlarga moslashishi, innovatsion faoliyat va nihoyat, o'quv jarayonini sifatini ta'minlashga jiddiy ta'sir ko'rsatuvchi omillardan biri hisoblanadi.

Bunday sharoitda monitoring bo'lajak kadrlarning kasbiy sifatlarini hamda malaka oshirish jarayonlarini rivojlantirishni tashxis qilishning asosiga aylanadi. Chunki aynan monitoring axborot olishning asosiy vositasi sifatida namoyon bo'ladi, monitoringsiz adekvat, real tashxisni tasavvur qilib bo'lmaydi. Bunday holatlar monitoringning ahamiyatini va uni amalga oshirishga ilmiy yondoshuv yo'nalishlarini belgilab beradi.

Asosiy qism

Monitoring jarayonida qayta tayyorlash va malaka oshirish muassasalari faoliyati natijalari pedagog kadrlarning malaka talablariga moslik darajasi aniqlanadi.

Bunda ta'lim jarayoni sifati, o'quv va kadrlar resurslari bilan ta'minlanganlik darajasi, boshqaruv, tinglovchilarning o'quv jarayoni, pedagog kadrlar kasbiy faoliyatining natijalari monitoring obyekti hisoblanadi.

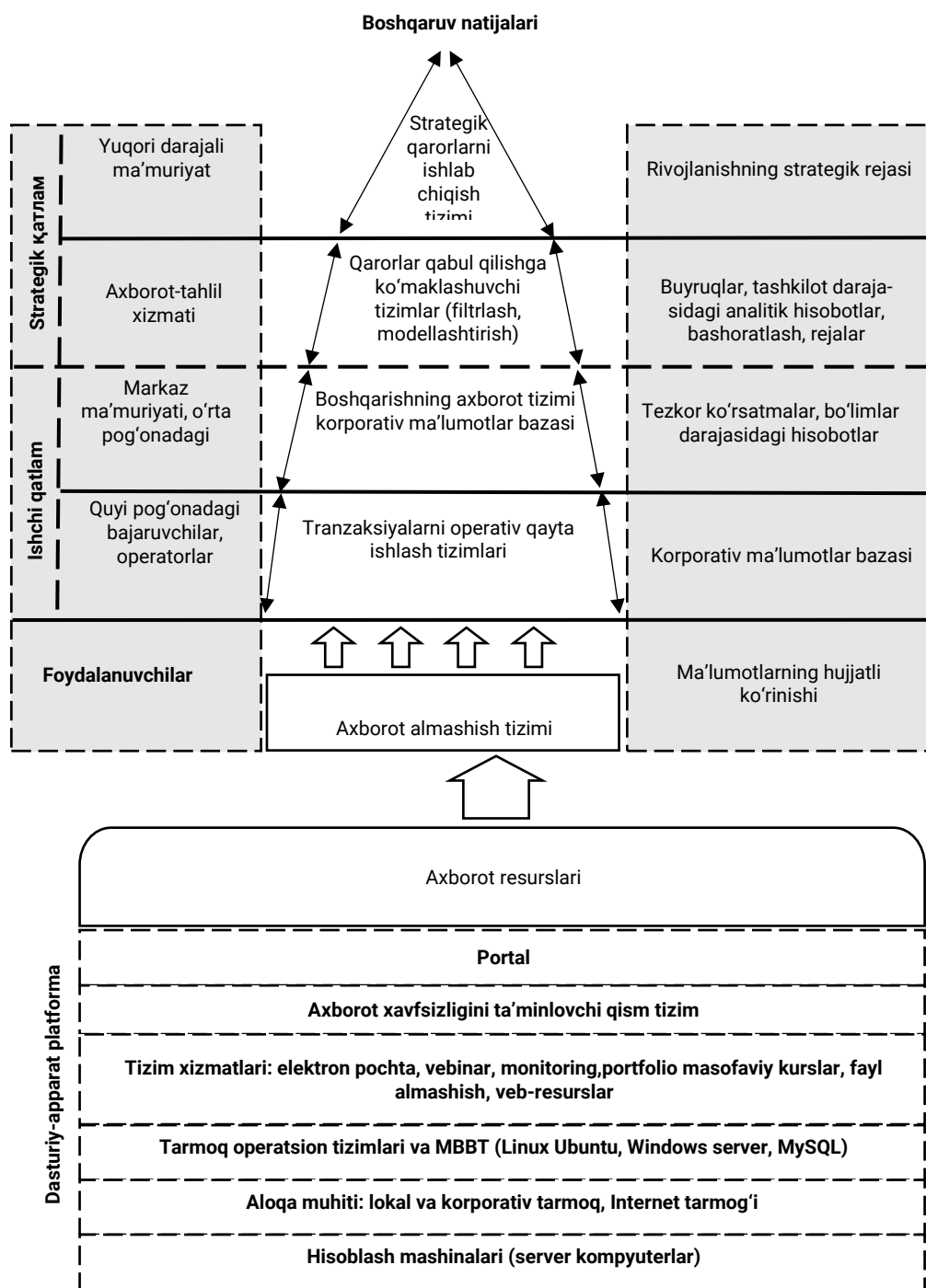

1-rasm. Axborot tarmog'i strukturasi

Odatda monitoring metodlari quyidagilardan iborat bo'ladi: kuzatish, suhbat, anketa so'rovnomasi, talabalar va pedagoglarning hujjatlari, faoliyati mahsuli va ish tajribasini tahlil qilish; natijalarni sifat jihatidan tahlil qilish va miqdoriy qayta ishlash; individual va guruhli ekspert baholash. Qayta tayyorlash va malaka oshirish ta'lim jarayoni monitoringini ta'lim ehtiyojlari va o'qitish maqsadlari, o'qitishni loyihalashtirish, rejalashtirish hamda natijalarni baholashni hisobga olgan holda olib borish zarur. Bunda qabul qilinadigan boshqaruv va pedagogik qarorlar ta'lim jarayonining barcha jihatlarini aniq tahlil qilishga asoslanishi kerak.

Tarmoq tuzilmasi ishlab chiqilgandan so'ng uning texnik va dasturiy ta'minoti masalasini hal etib olish kerak. Bizning fikrimizcha bunday tarmoq o'zining tegishli tarkibiga ega bo'lishi kerak.

Veb interfeysga ega tizimlarning ishlashi uchun Apache server, ba'lumotlar bazasini boshqarish uchun MySQL server, veb manzillarni boshqaruvchi DNS server, korporativ elektron pochta yuritish uchun Mail server, ichki fayl almashish tizimi File server, korporativ vebinar tashkil etish uchun Red5 Media server hamda Tomcat server kabi ernik litsenziyali dasturiy mahsulotlardan, shuningdek serverlar ishlashini ta'minlovchi operatsion tizimlardan foydalanilgan.

Ushbu tizimga oliy ta'lim muassasining ma'lum xodimlarigina to'g'ridan-to'g'ri murojaatlarni amalga oshirishi mumkin. Bunda ular veb interfeysdan, FTP (File Transport Protocol) bog'lanishdan, WinSCP va Putty kabi dasturlaridan foydalanadilar.

Tashqi tarmoq (Internet) dan bo'ladigan barcha murojaatlar faqat veb interfeys (vab sahifalar) orqali amalga oshiriladi.

Portalda monitoring olib borish hamda o'quv-metodik ta'minotni amalga oshirishga xizmat qiluvchi bir necha tizimlar mavjud bo'lib, ular o'zaro bir-birini to'ldirib turadi.

Xozirgi kunda axborot-kommunikatsiya tizimlariga bo'ladigan taxdidlar, ruxsatsiz tizimga kirish holatlari turli xil yo'llar bilan amalga oshirilishiga javoban xavfsizlikni ta'minlash turli xil usullar va vositalar yordamida amalga oshirilmoqda.



2-rasm. Masofaviy ta'lim markazi portalida mavjud tizimlar

Axborot xavfsizligi ta'minlashning birinchi va eng asosiy vositasi bu – foydalanuvchilarni identifikatsiyalash va autentifikatsiyadan o'tkazishdir.

Identifikatsiya – foydalanuvchining ro'yxat yozuvi (login) ni kiritishi. Foydalanuvchining tizimdagi logini orqali u haqidagi barcha kerakli axborotlarga: uning shaxsi; tizimdagi ruxsat darajasi; tizimdagi faoliyati tarixi va boshqalar ega bo'lish mumkin.

Autentifikatsiya – bu foydalanuvchining shaxsini tasdiqlashi. Odatda bu jarayon maxfiy so'z (parol) orqali amalga oshiriladi. Ya'ni foydalanuvchi dastlab tizimga o'zining kalit so'zini kiritadi va so'ng shu

kalit soʻz rostdan ham unga tegishli ekanligini maxfiy soʻz orqali tasdiqlaydi.

Identifikatsiya va autentifikatsiya vositalari birlashishi ham mumkin. Bu yerda barchamiz uchun maʼlum boʻlgan xizmat guvohnomasini keltirish mumkin. Unda shaxsning identifikatsiyasi uchun ismi, familiyasi, mansabi (va boshqa maʼlumotlar), autentifikatsiya uchun esa uning surati keltirilganligini aytishimiz mumkin. Shuni alohida taʼkidlash kerakki autentifikatsiya va identifikatsiya vositalarining oʻzi haqiqiylikni tasdiqlovchi belgilarga ega boʻlishi mumkin. Misol uchun guvohnomadagi muhr, imzo yoki uning himoyasini saqlovchi boshqa qalbakilashtirishdan himoyalovchi vositalar.

Agar foydalanuvchi bu jarayonlardan muvafaqqiyatli oʻtsa, u axborot tizimiga kirishiga va unga berilgan vakolat darajasida istalgancha foydalanish huquqiga ega boʻladi.

Hozirgi vaqtda axborot–hisoblash tizimlarida foydalanuvchilarni autentifikatsiya va identifikatsiyalashning usullarini quyidagi asosiy guruhlarga boʻlish mumkin:

- foydalanuvchidan qandaydir maxsus axborotni soʻrash (masalan, login yoki parol);
- foydalanuvchidan qandaydir maxsus tavsiyaga yoki xususiyatga ega boʻlgan ashyoni soʻrash (masalan, smart-karta, USB-token va boshqalar);
- autentifikatsiya qilinayotgan axborot foydalanuvchi tanasining muhim qismi (masalan, barmoq izlari yoki boshqa biometrik maʼlumotlar).

Demak, identifikatsiya va autentifikatsiya yordamida tizimga kirish huquqini olish mumkin. Endi foydalanish chegarasini belgilovchi mantiqiy boshqaruv vositasi ishga tushadi. Ularning vazifasi ham foydalanishga ruxsat beruvchi fizik vositalar kabidir. Foydalanishga ruxsat berishning mantiqiy boshqaruv vositalari ham foydalanuvchilarni tizimda saqlanayotgan u yoki bu axborot boʻlimiga murojaatini nazorat qiladi.

Xulosa

Axborot tarmoqlari xavfsizligini taʼminlash va ularni boshqarishni optimallashtiruvchi bir qancha dasturiy mahsulotlar mavjud. Masalan: Opsview Core; StoneGate SSL VPN; Kerio Control; OpenMediaVault va boshqalar. Korporativ tarmoqlar uchun bugungi kunda eng ommabop va qulay tizimlardan biri bu Kerio Control hisoblanib, unda quyidagi imkoniyatlar mavjud:

- internet tarmogʻiga xavfsiz murojaatni amalga oshirish;
- tezlikka chegara qoʻyish, shuningdek faqat kerakli resursga murojaatni taʼminlash orqali xarajatlarni kamaytirish;
- internetdan foydalanishni nazorat qilish orqali xodimlar ish samaradorligini oshirish;
- turli reklama, spam, va viruslardan himoyalashi va boshqalar.

Kerio kompaniyasiga 1997 yilda asos solingan boʻlib, u internet tarmogʻida maʼlumotlar bilan ishlash va almashish bilan bogʻliq keng turdagi dasturiy mahsulotlarni taqdim etadi.

Bizning fikrimizcha, oliy taʼlim muassasalari pedagog kadrlarini qayta tayyorlash va malakasini oshirish tizimining yaxlit axborot infratuzilmasini, uning dasturiy va metodik taʼminotini shakllantirish tinglovchilarning kasbiy rivojlanish dinamikasi monitoringini tashkil etishning muhim sharti hisoblanadi.



Adabiyotlar

1. «O'zbekiston Respublikasini yanada rivojlantirish bo'yicha Harakatlar strategiyasi to'g'risida»gi O'zbekiston Respublikasi Prezidentining PQ-4947-sonli Farmoni. 2017 yil 7 fevral. O'zbekiston Respublikasi qonun hujjatlari to'plami, 2017 yil, 6-son, 70-modda; 20-son, 354-modda; 23-son, 448-modda; 37-son, 982-modda.
2. O'zbekiston Respublikasining «Axborotlashtirish to'g'risida»gi qonuni. 2003 yil 11 dekabr. O'zbekiston Respublikasi Oliy Majlisining Axborotnomasi, 2004 y., 1-2-son, 10-modda; O'zbekiston Respublikasi qonun hujjatlari to'plami, 2014 y., 36-son, 452-modda.
3. Ashford-Rowe K., Malfroy J. eLearning Benchmark Report: Learning Management System (LMS) usage. 2009.
4. Bersin J., Howard C., o'Leonard K., Mallon D. Learning Management Systems. 2009.
5. Cavus N., Zabadi T. A comparison of open source Learning Management Systems. // Procedia-Social and Behavioral Sciences. 2014. № 143. r.521-526.
6. Chapman B. How Long Does it Take to Create Learning? [Research Study]. Chapman Alliance LLC, 2010.
7. Chen C.C., Chiu P.S., Huang Y.M. The learning style-based adaptive learning system architecture. // International Journal of Online Pedagogy and Course Design, 2015. 5(2), Elov B.B. Portal National University of Uzbekistan. // International Journal of Applied Engineering Research and Development. - India, 2016, - V.6. - Issue 2. - p.33-38.
8. Elov B.B., Primova M.H. LMS klasslar diagrammasi. // o'zMU xabarleri. - Toshkent, 2017, - № 2/2. 6-21 b.



Mualliflar

Asror Ulashov

Fundamental fanlar kafedrası,
“University of Management and Future
Technologies” universiteti,

Toshkent, 100208, O‘zbekiston;
ulashovasror9@gmail.com

Umida Naziraliyeva

Fundamental fanlar kafedrası,
“University of Management and Future
Technologies” universiteti,

Toshkent, 100208, O‘zbekiston;
naziraliyeva@umft.uz,

Rahmatillayeva Shahrizoda

Kommunikatsiya va raqamli
texnologiyalar kafedrası, “University of
management and future technologies”
universiteti,

Toshkent, 100208, O‘zbekiston
shaxrizodaraxmatillayeva@gmail.com

Mas‘ul: ulashovasror9@gmail.com



Copyright: © 2024 by the authors.

Ushbu maqola Creative Commons
Attribution (CC BY) litsenziyasi
shartlari asosida tarqatiladigan ochiq
foydalanish maqolasi hisoblanadi
([https://creativecommons.org/
licenses/by/4.0/](https://creativecommons.org/licenses/by/4.0/)).

FIZIKANI O‘QITISHDA “PHET – INTERACTIVE SIMULATIONS” DASTURIDAN FOYDALANISH

Annotatsiya: PhET simulyatsiyalari ta‘limda foydalanish uchun qiziqarli hamda ilmiy tadqiqotga asoslangan interaktiv simulyatsiyalar hisoblanib, ular foydalanuvchilarga faqat nazariy ma‘lumotlarni taqdim etish o‘rniga, virtual modellar bilan ishlash, parametrlarni o‘zgartirish va bu o‘zgarishlar simulyatsiya qilinayotgan tizimga qanday ta‘sir qilishini ko‘rish imkonini ham beradi. Ushbu amaliy yondashuv haqiqatan ham ko‘z bilan ko‘rib bo‘lmaydigan hamda ba‘zi murakkab tushunchalarni oson va qulay tushunishga yordam beradi. Natijada esa ta‘lim samaradorligini oshirishda katta hissa qo‘shadi.

Kalit so‘zlar: interaktiv simulatsiyalar, elektron ta‘lim, Phet.colorado.edu elektron sayti, elektr zanjir



THE USE OF “PHET - INTERACTIVE SIMULATIONS” SOFTWARE IN TEACHING PHYSICS

Abstract: PhET simulations are fun educational and research-based interactive simulations that, instead of providing only theoretical information, allow users to work with virtual models, change parameters, and see how these changes affect the system being simulated. It also allows you to see what happens. This hands-on approach really helps to understand some complex concepts that are invisible to the naked eye. As a result, it contributes greatly to the improvement of educational efficiency.

Keywords: interactive simulations, e-learning, Phet. colorado.edu website, electric circuit



Authors

Asror Ulashov

Department of Fundamental Sciences, University of Management and Future Technologies,

Tashkent, 100208, Uzbekistan;
ulashovasror9@gmail.com,

Umida Naziraliyeva

Department of Fundamental Sciences, University of Management and Future Technologies,

Tashkent, 100208, Uzbekistan;
naziraliyeva@umft.uz

Rahmatillayeva Shahrizoda

Department of Communication and Digital Technologies, “University of Management and Future Technologies”, Tashkent, 100208, Uzbekistan;

shakhrizodarahmatillayeva@gmail.com

Correspondence: ulashovasror9@gmail.com



Copyright: © 2024 by the authors.

This article is an open access article distributed under the terms and conditions of the Creative Commons Attribution (CC BY) license (<https://creativecommons.org/licenses/by/4.0/>).

Kirish

Talabalarga nazariyalarni vizual tarzda tushunishlariga yordam berish uchun PhET simulyatsiyalari grafika va intuitiv(ichki) boshqaruv vositalaridan foydalanish orqali ko'zga ko'rinmaydigan narsalarni jonlantiradi, masalan gaz molekularining bosimini, atom yardosidagi proton va neytronni yoki ular atrofida aylanayotgan elektronlarni, elektr zanjiridagi o'tkazgichdan o'tayotgan tokni ko'rsatishni misol qilib keltirsak bo'ladi:

PhET simulyatsiyalari Kolorado Boulder universitetidagi PhET Interactive Simulations loyihasi notijorat ochiq ta'lim resursi bo'lib, oson va qulay o'rganish mumkin bo'lgan simulyatsiyalarni yaratadi. PhET elektron ta'lim dasturiga 2002 yilda Nobel mukofoti laureati Karl Viman tomonidan asos solingan bo'lib u Vimanning fanni o'rgatish va o'rganish usullarini yaxshilashga qaratilgan qarashlari bilan boshlandi. Ularning vazifasi "Bepul interaktiv simulyatsiyalar orqali butun dunyo bo'ylab fan va matematik savodxonlik va ta'limni rivojlantirish" edi.

Hozirgi kunda Respublikamizda bo'layotgan yangi o'zgarishlar ta'lim sohasini tubdan yangilashini taqozo etmoqda. Darhaqiqat, teran bilimli, keng dunyoqarashli komil insonni tarbiyalash masalasi pedagoglardan yangidan yangi izlanish tamoyillarini amalga oshirishda katta ma'suliyat yuklaydi. Shu jumladan, Mamlakatimiz Prezidentining Fizika sohasidagi ta'lim sifatini oshirish va ilmiy tadqiqotlarni rivojlantirish chora-tadbirlari to'g'risidagi PQ-5032 sonli (19.03.2021) qarorida Bugungi kunda ta'lim muassasalarida fizika fanini o'qitish sifatini oshirish, ta'lim jarayoniga zamonaviy o'qitish usullarini joriy etish, iqtidorli o'quvchilarni tanlab olish, mehnat bozoriga raqobatbardosh mutaxassislarni tayyorlash, ilmiy izlanish, innovatsiyalarni rivojlantirish va amaliy samaradorlikka yo'naltirishga katta e'tibor qaratilib, yechimini topgan bir qator muammolar fizika sohasida ta'lim sifati va ilmiy izlanish samaradorligini oshirishga asoslangan tadbirlarni amalga oshirish zarurligini ko'rsatib o'tdi [1].

Hozirgi kunda aniq fanlarni sifatli darajada o'qitish pedagoglarning oldida turgan muammolardan biri hisoblanadi. Aniq fanlarni o'rganishda o'quvchilar ko'plab muammoli vaziyatlarga duch keladilar. Shuning bilan bilimlarni sifatli darajada yetkazib berishda pedagoglardan katta mahorat va o'quvchilarni darslarga qiziqtirish kerak bo'ladi. Ta'limning zamonaviy metodlaridan hisoblangan elektron ta'lim aniq fanlarni o'qitishda qo'l keladi. Elektron ta'lim — bu ta'limning elektron metodlaridan biri hisoblanadi. Odatda, kompyuter yordamida kurslarning to'liq yoki bir qismi o'qitiladi. Elektron ta'lim kurslarida Xalqaro darajadagi resurslar taqdim etiladi.

Shulardan Phet.colorado.edu elektron sayti hisoblanadi. Ushbu Phet.colorado.edu sayti fizikadan laboratoriya ishlarini oson bajarishga ko'makchi bo'ladi. Bu sayt an'anaviy uslubda o'quvchi yoki talaba nazariy materiallarni o'rganib chiqib, o'rgangan bilimini mustahkamlash uchun qulaydir[2](1745-1747 betlar). PhET saytida har xil mavzularga oid modellar mavjud bo'lib, ular Java va Macromedia flash dasturlarida yaratilgan. Loyiha qisqartmasi "PhET" dastlab "Fizika ta'limi texnologiyasi" degan ma'noni anglatardi, ammo PhET tez orada boshqa fanlarga tarqaldi. Dasturda keltirilgan modellarni nafaqat ingliz tilida, balki afrikan, arab, bengal, braziliya, portugal, xitoy, daniya, golland, fin, fransuz, nemis, yunon, gujarat, ibroniy, hind, indoneziya, italyan, yapon, koreys, marathi, norvegiya, fors, polyak, rus, ispan, turk, vietnam kabi 65 dan ortiq tildagi tarjimalari mavjud, o'zbek tilida ham 1 ta model tarjima qilingan (1-rasm).

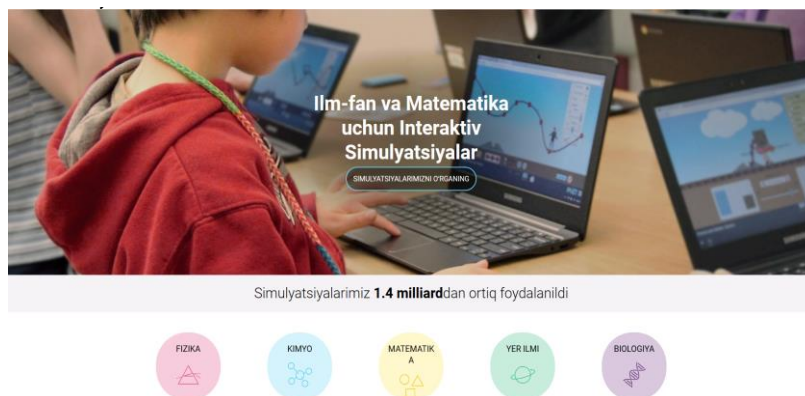

1-rasm. PhET Interactive Simulations dasturining asosiy sahifasi

Hozirgi vaqtgacha PhET veb-sayti 1.4 milliarddan ortiq tashrif buyuruvchilarni qabul qilgan.

PhET saytida taqdim etilayotgan modellar Open Source bo'lib, xohlagan foydalanuvchi bepul foydalanishi mumkin. PhET dagi modellar soni 125 dan ortiq bo'lib, ular fizika, matematika, kimyo fanlariga oid namoyish tajribalarini o'tkazish, virtual laboratoriya ishlarini tashkillashtirish va modellashtirish imkoniyatiga ega. PhET dasturi O'zbekiston davlat ta'lim standartlariga va o'quv muassasalarida qo'llanilayotgan adabiyotlariga mos keladi. PhET dasturidagi modellardan fizika, matematika, kimyo va biologiya fanlaridan dars mashg'ulotlarida namoyish tajribalari sifatida, virtual laboratoriya mashg'ulotlarini tashkillashtirishda keng foydalanish mumkin [3] (2-rasm).

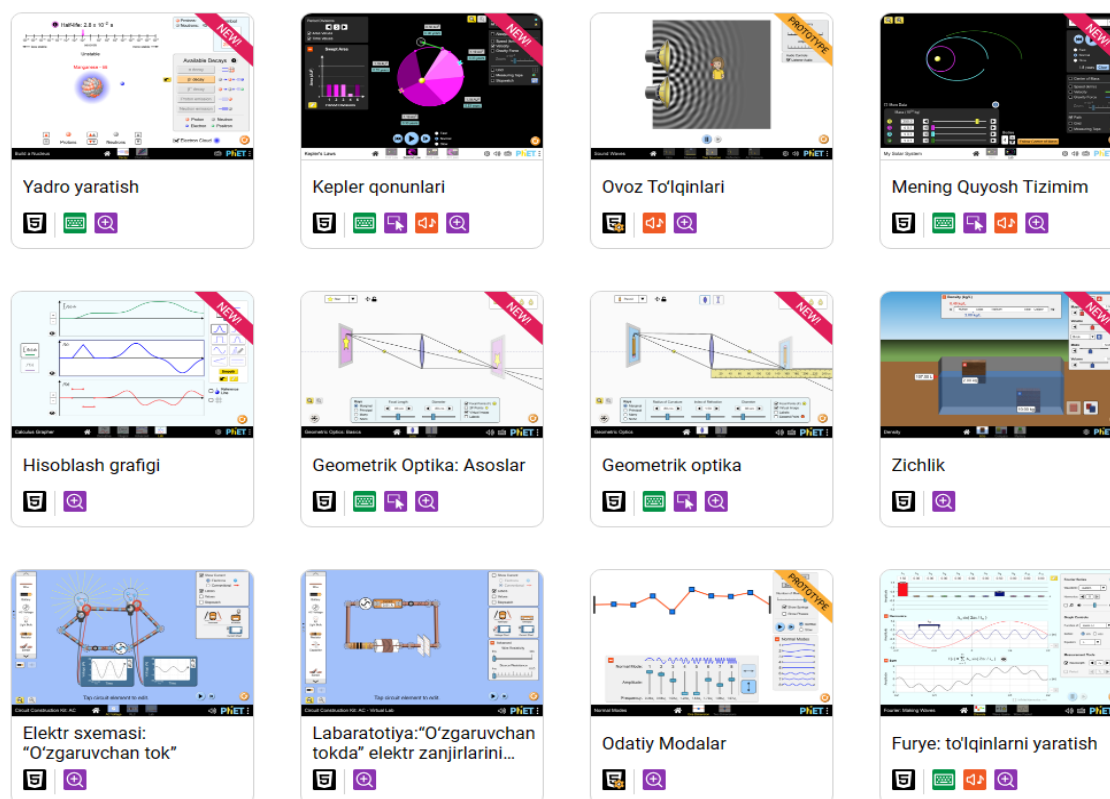

2-rasm. Fizikaga oid simulatsiyalar.

Agar dasturda keltirilgan modellarni o'zbek tiliga tarjima qilishni xohlasangiz, hech qanday qiyinchiliksiz buni amalga oshirishingiz mumkin. Buning uchun dasturning rasmiy saytida Translated Sims bandi mavjud bo'lib, u yerga kirib maxsus qaydnomani to'ldirgan holda tegishli modelni tanlab o'zbek tiliga tarjima qilishingiz mumkin.

Keling bir masala misolida ushbu simulatsiyalarning foydali tomonlarini ko'raylik.

Savol: Har birining kuchlanishi 9 V dan bo'lgan 2 ta batareya parallel ulangan va unga qarshiligi 10 Ω bo'lgan resistor, kalit, hamda lampa ketma-ket ulanib berk zanjir hosil qilingan. Kalit ulanganda lampada hosil bo'luvchi quvvatni aniqlang? (Vt)

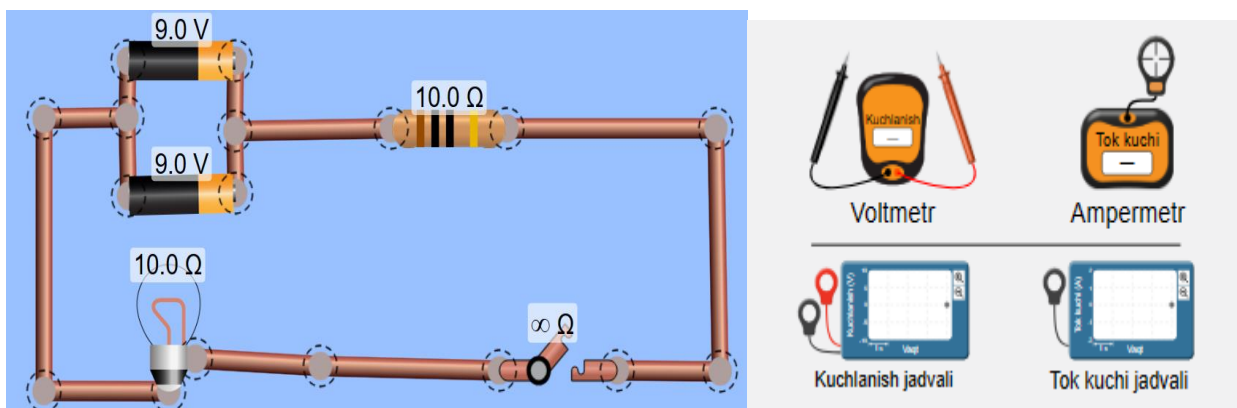

3-rasm. Elektr zanjir va o'lchov asboblari.

Yechish: Masala shartida berilganidek elektr zanjirni yig'dik va kalitni uladik. So'ngra bizga berilgan o'lchov asboblari ya'ni ampermetr yordamida lampadan o'tayotgan tok kuchi (I_L) ni va voltmetr yordamida lampadagi kuchlanish (U_L) ni aniqlab berilganlarni, formulani va yechilishini tartib bilan yozamiz:

Berilgan:

$$U_b = 9 \text{ V}$$

$$R = 10 \text{ } \Omega$$

$$I_L = 0,45 \text{ A}$$

$$U_L = 4,5 \text{ V}$$

Topish kerak?

$$P_L = ?$$

Formula:

$$P_L = I_L \cdot U_L$$

Yechish:

$$P_L = 0,45 \cdot 4,5 = 2,025 \text{ Vt}$$

Javob: lampadagi quvvat 2,025 Vt ekan.

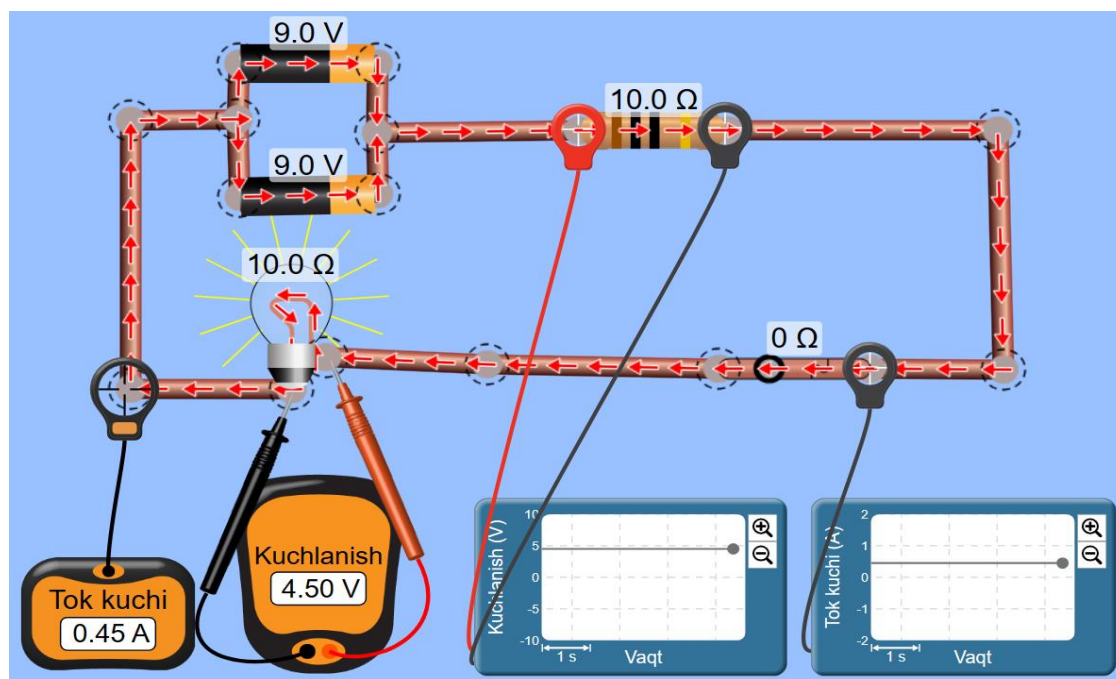

3-rasm. Elektr zanjir bo'ylab tokning o'tishi.

Xulosa

Xulosa qilib aytganda, PhET modeli orqali o'qituvchi va o'quvchiga o'rgatishni va o'rganishni oson va qulay qiladi, qolaversa fizika fanidan asosiy bilimlarni beribgina qolmay, ularda fanga qiziqishini uyg'otadi, shu tariqa bu sohada yuqori ma'lumotli kadrlar yetishtirib chiqarishga katta yordam beradi. Bu yangi pedagogik va kompyuter texnologiyalarni qo'llab o'tilgan dars an'anaviy dars o'tish usuliga qaraganda qulay va shu jumladan, o'tilgan mavzuni tez tushunishga imkoniyat yaratadi, shu bilan birga o'quvchi (talaba)larni o'z ustida ishlashga undaydi va eng asosiysi vaqtini tejashga yordam beradi. O'qituvchi o'quvchi (talaba)larga bir xil narsani takrorlab, zeriktirib qo'yishi mumkin. Shuning uchun yuqorida keltirilgan saytlar yordamida dars o'tilsa, darsning unumdorligi yanada oshgan bo'lar edi.

Adabiyotlar

1. PQ-5032 sonli Fizika sohasidagi ta'lim sifatini oshirish va ilmiy tadqiqotlarni rivojlantirish chora-tadbirlari to'g'risidagi O'zbekiston Respublikasi Prezidentining qarori. 19.03.2021.
2. O.órinova, S. Hamidova, D. Kamalova; Fizika fanini o'qitishda axborot-kommunikatsion texnologiyalarning o'rne va ahamiyati. Science and innovation international scientific journal volume 1 issue 8 uif-2022: 8.2 | issn: 2181-3337
3. Phet.colorado.edu



TERMOELEKTRIK HODISALAR AFZALLIK VA KAMCHILIKLARINI O'RGANISH

Anotatsiya: Hozirgi kunda zamon rivojlangani sayin, texnikaga bo'lgan ehtiyoj ham ortib bormoqda. Termoelektrik hodisalarning paydo bo'lishi va rivojlanishi, texnikalarning rivojlanishiga yo'l ochdi. Misol tariqasida, sayohat sumkasini olishimiz mumkin. Bu sayohat sumkasini yo'lda yoki tog'da elektr toki bilan to'ldirishning imkoniyati yo'q. Shuning uchun ham biz, bu jarayonda termoelektrik hodisalar afzallik tomonlarini ko'rishimiz mumkin.

Kalit so'zlar: Termoelektrik hodisalar, Pelt'e effekti, Zeebek effekti, Tomson effekti, elektr o'tkazuvchanlik, issiqlik o'tkazuvchanlik, termistorlar, konveksiya, nurlanish, yarimo'tkagichlar, dielektriklar, o'tkazgichlar.



Mualliflar

Umida Naziraliyeva

Fundamental fanlar kafedrası,
"University of Management and
Future Technologies" universiteti,

Toshkent, 100208, O'zbekiston;
naziraliyeva@umft.uz

Asror Ulashov

Fundamental fanlar kafedrası,
"University of Management and
Future Technologies" universiteti,

Toshkent, 100208, O'zbekiston;
ulashovasror9@gmail.com,

Mas'ul: naziraliyeva@umft.uz



Copyright: © 2024 by the authors.

Ushbu maqola Creative Commons Attribution (CC BY) litsenziyasi shartlari asosida tarqatiladigan ochiq foydalanish maqolasi hisoblanadi (<https://creativecommons.org/licenses/by/4.0/>).



Authors

Umida Naziraliyeva

Department of Fundamental Sciences, University of Management and Future Technologies,

Tashkent, 100208, Uzbekistan;
naziraliyeva@umft.uz

Asror Ulashov

Department of Fundamental Sciences, University of Management and Future Technologies,

Tashkent, 100208, Uzbekistan;
ulashovasror9@gmail.com

Correspondence: naziraliyeva@umft.uz

STUDY OF THE ADVANTAGES AND DISADVANTAGES OF THERMOELECTRIC PHENOMENA

Abstract: Nowadays, with the development of time, the need for technology is also increasing. The emergence and development of thermoelectric phenomena paved the way for the development of techniques. As an example, we can take a travel bag. There's no way to charge this travel bag on the road or in the mountains. Therefore, we can see the advantages of thermoelectric phenomena in this process.

Key words: Thermoelectric phenomena, Pelté effect, Seebeck effect, Thomson effect, electrical conductivity, thermal conductivity, thermistors, convection, radiation, semiconductors, dielectrics, conductors.



Copyright: © 2024 by the authors.

This article is an open access article distributed under the terms and conditions of the Creative Commons Attribution (CC BY) license (<https://creativecommons.org/licenses/by/4.0/>).



Kirish

Termoelektrik hodisalar hamda ularning turlari haqida umumiy ma'lumot berildi. Zeebek, Pelt'e, Tomson effektlarining afzalliklari va kamchiliklari bayon etilgan. Termoelektrik hodisalarining qo'llanilish sohalari keltirilgan. Termoelektrik hodisalar-qattiq o'tkazgichlarni ketma-ket ulash natijasida hosil qilingan, elektr toki zanjirida elektr va issiqlik jarayonlarining o'zaro bog'lanishiga asoslangan hodisalarga aytiladi. Termoelektrik hodisalar asosan uch turga bo'linadi. Ularga,

1. Zeebek hodisalar
2. Pelt'e hodisalar
3. Tomson hodisalar

ni o'z ichiga oladi.

Termoelektrik hodisalar turli xil maqsadlarda foydalaniladi. Masalan, energiya ishlab chiqishda, sovutishda, haroratni o'lchashda, isitishda va kosmik tadqiqotlarda foydalanilgan ekan. Biz esa termoelektrik hodisalardan sovutish maqsadida qanday foydalanishni o'rganamiz.

Moddalarning elektr o'tkazuvchanlik xususiyatlarini tekshirib, ularni uch xilga ajratish mumkin: Elektr tokini yaxshi o'tkazuvchi moddalar - bular o'tkazgichlar deb ataladi. o'tkazgichlarga asosan metallar kiradi.

Elektr tokini o'tkazmaydigan moddalar - bular dielektriklar deb ataladi. Rezina, plastmassa, toza suv kabilar dielektriklardir. o'tkazuvchanligi o'tkazgichlar bilan dielektriklar orasida bo'lgan moddalar ham bor. Bu moddalarni o'tkazgich deb bo'lmaydi, chunki ular elektr tokini yaxshi o'tkazmaydi. Shuning uchun bunday moddalar yarimo'tkazgichlar deb ataladi. Mendeleyev davriy jadvalining IV gruppasiga kiruvchi germaniy - Ge, kremniy Si, selen Se shuningdek, III va V gruppasidagi elementlarning kimyoviy birikmasidan hosil bo'lgan murakkab moddalar: arsenid-galliy - GaAs, fosfor-galliy - GaP va shunga o'xshash moddalar yarimo'tkazgichlardir. Odatda yarimo'tkazgichlarning xususiy elektr o'tkazuvchanligi uncha katta bo'lmaydi, chunki ularda erkin elektronlar soni juda oz, masalan uy haroratsida germaniyda erkin elektronlar konsentratsiyasi $\approx 3 \cdot 10^{13} \text{ sm}^{-3}$ atrofida bo'ladi. Tajribalarning ko'rsatishicha yarimo'tkazgichning haroratsi 1°C ko'tarilganda uning elektr qarshiligi 3-5% ga kamayadi va ularning xususiy elektr o'tkazuvchanligi ortadi. Metallarda bu holning teskarisi bo'lib, harorati 1°C ko'tarilganda qarshiligi 0,3% ga ortadi. Issiqlik ta'sirida elektr qarshiligini o'zgartiradigan elementlarga termistorlar deyiladi. Issiqlik haroratlarini o'lchashda ishlatiluvchi termo resistor hamda termistorlar thermostat sifatida hozirgi davr texnikasida amalda unumli qo'llanilmoqda.

Issiqlik temperaturalar farqi tufayli energiya uzatish jarayoniga issiqlik o'tkazuvchanlik deyiladi. Issiqlik o'tkazuvchanligi - bu materialning issiqlikni o'tkazish yoki uzatish qobiliyatidir. Bir joydan boshqa joyga bunday o'tish uchta turlicha bo'lgan jarayonlar orqali yuz beradi: o'tkazuvchanlik, konvektsiya, nurlanish.

Issiqlik o'tkazuvchanlik qobiliyati- biz buni termodinamikaning ikkinchi qonunini orqali tushuntirishimiz mumkin. Termodinamikaning ikkinchi qonuni- hech qachon temperatura sovuq jismdan issiq jisimga oqib o'tmaydi. Har doim temperatura issiq jismdan sovuq jisimga oqib o'tadi. Bundan ko'rinib turadiki, elektrni yaxshi o'tkazuvchi temir (mis, alyumini, kumush, oltin va boshqalar) issiqlikni yomon o'tkazuvchi moddalar tarkibiga esa quruq o'tinni misol keltirishimiz mumkin.

Materiallar va usullar: p-n o'tkazgichlar. Bizga bu tadqiqot uchun bir xil temperaturali ikki xil jism yoki temperaturasi har xil bo'lgan bir xil jism zarur. Termoelektrik hodisalarini o'rganishda biz bir xil temperaturali ikki xil o'tkazgich yoki temperaturasi har xil bo'lgan bir xil o'tkazgichlarni ketma-ket ulash usulidan foydalanamiz.

Masala: Termoelektrik hodisalarining afzallik va kamchiliklarini o'rganish.

Zeebek effekti- bu harorat farqi natijasida hosil bo'lgan elektr potentsiallar farqi. Ikki xil o'tkazuvchi material bir-biri bilan aloqa qilganda va har xil haroratga ega bo'lsa, ular bir o'tkazuvchan materialdan boshqasiga elektr tokini hosil qilishi mumkin. Bu ta'sir shunday deb nomlanadi. Termodinamik effekt va birinchi marta nemis olimlari tomonidan kashf etilgan. Uni 1821-yilda Iogann Zeebek kashf etgan.

Zeebek effektining o'ziga yarasha afzalliklari va kamchiliklari mavjud. Zeebek effektini qo'llanilishi: Zeebek effektining afzalliklari:

- a) temperaturalar farqi orqali energiyani hosil qilish;
- b) yuqori ishonchlilik
- c) Energiya manbalarini bevosita elektr energiyasiga aylantirish
- d) Harorat farqini yaratish orqali elektr energiyasini yaratish.

Zeebek effektining kamchiliklari:

- a) Xavfsizlik havfi
- b) Baliqlarni nobud bo'lishi
- c) Sayyohlikka ta'siri
- d) Iqtisodiy ta'siri.

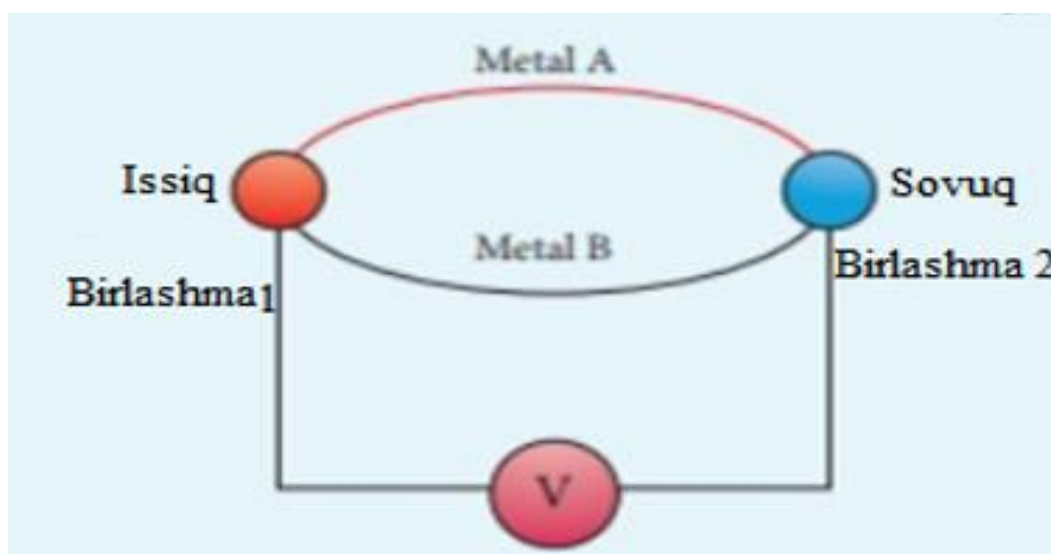

1-rasm. Zeebek effektining namoyon bo'lishi.

$$\varepsilon = \alpha(T_1 - T_2) \quad (1)$$

(1) Formula orqali biz EYuK ni Zeebek koeffitsiyenti orqali aniqlab yopishimiz mumkin hisoblanadi.

Pelt'e effekti " - bu ikki xil supero'tkazuvchi materiallar orasidagi elektr tokining o'tishi natijasida hosil bo'lgan harorat farqi ga aytiladi. Pelt'e effektining ham o'ziga yarasha afzallik va kamchiliklari mavjud.

Pelt'e effektining afzalliklari:

- a) issiqlik nasoslari sifatida foydalaniladi,
- b) ekalogik toza texnologiya hisoblanadi,

- c) aniq haroratni nazorat qilishda,
- d) tuzilishi oddiy va boshqarish jihatidan qulayligi.

Shular bir qatorda Pelt'e effektining ham kamchiliklari bor. U o'z ichiga :

- a) Kam samaradorlik
- b) Chegaraviy temperature va tezlik
- c) Narxi
- d) Quvvat cheklovi

Bir xil haroratli, ikki turdagi o'tkazgich bir-biriga ulangan joydan I tok o'tganda, u joyda ko'shimcha Q_n issiqlik miqdori ajralib chiqishi yoki yutilish hodisasi Pelt'ye effekti deb ataladi. Bu hodisada ham issiqlikning yutilishi yoki ajralib chiqishi tok yo'nalishiga bog'liq hodisasini birinchi bo'lib 1834-yili fransuz fizigi J. Pelt'ye kuzatgan. Ajralib chiqqan issiqlik miqdori

$$e) \quad Q_\pi = \pi I \tau \quad (1.4)$$

Bu yerda, π – Pelt'ye koeffitsienti

$$\pi = (\alpha_1 - \alpha_2)T \quad (1.5)$$

ifoda bilan aniqlanadi.

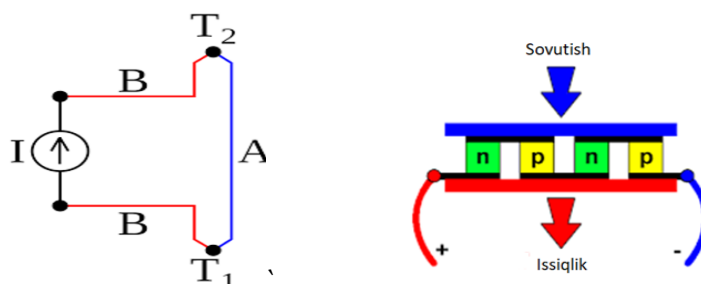

2-rasm. Pelt'e effektining namoyon bo'lishi.

Tomson effekti – Tomson yuqorida keltirilgan doimiy harorat gradientiga ega bo'lgan tokli o'tkazgichda Joule issiqligi Q dan tashqari yana qo'shimcha issiqlik miqdori ajralib chiqishi, yoki yutilishi mumkin ekanligini oldindan aytib beradi. Bu fikr keyinchalik fransuz fizigi Leru tajribalarida tasdiqladi va Tomson effekti deb nomlandi. O'tkazgichda ajralib chiqayotgan to'liq issiqlik miqdori $Q = Q_j \pm Q$ ga teng. Tomson effektini o'rganib, tahlil qilish natijasida uning afzalliklari va kamchiliklari aniqlandi.

Tomson effektining afzalliklari:

- a) Sovutish va isitish uchun ishlatilishi mumkin:
- b) Yuqori samaradorlik:
- c) Oddiy tuzilish:
- d) Ekologik toza:

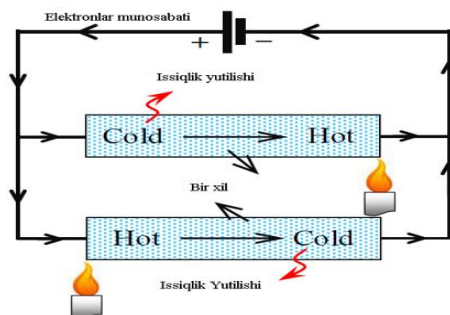

3-rasm. Tomson effektining namoyon bo'lishi.

3-rasm. Tomson effektining bir qancha kamchiliklari ham mavjud. Ularga:

- Sovutish va isitish uchun ishlatilishi mumkin:
- Yuqori samaradorlik:
- Oddiy tuzilish:
- Ekologik toza:

$$Q = K_m(T_2 - T_1)$$

Bu yerda K_m -Tomson koeffitsitenti.

Natijalar

Pelt'e effektining qo'llanilishi termoelektrik sovitish moslamalari, haroratni nazorat qilish uchun termoelektrik termostatlar, termoelektr generatorlari kabi qurilmalarni o'z ichiga oladi. Hamda, u atrof-muhit haroratining o'zgarishi nazorat qilinadigan ko'plab sanoat va ilmiy dasturlarda qo'llaniladi.

Tomson effekti faqatgina gazlar uchun foydalaniladi.

Zeebek effekti sanoat ilovalarida haroratni o'lchash, termometrlar, harorat regulyatorlari va termoelektr generatorlari kabi ko'plab sohalarda qo'llaniladi.

Xulosa

Tomson effekti harorat farqini hosil qilish uchun gazning tez kengayishi yoki siqilishi orqali ham amalga oshirilishi mumkin. Bu effekt gazni sovitish yoki isitish uchun ishlatilishi mumkin. Tomson effekti Pelt'e effektiga o'xshaydi, harorat farqini yaratish uchun ishlatilishi mumkin bo'lgan termoelektrik effekt. Tomson effekti faqat gazlar uchun, Pelt'e effekti esa suyuqlik va qattiq moddalar kabi boshqa materiallarga taalluqlidir. Tomson effekti, ayniqsa, harorat o'zgarishi bilan bog'liq bo'lgan sohalarda juda ko'p foydali sohalarni taklif qiladi.



Adabiyotlar

1. A. Azimov “Yarimo‘tkazgichlar fizikasi”. Toshkent. o‘qituvchi .
2. “Yarimo‘tkazgichli asboblarning fizikasi” o‘quv qo‘llanma O.O.Mamatkarimov, B.X.Qo‘chqorov Namangan 2019y
3. Yarimo‘tkazgichasboblarning fizikasi A.Teshaboev va boshkalar. Qo‘llanma xayot nashriyoti Andijon 2002 yil



Mualliflar

Ya.A. Axmedov

Fundamental fanlar kafedrası,
"University of Management and
Future Technologies" universiteti,

Toshkent, 100208, O'zbekiston;
yakub8788@gmail.com

X.N. Karimov

Muhammad al-Xorazmiy nomidagi
Toshkent axborot texnologiyalar
universiteti,

Toshkent, O'zbekiston;
karimovx@gmail.com

Mas'ul: yakub8788@gmail.com

FIZIKA DARSLARIDA ZAMONAVIY TEXNOLOGIYA- LARDAN FOYDALANIB TALABALAR BILIMLARINI BAHOLASH

Annotatsiya: Ushbu ishda Fizika darslarida zamonaviy platformalardan foydalangan holda talabalar tomonidan egallangan bilimlar darajasini baholash imkoniyatlari ochib berilgan. Ta'lim jarayonida innovatsion texnologiyalardan foydalanish afzalliklari tushintirib o'tilgan. Plickers, ClassMarker, Edbase FlexiQuiz, QuestBase, SpeedExam dasturlaridan foydalanishning muhim jihatlari keltirib o'tilgan. Ko'p sonli talabalarni bir vaqtning o'zida qisqa muddatda bilimni tezkor baholash va darslarda zamonaviy pedagogik texnologiyalardan foydalanish haqida so'z yuritilgan.

Kalit so'zlar: pedagogik texnologiya, Plickers, ClassMarker, Edbase FlexiQuiz, QuestBase, SpeedExam, yangi texnologiya, global tarmoq, natija, QR kod.



Copyright: © 2024 by the authors.

Ushbu maqola Creative Commons Attribution (CC BY) litsenziyasi shartlari asosida tarqatiladigan ochiq foydalanish maqolasi hisoblanadi (<https://creativecommons.org/licenses/by/4.0/>).

ASSESSMENT OF STUDENTS' KNOWLEDGE USING MODERN TECHNOLOGIES IN PHYSICS LESSONS

Abstract: This work reveals the possibilities of assessing the level of knowledge acquired by students in physics lessons using modern platforms. The advantages of using innovative technologies in the educational process are explained. Important aspects of using the programs Plickers, ClassMarker, Edbase FlexiQuiz, QuestBase, SpeedExam are noted. We are talking about the rapid assessment of the knowledge of a large number of students in a short period of time, with the simultaneous use of modern pedagogical technologies in the classroom.

Keywords: educational technologies, Plickers, ClassMarker, Edbase FlexiQuiz, QuestBase, SpeedExam, new technology, global network, result, QR code.



Authors

Ya.A. Akhmedov

Department of Fundamental Sciences, University of Management and Future Technologies,

Tashkent, 100208, Uzbekistan;
yakub8788@gmail.com

Kh.N. Karimov

Muhammad al-Khorazmi Tashkent University of Information Technologies,

Tashkent, Uzbekistan;
karimovx@gmail.com

Correspondence: yakub8788@gmail.com



Copyright: © 2024 by the authors.

This article is an open access article distributed under the terms and conditions of the Creative Commons Attribution (CC BY) license (<https://creativecommons.org/licenses/by/4.0/>).

Kirish

O'zbekiston Respublikasi Prezidentining Farmoniga [1] asosan ta'lim jarayoniga raqamli texnologiyalar va zamonaviy usullarni joriy etish bo'yicha quyidagi vazifalarni amalga oshirish lozim:

- zamonaviy axborot-kommunikatsiya texnologiyalari va ta'lim texnologiyalarining mustahkam integratsiyasini taminlash, ta'lim jarayonlarini raqamli texnologiyalar asosida individuallashtirish, masofaviy ta'lim texnologiyalarini amaliyotga keng joriy etish;
- zamonaviy axborot-kommunikatsiya texnologiyalari asosida masofaviy ta'lim dasturlarini tashkil etish;
- ta'lim yo'nalishlari va mutaxassisliklarining o'ziga xosligidan kelib chiqib, ta'lim jarayonida xalqaro miqyosda keng qo'llaniladigan zamonaviy dasturiy mahsulotlardan foydalanishni rivojlantirish.

Ushbu farmonga ko'ra, zamonaviy axborot-kommunikatsiya texnologiyalari va ta'lim texnologiyalarining mustahkam integratsiyasini taminlash, ta'lim jarayonlarini raqamli texnologiyalar asosida individuallashtirish, masofaviy ta'lim xizmatlarini rivojlantirish, zamonaviy texnologiyalarini amaliyotga keng joriy etish asosiy vazifalardan biri bo'lib xisoblanadi.

Hozirgi zamon fizika fani professor o'qituvchisining oldida talabaning fizika faniga bo'lgan qiziqishlarini yanada oshirib, dars samaradorligiga erishish, talabalarning tafakkuri, anglash erkin va mustaqil fikrlash qobiliyatlarini yanada rivojlantirish, ko'rib bo'lmaydigan jarayonlarni ko'rish, fizik jarayonlarni modellashtirish imkoniyatini hosil qilish maqsadi turibdi.

Axborot texnologiyalaridan ta'lim tizimida, ayniqsa fizika fanini o'qitishda foydalanish - darsliklarning elektron shakllari, elektron darsliklar, elektron plakatlari, test dasturlarini yaratish, masalalar yechish va xokazo bosqichlardan iborat bo'lib, yoshlarning fizika faniga bo'lgan qiziqishlarini oshirishda, xodisa va

qonuniyatlarni chuqurroq anglab yetishlarida, masofaviy va mustaqil ta'lim olishlarida muhim ahamiyatga egadir[2].

Bugungi kunda xayotimizning turli sohalarida axborot kommunikatsiya va kompyuter

texnologiyalarining kirib kelishi va jadal rivojlanish yo'liga o'tishi jamiyatimizga ijobiy ta'sir qilmoqda. Natijada insoniyat axborotlashish sohasida inkilobiy o'zgarishlar davrini boshidan kechirmokda. Dunyoda umumiy axborotlashgan hamjamiyat shakllanmoqda. Bu o'zgarishlar asosini axborotlashtirish, telekommunikatsiya va kompyuter texnologiyalari konferentsiyasi negizida axborotni uzatish va iste'molchiga yetkazib berishning eng zamonaviy va samarali vositalari dunyoga kelayotganini tashkil etadi. Oqibatda XXI asr -axborotlashgan jamiyat asri deb e'tirof etilmoqda[3].

Bugungi kunda fan va texnika va internet rivojlanishi jamiyatning axborotlashishiga olib kelmoqda. Axborot texnologiyalari hayotimizning turli jabhalariga keng va jadal kirib borishi axborotlashgan jamiyatni shakllantirishga zamin yaratmoqda. Axborotlashgan jamiyatning tashkiliy-texnologik asosini global tarmoq - internet tashkil etadi. Axborotlashgan jamiyat talablariga to'liq javob beradigan zamonoviy o'qitish texnologiyalaridan to'liq foydalangan holda dars o'tish, bugungi kundagi oliy ta'limda yetuk mutaxassislar tayyorlashda muhim o'rin egallaydi.

Axborot - kommunikatsion texnologiyalarini ta'lim jarayoniga qo'llash hozirgi vaqtdagi eng dolzarb muammolaridan biri bo'lib kelmoqda, sababi har bir sohada o'rganish, izlanish va tajriba orttirish uchun turli usullardan foydalanish kerak bo'ladi. Shuning uchun bog'chadan tortib to yuqori saviyadagi ishlarni o'rganishda hozir yangi axborot - kommunikatsion texnologiyalaridan foydalanish maqsadga muvofiqdir.



Materiallar va usullar.

Ko'p sonli va keng qamrovli talabalarni bir vaqtning o'zida katta o'quv auditoriyalarda (ma'ruza va amaliy mashg'ulotlarida) bir zumda davomat olib borish, talabalarning mavzuni o'zlashtirish darajasini tekshirishni amalga oshirish uchun ClassMarker, Edbase FlexiQuiz, QuestBase, SpeedExa, Plickers dasturlaridan foydalanish yuqori samaradorlik beradi. Ta'lim sohasida yangi bo'lgan ushbu dasturlar dunyoning ko'pgina mamlakatlarida ommaviylashib bormoqda.

Yuqorida sanab o'tilgan onlayn platformalar qulayliklari va kamchiliklarini ko'rib chiqamiz.

ClassMarker (<https://www.classmarker.com/>) [4] platformasi testlarni istalgan tilda onlayn tarzda yaratish va tarqatish imkonini beradi. 5 tadan 5 000 tagacha foydalanuvchini sinovdan o'tkazayotgan bo'lsa ham ClassMarker o'qituvchiga testlarni yaratish, tarqatish va baholash uchun ketadigan uzoq vaqtni tejashga yordam beradi. Testlarni qayta kiritish shart emas va natijalarni bir zumda va aniq hisoblanadi.

- yutuqlari - chiroyli va qulay dizayn, yopiq testlarni o'tkazish imkonini beradi.
- kamchiliklari - yuqori narx, test natijalarini yuklab olishning iloji yo'qligi.

FlexiQuiz (<https://www.flexiquiz.com/>) [5] – bu nazoratlar yoki imtihonlar yaratishda yordam beradigan yuzlab sozlanishli funksiyalarga ega onlayn test generatori. Mos ravishda jismoniy shaxslar, korxonalar va universitetlar tomonidan ishlatilishi mumkin bo'lgan moslashuvchan platforma.

- kamchiliklari - xizmatning bepul versiyasida bir qator cheklovlar mavjud. Har bir savolga rasm va video qo'sha olmaysiz va yaratilgan testni blog yoki veb-saytga joylashtira olmaysiz. Oyiga yaratilgan testlar soni cheklangan.

Edbase (<https://www.edbase.net/>) [6] - o'qituvchilar va o'qituvchilar uchun onlayn imtihon dasturiy platformasi. Edbase ning bepul talqinida oyiga atigi 10 ta foydalanuvchi va 20 ta test o'tkazishga imkon bersa-da, ular sinov paytida ekranlarni qulflash, firibgarlik xavfsizligini tekshirish va onlayn yoki oflayn funksiyalar kabi qimmatli xususiyatlar bilan ushbu cheklovlarni qoplaydi.

- kamchiliklari - Edbase ning pullik talqini oyiga 30 dollardan boshlanadi. Bunda kurslar va sinflarni yaratish hamda virtual baho jurnalida o'quvchilar baholarini kuzatish kabi ko'plab qulay funksiyalarni ochadi.

QuestBase (<https://questbase.com/>) [7]- bu Fidenia tomonidan yaratilgan onlayn baholash yechimi bo'lib, u korxonalar, davlat tashkilotlari, ilmiy muassasalar va akkreditatsiya uyushmalari tomonidan qo'llaniladi.

- qulayligi – bepul versiyasida bir qator muhim xususiyatlar taqdim qiladi; masalan, siz har oy yaratishingiz mumkin bo'lgan imtihonlar soniga cheklov yo'q. Shuningdek, siz savollarni tashqi fayllardan import qilishingiz va imtihonlarni onlayn tashkil qilishingiz yoki ularni PDF formatida eksport qilishingiz mumkin.
- kamchiliklari - bepul versiya o'z cheklovlariga ega. Ayniqsa, yirik tashkilotlar uchun Premium versiyada ishlashga majbur, chunki bepul reja 500 tagacha ro'yxatdan o'tishi mumkin bo'lgan talabalar sonini cheklaydi[8].

Quyida esa **Plickers** (<https://get.plickers.com/>) [9] dasturini qulayliklarini ko'rib chiqamiz. Plickers dasturini ishlatishda faqat professor Oo'qituvchida mobil telefon (smartfon yoki planshet) bo'lishi talab qilinadi, talabalardan xech qanaqangi mobil telefonlar yoki maxsus qurilmalar talab etilmaydi. Plickers dasturi yordamida bir vaqtning o'zida, qisqa soniyalarda butun boshli auditoriyani so'rovdan o'tkazish imkoniyatini beradi. Shu jumladan ularni o'zlashtirishini baholash hamda statistikasini chiqarish imkonini beradi. Ushbu resurs QR – kodlarni qo'llash yo'li orqali ishlaydi. Buning uchun o'qituvchiga

internetga ulangan kompyuter va smartfon, proyektor va maxsus javob variantlarini o'zida jamlagan QR kodli plickers kartalari kerak bo'ladi. Ushbu resurs bilan ishlash uchun plickers.com saytga kirish kerak va ro'yhatdan o'tish kerak bo'ladi. Shundan so'ng auditoriya talabalar uchun gruppachamiz va talabalarini ism familiyasini kiritib chiqishimiz kerak bo'ladi. Dars jarayonida oldindan tayyorlangan QR kodlarni talabalarga tarqatiladi. Talabalar o'z javob kartochkalaridan 4 ta turli xil javoblarni ko'rsatishi mumkin.

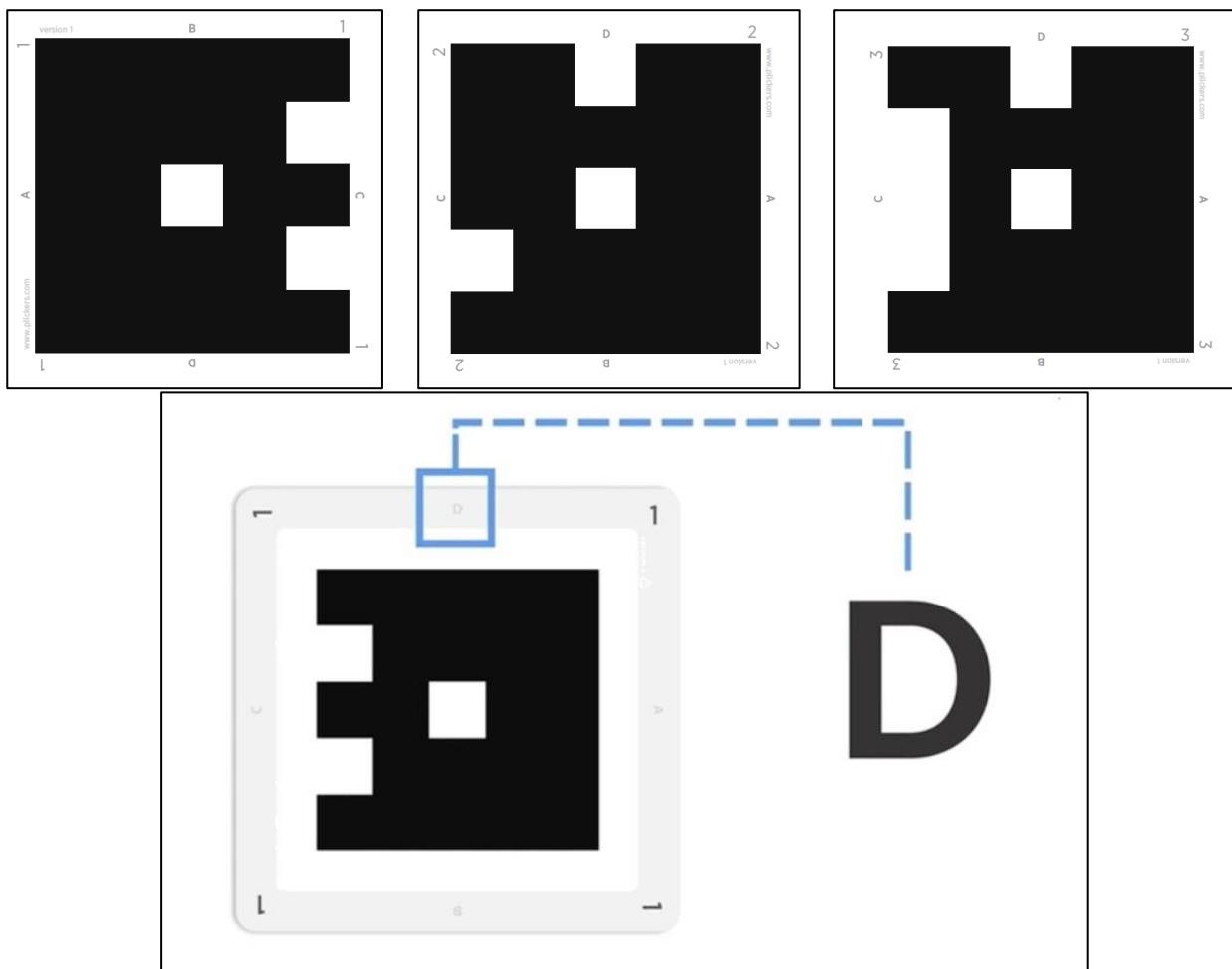

1-rasm. QR kodli kartalar.

Ilovada talabalar uchun shakllantirilgan gruppalardan talabalarning savollarga qanday javob berganini bilib olishimiz mumkin bo'ladi. Plickers javoblar diagrammasini tuzib chiqadi va talabalarning qancha qismi o'rganilayotgan materialni tushunganligini, qancha qismi qo'shimcha yordam kerakligini tezda bilish imkoniyatini beradi. Har bir kartaning burchagida siz kartaning raqamini ko'rishingiz mumkin. Har bir kartaning orqasiga talabalarning ismini yozib qo'yishingiz talabalar orasida kartaning almashib ketishi muammosini hal qilishga imkon beradi. Bu darsga tayyorlanish vaqtini tejaydi. Va nihoyat testlarni tuzishga kirishamiz. Asosiy menyudan kutubxona havolasiga kiramiz. Paydo bo'lgan ro'yhatdan yangi papka havolasini tanlaymiz. Oynada papkaning nomini yozamiz (bu fanning nomi bo'lishi ham mumkin). Keyingi qadamda yaratilgan papkaga testlarni sistemalashtiradigan kursning bo'limini yaratish mumkin. Siz bo'sh papkani ochganingizda, sizga yangi savolni tuzishingizni taklif etadi.

Plickers dasturi bilan ishlaganda quyidagi jihatlariga e'tibor qaratish kerak:

- kamera qat'iy vertikal holatda bo'lishi kerak;
- kartalar bilan ishlaganda talabalarga to'g'ri javobni ko'rsatish uchun to'g'ri variantni yuqoriga ko'rsatish kerakligini tushuntirish kerak;
- talabalar kartochkalarini QR kodni berkitmagan holda ushlab qolish kerak.

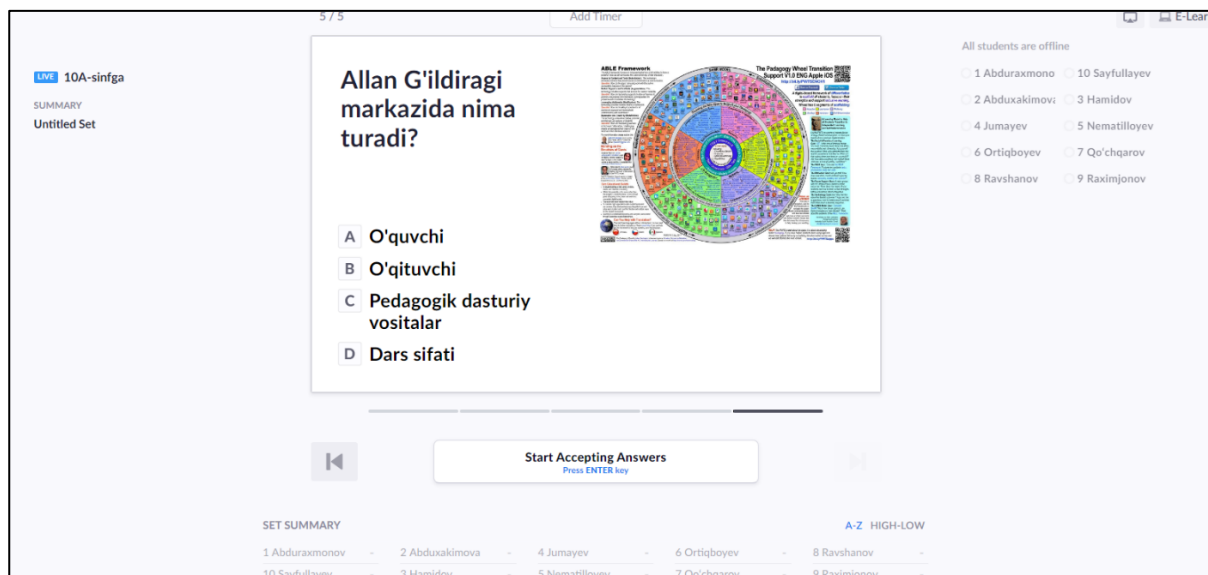

2 rasm. Plickers testning umumiy ko'rinishi.

Aksariyat hollarda bu usuldagi nazorat testlari uchun bunday tizimni qo'llash yaxshi natija bermasligi mumkin, sababi talabalar bir-birlarining javoblariga qarashga harakat qiladilar. Biroq bu auditoriyadan juda tez javob olish uchun juda yaxshi vositadir [10]. Ilovdan foydalanish orqali auditoriyadagi talabalarning berilgan savolga juda tez javoblarini olish mumkin.

Xulosa

Zamonaviy ta'lim texnologiyalaridan foydalangan holda, fizika bo'yicha o'quv eksperimenti (ko'rgazmali va laboratoriya) sifat jihatidan yangi bosqichga ko'tariladi, chunki u tajribalarni o'tkazishda ham, olingan eksperimental natijalarni ko'rish mumkin bo'lgan qayta ishlashda ham vaqtni tejaydi. Fizika darslarida talabalarning o'quv yutuqlarini tekshirish va baholash uchun zamonaviy ta'lim texnologiyalaridan foydalanish kompyuter testlarini ishlab chiqish va amalga oshirish bilan bog'liq. Kompyuter testlari talabalarning o'quv yutuqlarini individual tekshirish va baholash, u bilan bog'liq faoliyatni avtomatlashtirish (javoblarni ro'yxatga olish, ularni qayta ishlash va baholash), sub'ektiv omilni minimallashtirish va nazoratning obektivligi va samaradorligini oshirish imkonini beradi. Zamonaviy ta'lim texnologiyalari o'quvchilarning darsdan tashqari faoliyatida ham qo'llanilishi mumkin, chunki u turli xil usul va vositalardan foydalanish imkoniyatini beradigan ta'lim shaklidir. Talabalar fizika fanidan darsdan tashqari mashg'ulotlarda barcha sanab o'tilgan zamonaviy axborot-kommunikatsiya texnologiyalaridan, ayniqsa, kompyuter ta'lim texnologiyasi sifatida Internet imkoniyatlaridan foydalanishlari mumkin.

Fizika o'qitishda zamonaviy ta'lim texnologiyalaridan foydalanish ta'limning metod va vositalarini rang-baranglashtiradi va boyitadi. Talabalarning fizika bo'yicha tashkil etilgan. o'quv faoliyati qanchalik xilma-xil bo'lsa, bilimlarni egallash, ko'nikma va munosabatlarni shakllantirish shunchalik samarali

bo'ladi. Ushbu faoliyat fizika va uning qo'llanilishini o'rganishga bo'lgan bilim qiziqishini yaratishga, yangi kognitiv natijalarga erishishga yoki allaqachon olingan kompetentsiyalarni yaxshilashga olib keladi.

Zamonaviy ta'lim texnologiyalari fizika o'qitishni tashkil etish, undagi ma'lumotlar almashinuvi va samaradorligini oshirishning yangi imkoniyatlarini ochib beradi. Ko'pgina o'qituvchilar ta'lim jarayoniga yangi texnologiyani qo'llashga qarshi chiqmasada ulardan keng foydalanishni unchalik ham xush ko'rmaydilar. Chunki yangi texnologiyalar uchun juda ko'p texnik vositalar, zamonoviy bilimlar talab qiladi deb hisoblaydi. "Plickers" nafaqat ochiq kodli dastur shu bilan birga plickers o'qituvchi va talabalardan ortiqcha jihozlar talab qilmaydi. Bu esa "plickers" dan foydalanishning afzalliklarini yanada oshiradi. Plickers esa ta'limning sifat va samaradorligini oshirishga xizmat qiladi. Ta'lim jarayoniga zamonoviy texnologiyalarni qo'llash orqali ta'limning sifat va samaradorligini oshirishimiz mumkin. Shunday ekan ta'lim jarayoniga zamonoviy texnologiyalarni qo'llash orqali ta'limning sifat va samaradorligini oshirishimiz mumkin. Fundamental fizik nazariyalarga asosan fizika kursi materiallari to'g'ri va yagona sistemaga keltirilgan. Bu esa fan olamidagi barcha ilmiy yo'nalishlarning g'oyalari asosidagi ilmiy bilimlar o'quvchilarning ilmiy dunyoqarashini shakllantirish uchun asos bo'ladi, degan xulosaga olib keladi.



Adabiyotlar

1. O'zbekiston Respublikasi Prezidentining 2019 yil 8 avgustdagi "O'zbekiston Respublikasi Oliy ta'lim tizimini 2030 yilgacha rivojlantirish konsepsiyasini tasdiqlash to'g'risida"gi PF-5847-son Farmoni.
2. Maxmudov Yusuf G'aniyevich, Berkinov Alisher Abdurashidovich. Fizika fanini o'qitishda axborot kommunikasi ya texnologiyalarining o'rne. Journal of Physics and Technology Education. № 5, 2022 y.
3. Raxmatullayev R. Axborotlashgan jamiyatda internet tizimi va axborot madaniyati. Research focus, volume 1, issue 4, 2022 y. <https://doi.org/10.5281/zenodo.7528890>
4. <https://www.classmarker.com/>
5. <https://www.flexiquiz.com/>
6. <https://www.edbase.net/>
7. <https://questbase.com/>
8. <https://platforms.su/articles/4517>
9. <https://get.plickers.com/>
10. Останний Д.О., Михайлов Е.И. Технология интерактивного тестирования Plickers. Юный ученый.



Muallif

Quvonchbek Asadov

Fundamental fanlar kafedrası,
“University of Management and
Future Technologies” universiteti,

Toshkent, 100208, O‘zbekiston;
quvonchbekurinovichsadov@gmail.
com

*Mas‘ul: quvonchbekurinovichsadov@
gmail.com*

HISOB (MATEMATIKA) FANINI O‘RGANISH- DA ONLINE TIZIMLARNING IMKONIYATLARI

Annotatsiya: Ushbu maqola da biz “Hisob (matematika, calculus)” fanini o‘rganishda mathway.com onlayn tizimi imkoniyatlarini o‘rganib chiqdik. Xususan, “Funksiyani tekshirish” mavzusi misolida mathway.com onlayn tizimi yordamida hisoblashlarni amalga oshirish, natijalarni olish va tahlil qilish imkoniyatlarini ko‘rib chiqdik. Shuningdek, biz ma‘lum bir misolning yechimining natijalarini oldik va uni grafiklarini ko‘rsatdik. Shunday qilib, biz bu ishda “Hisob (matematika)” fanini o‘rganishda mathway.com onlayn tizimi imkoniyatlarini keng ekanligini ko‘rsatdik.

Kalit so‘zlar: matematika, hisob, kalkuls, mathway.com, funksiyani tekshirish, funksiyaning grafigi.



Copyright: © 2024 by the authors.

Ushbu maqola Creative Commons Attribution (CC BY) litsenziyasi shartlari asosida tarqatiladigan ochiq foydalanish maqolasi hisoblanadi (<https://creativecommons.org/licenses/by/4.0/>).



OPPORTUNITIES OF ONLINE SYSTEMS IN LEARNING ACCOUNT (MATHEMATICS).

Abstract: In this article, we studied the capabilities of the mathway.com online system in learning the science of “Calculations”. In particular, in the example of the topic “Checking the function”, we considered the possibilities of performing calculations, obtaining results and analyzing them using the mathway.com online system. We also obtained the results of the solution of a particular example and displayed its graphs. Thus, in this work, we have shown that the mathway.com online system has a wide range of possibilities in the study of “Calculation (mathematics)”.

Keywords: math, calculus, calculus, mathway.com, function check, function graph.



Author

Kuvonchbek Asadov

Department of Fundamental
Sciences, University of Management
and Future Technologies,

Tashkent, 100208, Uzbekistan;
khajudbekurinovichsadov@gmail.
com

Correspondence:

khajutbekurinovichsadov@gmail.
com



Copyright: © 2024 by the authors.

This article is an open access article distributed under the terms and conditions of the Creative Commons Attribution (CC BY) license (<https://creativecommons.org/licenses/by/4.0/>).

Kirish

Ushbu “Hisob (matematika)” kursi talabaning matematik bilimlari asosi hisoblanadi. Ta’lim yo’nalishlarini hisobga olgan holda talabalarning amaliy ko’nikmalarini oshirishga, shuningdek, dasturiy ta’minotlardan foydalanib amaliy masalalarni kompyuterda ishlashga alohida e’tibor beriladi. Shu sababdan, kursni yaxshi o’rganishdan maqsad – bo’lg’usi mutaxassislarda telekommunikatsiya, komp’yuter injiniringi, dasturiy injiniringi, komp’yuterlarga servis xizmati ko’rsatish, iqtisod va axborot xavfsizligi sohalari uchun bilim va ko’nikmalar hosil qilish uning natijasida soha mutaxassislarining kasbiy sifatini oshirish hamda ularning funksional majburiyatlarini bajarishlarini ta’minlashdan iborat. “Matematika (Hisob)” fani apparatlari yordamida zamonaviy kompyuterlar yaratish va ularga texnik xizmat ko’rsatish, ma’lumotlarni to’plash va tahlil qilish, avtomatlashtirilgan tizimli boshqarishni joriy etish va loyihalashdan iborat [1-3].

Ushbu fan umumkasbiy fanlar jumlasiga mansub bo’lib, umumkasbiy va maxsus fanlarni o’rganish uchun zarur bo’lgan bilimlar majmuidan iboratdir. Bu fandan olingan bilimlar yordamida “Algoritmizatsiya asoslari va dasturlash”, “Ma’lumotlar bazasi”, kriptografiya bilan bog’liq bo’lgan bir qancha fanlar, “EHM arxitekturasi” va boshqa bir qancha fanlarni o’rganishda muhim rol o’ynaydi [4-6].

Materiallar va usullar (MATHWAY.COM onlayn tizimi va uning funksiyani tekshirish mavzusini o’rganishdagi imkoniyatlari)

“Mathway” talabalarga matematik muammolarni tushunish va hal qilish uchun zarur bo’lgan vositalarni taqdim etadi. Millionlab foydalanuvchilar va milliardlab matematik muammolarni hal qilishga yordam bergan “Mathway” o’quvchilar, ota-onalar va o’qituvchilar uchun mavjud bo’lgan muammolarni hal qilishning eng yaxshi resursidir [7-8]. mathway.com web dasturi matematik masalarni yechish, tekshirish, grafigini chizish kabi vazifalarni qulay bajarishda yordam beruvchi qulay vosita hisoblanadi. U bizga quyidagilarni bajarish imkoniyatlarni beradi:

- *Masalalarni yechish:* “Mathway” foydalanuvchilarga matematika masala va misollarni, jumladan, algebraik tenglamalar, hisob masalalari, statistika masalalari va boshqalarni yechish imkonini beradi;

- *Bosqichma-bosqich yechimlar:* platforma kiritilgan masalalarni bosqichma-bosqich yechimlarini ishlab chiqaradi va foydalanuvchilarga har bir turdagi matematik muammolarni hal qilish jarayonini tushunishga yordam beradi;

- *Mavzularning keng doirasi:* “Mathway” matematik mavzularning keng spektrini qamrab oladi, jumladan, algebra, geometriya, trigonometriya, hisob-kitoblar, statistika va chekli matematika;

- *Foydalanuvchi uchun qulay interfeys:* veb-sayt va mobil ilova matematik ifodalarni kiritish va yechimlarni ko’rish uchun qulay interfeysni ta’minlaydi;

- *Obuna opsiyalari:* “Mathway” misol va masalalarni hal qilish bo’yicha asosiy xizmatlarni bepul taqdim etsa-da, u obunaga asoslangan modelga (Mathway Plus) ham ega bo’lib, bu reklamasiz kirish, misollarni onlayn rejimda ishlash va tezroq yechimlarni olish kabi qo’shimcha funksiyalarni ta’minlaydi;



- *Ta'lim vositasi*: bunda ishni tekshirish va muammoni hal qilish bosqichlarini tushunish uchun foydali vosita bo'lishi mumkin bo'lsa-da, talabalar uchun "Mathway" dan mas'uliyat bilan foydalanish va o'rganish uchun faqat unga tayanmaslik muhim o'rin tutadi. U eng yaxshi darslar davomida o'rganish va individual amaliyotga qo'shimcha sifatida ishlatiladi.

"Mathway" matematika sohasidagi fanlarning keng doirasini qamrab olib, u quyidagi ba'zi asosiy toifalar va mavzulardan iborat:

1. Algebra;
2. Boshlang'ich algebra;
3. Trigonometriya;
4. Boshlang'ich hisob;
5. Hisob (shu jumladan hosilalar, integrallar va boshqalar);
6. Statistika;
7. Cheklangan matematika;
8. Kimyo (asosiy kimyoviy tenglamalar).

Masalaning qo'yilishi

Shulardan kelib chiqib, biz hozirda UMFT da o'qitilayotgan "Hisob" fanining "Funksiyani hosila yordamida tekshirish va grafigini yasash" mavzusi doirasida berilgan misollarni ushbu "Mathway" tizimida tekshirib ko'ramiz.

Funksiyani to'la tekshirish va grafigini yasash quyidagilarni aniqlash yordamida amalga oshiriladi:

- 1) Funksiyani aniqlanish sohasini topish.
- 2) Aniqlanish sohasining chegaraviy nuqtalaridagi xarakterini aniqlash.
- 3) Funksiyaning juft yoki toqligini va, agar imkon bo'lsa, boshqa markaz va simmetriya o'qlarini aniqlash.
- 4) Davriylikka tekshirish.
- 5) Uzilish nuqtalarini topish va ularning turini aniqlash (2-punktini to'ldiradi).
- 6) Koordinata o'qlari bilan kesishish nuqtalarini topish.
- 7) Funksiyaning ishorasi o'zgarmaydigan oraliqlarni aniqlash.
- 8) Monotonlik va ekstremumga tekshirish.
- 9) Egilish nuqtalari, qavariqlik va botiqlik oraliqlarini topish.
- 10) Asimptotalarni aniqlash.
- 11) Tekshirish natijalarini x , y , $f(x)$, $f'(x)$, $f(x)$ larga mos bo'lgan jadval ko'rinishida ifodalash (oxirgi bandeda faqat ishora aniqlanadi).
- 12) Jadvaldagi nuqtalarni tekislikda ifodalash.
- 13) Asimptotalarni yasash.
- 14) Yuqoridagi tekshirish natijalarini hisobga olgan holda tekislikdagi nuqtalarni chiziq yordamida tutashtirish.

Biz mathway.com web sayti yordamida yuqoridagi tekshirishlarni quyidagi funktsiyani tekshiramiz.

$$f(x) = 6x^{-5} + 3.$$

Natijalar

Mathway.com da ishchi paneliga yuqoridagi funktsiya kiritilib uning grafigini yaratish buyrug'i berilganda, funktsiyaning grafigidan tashqari uning vertikal va gorizontal asimptotalari kabi ma'lumotlarni ham aniqlab bera oladi.

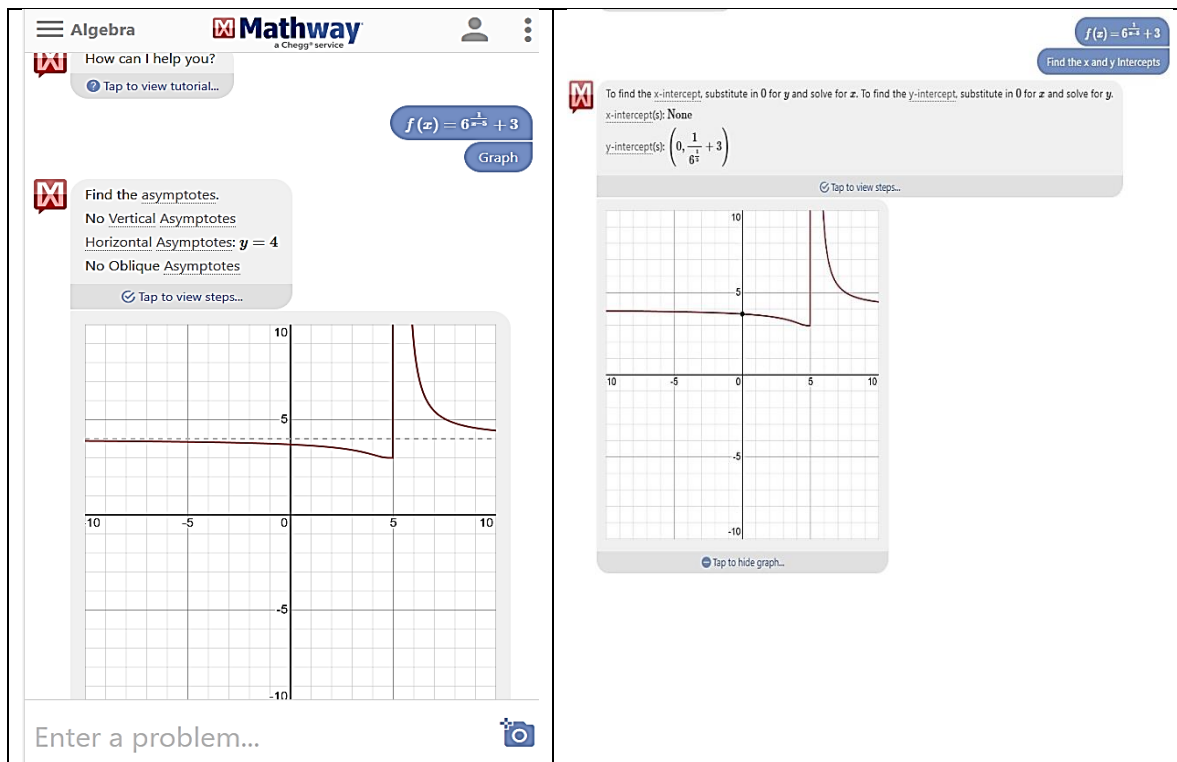

1-rasm. Mathway tizimining umumiy ko'rinishi

Tizim bizga taqdim qilgan funktsiyaning grafigidan ko'rishimi mumkunki $x = 5$ nuqta uzulish nuqtasi chunki, u bu nuqtada aniqlanmagan, sababi funktsiyaning $x = 5$ bo'lgandagi darajasidagi kasrning mahraji 0 ga teng bo'ladi.

Berilgan funktsiya $(-\infty, 5) \cup (5, \infty)$ oraliqlarda kamayuvchi funktsiya (o'suvchi oraliq mavjud emas).

Funktsiya $(0; \frac{1}{6^5} + 3)$ nuqta (taxminan $(0; 3,7)$ nuqta)da koordinataning y o'qini kesib o'tadi

Mathway.com web dasturi orqali funksiyaning asimptotasini ham aniqlashimiz mumkin. Yuqoridagi rasmda ko‘rinib turibdiki funksiya faqat 1 ta gorizonttal asimptotaga ega va u $y = 4$ nuqtani kesib o‘tadi (nuqtada joylashgan). Funksiya hech qanday ekstremum nuqtaga ega emas.

$f(x) = 6^{\frac{1}{x}} + 3$

Find the Maximum/Minimum Value

Use the derivative to find the maximum and minimum.
No Local Extrema
Tap to view steps...

2-rasm. Mathway tizimida funksiya ekstremum nuqtaga ega emas.

Xulosa

Xulosa o‘rnida shuni aytishimiz mumkinki, demak “Hisob (matematika)” fanini o‘rganishimizda “mathway” kabi axborot tizimlarining oliy ta’lim muassasasi talaba va professor-o‘qituvchilari uchun ahamiyati juda katta.

Bundan tashqari, bunday tizimlarning ommabopligi shundaki unda nafaqat talabalar balki ixtiyoriy matematika fanini o‘rganishni boshlagan yoki fanni o‘rganishda davom etayotgan o‘quvchilar uchun muhim vositalardan biridir.

Bu bizlarga Web texnologiyalar va sun’iy intellektni tushunishimiz, uni mukammal o‘rganimiz sari bilimlarimizni rivojlanishida muhim ahamiyat kasb etadi.

Bunday axborot tizimlarini o‘rganilayotgan fanlarga qo‘llanishi fanni o‘rganishimizda va bu fan haqidagi bilim va ko‘nikmalarni mustahkamlashga katta yordam beradi.

Tizimning vizual imkoniyatlari esa masalalarning haqiqiy yechimlarini aniq tasavvur qilishimizga yordam beradi.

Oxirgi hulosasi sifatida shuni ta’kidlash mumkinki, universitetda o‘qitilayotgan “Hisob (matematika)” fanini mavzularini talabalarga yoritib berishda bunday tizimlar talabalarda mazkur mavzularni tezroq o‘zlashtirish imkoniyatini berib, bu talabalar uchun ham darsni o‘tayotgan o‘qituvchi uchun ham juda qulay va zamonaviy vosita hisoblanadi.

Adabiyotlar

1. Асадов К.У., Пардабаев С.Б. Методические указания по проведению практических занятий по курсу МАТЕМАТИКА (исчисление). Ташкент UMFT, Узбекистан, 2023; 128 с.
2. Claudio Canuto, Anita Tabacco “Mathematical Analysis”, Italy, Springer, I-qism, 31-63 sahifa, 2008, II-qism, 33-73-sahifalar, Springer, 2010
3. W.W.L Chen “Introduction for Fourier Series”, London, Chapter 1-8, 300 sahifa, CRC Press, 2004, 2013.
4. W.W.L Chen “Foundamentals of Analysis”, London, Chapter 1-10, 1983, 152 sahifa, Macquarie University, 2008.
5. Soatov Y.U “Oliy matematika”. T o‘qituvchi, 1995. 1-qisim. 150-159-sahifalar. 2-qism
6. N.M.Jabborov, E.” Oliy matematika”. 1-2 qism. Qarshi, 2010, 3-51-sahifalar, Cho‘lpon.
7. Асадов К.У., Холбоев И.А. WEB технологии в организации учебного процесса на примере курса «Численные методы и программирование». Высшая Школа Научно-практический журнал № 11 / 2017, стр. 83-84. ISSN 2409-1677.
8. www.mathway.com – matematik muammolarni tushunish va hal qilish uchun zarur bo‘lgan vositalarni taqdim etadigan onlayn tizim resursi.

Management and Future Technologies

journal.umft.uz